



# REGREEN

ASID & USGBC

Residential Remodeling  
Guidelines

REGREEN Residential Remodeling Guidelines 2008

Copyright pending © 2008 by the American Society of Interior Designers and U.S. Green Building Council. All rights reserved.

None of the parties involved in the funding or creation of the REGREEN Residential Guidelines, including ASID and U.S. Green Building Council, its members, its contractors or the U.S. government, assume any liability or responsibility to the user or any third parties for the accuracy, completeness or use of or reliance on any information contained in the REGREEN Residential Guidelines, or for any injuries, losses or damages (including, without limitation, equitable relief) arising from such use or reliance.

As a condition of use, the user covenants not to sue and agrees to waive and release ASID and U.S. Green Building Council, its members, its contractors and the U.S. government from any and all claims, demands and causes of action for any injuries, losses or damages (including, without limitation, equitable relief) that the user may now or hereafter have a right to assert against such parties as a result of the use of, or reliance on, the REGREEN Residential Guidelines.

The builder (or primary project manager) is solely responsible for choosing REGREEN Residential Guidelines features that are appropriate for the home and for their proper installation. Use of these guidelines in no way constitutes a warranty as to the appropriateness of the selected REGREEN Residential Guidelines best practices or the quality of implementation.

ASID  
608 Massachusetts Ave., NE  
Washington, DC 20002-6006

U.S. Green Building Council  
1800 Massachusetts Avenue, NW, Suite 300  
Washington, DC 20036

REGREEN™ trademark pending 2008 by the American Society of Interior Designers and U.S. Green Building Council. All rights reserved.

ISBN-10: 1-932444-12-2 ISBN-13: 978-1-932444-12-4

Cover Photo: Fine Homebuilding



# REGREEN

ASID & USGBC

Residential Remodeling  
Guidelines

[www.regreenprogram.org](http://www.regreenprogram.org)



# Contents

Preface . . . . .	v
Acknowledgments . . . . .	vii
Introduction . . . . .	viii
How to Use The Guidelines . . . . .	x
Green From The Start . . . . .	xii
Kitchen . . . . .	1
Bathroom . . . . .	7
Bedroom . . . . .	13
Living & Working . . . . .	19
Finished Basement . . . . .	25
Home Performance . . . . .	31
Major Addition . . . . .	37
Gut Rehab . . . . .	43
Deep Energy Retrofit . . . . .	49
Outdoor Living . . . . .	55
Strategy Library . . . . .	61
Strategy Image Appendix . . . . .	131
Glossary . . . . .	153
Building Profile Worksheet . . . . .	163
Photography/Illustration Credits . . . . .	166





## Preface

### ASID

The American Society of Interior Designers (ASID) is a community of people—designers, industry representatives, educators, and students—committed to interior design. Through education, knowledge sharing, advocacy, community building, and outreach, the Society strives to advance the interior design profession and, in the process, to demonstrate and celebrate the power of design to positively change people’s lives. Its more than 40,000 members engage in a variety of professional programs and activities through a network of 48 chapters throughout the United States and Canada.

ASID endorses the following principles of environmental stewardship:

- **Advocacy for Safe Products and Services:** Interior designers should advocate with their clients and employers the development of buildings, spaces, and products that are environmentally benign, produced in a socially just manner and safe for all living things.
- **Protection of the Biosphere:** Interior designers should eliminate the use of any product or process that is known to pollute air, water, or earth.
- **Sustainable Use of Natural Resources:** Interior designers should make use of renewable natural resources, including the protection of vegetation, wildlife habitats, open spaces, and wilderness.
- **Waste reduction:** Interior designers should minimize waste through the reduction, reuse, or recycling of products and encourage the development and use of reclaimed, salvaged, and recycled products.
- **Wise Use of energy:** Interior designers should reduce energy use, adopt energy conserving strategies, and choose renewable energy sources.
- **Reduction of risk:** Interior designers should eliminate the environmental risk to the health of the end users of their designs.

ASID believes that interior designers should endeavor to, whenever feasible, practice sustainable design. Interior designers should meet present-day needs without compromising the ability to meet the needs of future generations.

Of the Society’s 20,000 practicing interior designers, 6,500 practice primarily in the commercial field with 4,000 practicing primarily as residential designers. The remaining 9,500 work in both commercial and residential design. Professional members of ASID must pass rigorous acceptance standards: they must have a combination of accredited design education and/or full-time work experience and pass a two-day accreditation examination administered by the National Council for Interior Design Qualification (NCIDQ).

ASID Industry Partners include nearly 3,000 member firms with more than 8,000 individual representatives, uniting the professional designer with manufacturers of design-related products and services.

The Society’s membership also includes more than 12,000 students of interior design. ASID has more than 300 student chapters at colleges, universities and design schools with 2-year and 4-year programs throughout the U.S. and a “virtual” chapter through Rhodex International.

### Contact the American Society of Interior Designers

ASID  
608 Massachusetts Ave., NE  
Washington, DC 20002-6006

tel: (202) 546-3480  
fax: (202) 546-3240  
e-mail: [asid@asid.org](mailto:asid@asid.org)

## USGBC

The built environment has a profound impact on our natural environment, economy, health, and productivity. Breakthroughs in building science, technology and operations are now available to designers, builders, operators, and owners who want to build green and maximize both economic and environmental performance.

The U.S. Green Building Council (USGBC) is coordinating the establishment and evolution of a national consensus effort to provide the industry with the tools necessary to design, build, and operate buildings that deliver high performance inside and out. Council members work together to develop industry standards, design, and construction practices as well as guidelines, operating practices and guidelines, policy positions, and educational tools that support the adoption of sustainable design and building practices. Members also forge strategic alliances with industry and research organizations, federal government agencies, and state and local governments to transform the built environment. As the leading organization that represents the entire building industry on environmental building matters, USGBC's unique perspective and collective power enable our members to effect change in the way buildings are designed, built, operated, and maintained.

The Council's greatest strength is the diversity of its membership. USGBC is a balanced, consensus nonprofit organization representing the entire building industry, comprising more than 12,000 companies and organizations. Since its inception in 1993, USGBC has played a vital role in providing a leadership forum and a unique, integrating force for the building industry. USGBC programs are distinguished by several features:

- Committee-based

The heart of this effective coalition is the committee structure, in which volunteer members design strategies that are implemented by staff and expert consultants. USGBC committees provide a forum for members to resolve differences, build alliances, and forge cooperative solutions for influencing change in all sectors of the building industry.

- Member-driven

Membership is open and balanced and provides a comprehensive platform for carrying out important programs and activities. USGBC targets the issues identified by its members as the highest priority. In annual reviews of achievements, USGBC sets policy, revises strategies, and devises work plans based on members' needs.

- Consensus-focused

USGBC members work together to promote green buildings and, in doing so, help foster greater economic vitality and environmental health at lower costs. The various industry segments bridge ideological gaps to develop balanced policies that benefit the entire industry.

## Contact the U.S. Green Building Council

USGBC  
1800 Massachusetts Ave., NW  
Suite 300  
Washington, DC 20036

tel: (202) 828-7422  
fax: (202) 828-5110  
e-mail: [REGREENprogram@usgbc.org](mailto:REGREENprogram@usgbc.org)

## Acknowledgments

The REGREEN Residential Guidelines have been made possible only through the efforts of many dedicated volunteers, staff members, and others in the ASID and USGBC community.

The scope of the REGREEN guidelines emerged from conversations occurring among a variety of residential building experts convened at the Pocantico Conference Center of the Rockefeller Brothers Fund, April 27–29, 2007. The REGREEN guidelines were developed by a technical committee comprised of both ASID and USGBC members and invited experts. It reflects the views of the authors and not necessarily those of other conference participants or of the Rockefeller Brothers Fund, its trustees, or its staff.

The REGREEN Residential Guidelines drafting was managed and implemented by ASID and USGBC staff and included review and suggestions by many technical advisors. We extend our deepest gratitude to all of our Steering Committee Members who participated in the development of the REGREEN Residential Guidelines, for their tireless volunteer efforts and constant support of ASID and USGBC's shared vision for this project. They are:

Penny Bonda, FASID; Environmental Communications  
Victoria Schomer, ASID; Green Built Environments  
Linda Sorrento, ASID; USGBC  
Peter Templeton, USGBC  
Michael Alin, Hon. FASID  
Thom Banks, Hon. FASID

Special thanks to the BuildingGreen and Green Built Environments team for their substantial and invaluable contributions to the creation of the REGREEN Residential Guidelines:

Peter Yost                      Alex Wilson  
Amie Walter                    Jennifer Atlee  
Rachel Navaro                Victoria Schomer  
Julia Jandrisits

Special thanks to case study and content contributors.

Professionals:

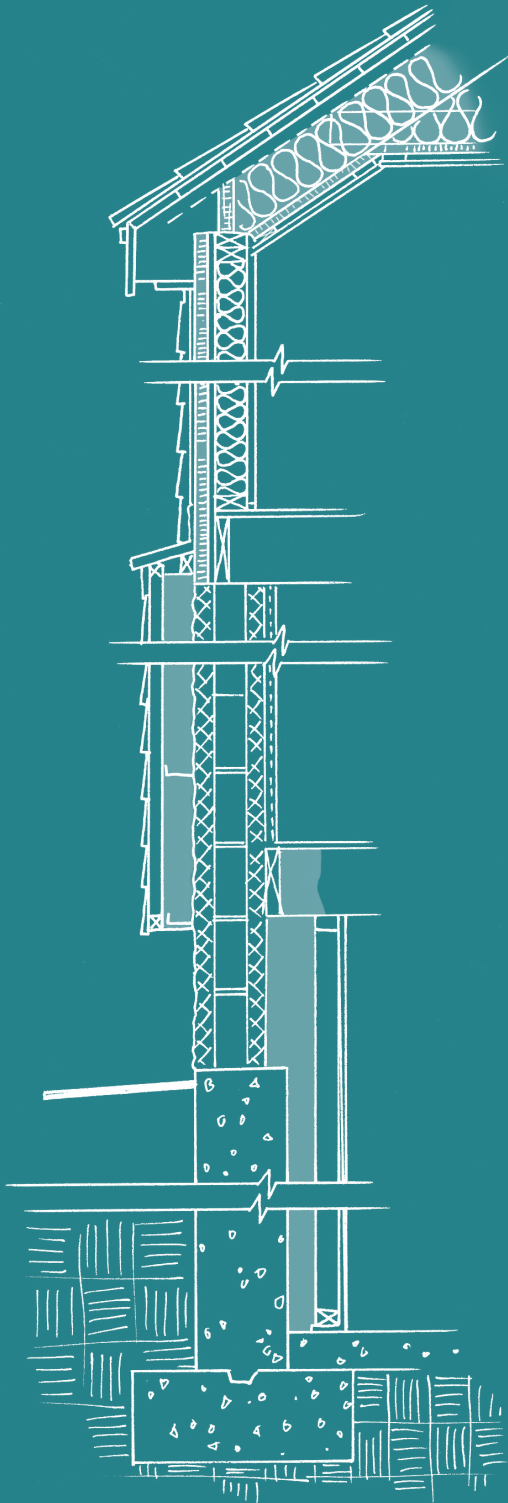
Mark Bergmeier, Northeast Iowa  
Community Action Corporation  
Mary Cordaro and Scott Jones  
Lydia Corser, Eco Interiors  
Debra Lynn Dadd and Larry Redalia  
Eric Doub, EcoFutures Building, Inc.  
Asa Foss, Sentech Inc.  
Matt Golden, Sustainable Spaces  
Jay Hall, Building Knowledge Inc.  
Matt Hoots, The Hoots Group  
Mike Keyes, Corporation For Ohio Appalachian  
Development (CAOD)  
Emily Mitchell, Enterprise Community Partners  
Jim Perry, NEICAC  
Thor Peterson, Cascadia Region  
Green Building Council  
Robert Politzer, GreenStreet Construction Inc.  
Carl Seville, Seville Consulting

Annette Stelmack, Allied Member ASID,  
Inspirit-LLC  
Dan Taddei, National Association of the  
Remodeling Industry (NARI)  
Linda Wigington, Affordable Comfort, Inc.  
Dawn Zuber, Studio Z

Homeowners:

Laura Alderman and Gary Garcia  
Debra Lynn Dadd and Larry Redalia  
Mary Cordaro and Scott Jones  
Pam and Tim Sowerby  
Carol Anne and Richard Hendrix  
Kathy and Mike Manus  
Steve and Linda Norton  
Alicia and David Basche  
John and Vicky Graham  
Grace Riggan and Joshua Bowles

# Introduction



## Background

Green remodeling is the design and construction of projects that reduce environmental impacts of remodeling, including energy, water, and materials consumption; waste generation; and harmful emissions, both indoors and out.

While the principles that govern green residential remodeling are shared with all other design and construction projects, there are more than a few aspects of green remodeling that make it unique, particularly with respect to green homes:

- **Range of projects** – Residential remodeling covers everything from painting a room to refitting a kitchen to gutting a whole house down to the framing and then rebuilding.
- **Existing conditions** – In new home construction we generally have just the site to consider, but in residential remodeling there are existing conditions that range from room configuration to hazards such as mold, lead, and asbestos.
- **Custom nature of the work** – Whether in design or construction, just about every residential remodeling project is custom with very little opportunity for the sorts of economies of scale that occur in production building.
- **Building professional/client relationship** – Remodeling professionals almost always have a client; “spec” remodeling projects are rare. This much closer relationship to homeowners requires skills and perspectives not generally required for new construction projects.
- **Occupants** – Remodeling professionals must plan and often conduct their work based on the health, safety and schedules of real people. Even if the work requires that the home be vacated, the timing and duration of such a period must be very carefully orchestrated.
- **Sequenced or staged projects** – Many residential remodeling projects are phased or sequenced projects (“we want to do the bathroom and then the kitchen”), and this can make for challenging orders of operation in both design and construction, often requiring innovation and improvisation by remodeling professionals.
- **An added level of integration** – A cornerstone of all types of green building is systems integration, and residential remodeling adds a new dimension to this integration: integrating the “old” or existing with the new.

These unique aspects of residential remodeling mean that a separate program, resources, and approach are needed for green residential remodeling. Hence, a program focused around a best practices guide, rather than a rating program, makes sense.

This program and best practices guide to green residential remodeling is conceived of and implemented through a partnership between the American Society of Interior Designers (ASID) Foundation and the United States Green Building Council (USGBC).

## A Focus on the Whole-House, Systems-Thinking Approach

It is easy and tempting to boil down green building to simply product selections and glide over, or even ignore, the challenges of green building as a process. The REGREEN Program and the REGREEN Guidelines are about products and process, about synergies and unintended consequences. In green building, it is rarely a single product or building component or a collection of attributes that result in a building being labeled “green.” Green building is almost always about how systems or the whole building work together to reduce environmental impacts. In the REGREEN Guidelines, systems-thinking and integration is represented by the cross-listing of strategies by project and environmental category, as well as by the “potential issues” section of each strategy write-up. In the electronic version of the REGREEN Guidelines, an extensive system of electronic links brings about the systems integration and “ankle bone connected to the leg bone” nature of green residential remodeling.

## A Focus on Professional Integration

Let’s be frank: getting interior designers, architects, engineers, builders, and trade contractors all on the same page is not easy and is not an everyday occurrence. Yet that is exactly what the REGREEN Program and these Guidelines do. By having content, resources and case studies that tie together best-practice design and construction, all building professionals are included in the Guideline content and all are encouraged to use it. Green residential remodeling does not just suggest professional integration at all levels and across all disciplines; it requires it.

And while the target audience of the REGREEN Guidelines is building professionals—interior designers, architects, remodelers, and the trades—it should come as no surprise that savvy homeowners and do-it-yourselfers have already shown strong interest in this resource. THEY want green remodeling integration too!

## Green Versus “Good” Design

One of the challenges in developing resources for green building is deciding how to address what constitutes green design and construction, vs. what constitutes good

design and construction. What is the relationship between the two? The REGREEN Program and Guidelines work from this perspective: you can have a quality project that is not a green project, but you cannot have a green project that is not also a quality project. Good design and construction are the foundation of green design and construction. For example, you can’t have just efficient lighting; it must also be effective lighting. Similarly, beauty is an integral part of green design and construction; it is the beauty of a building or project that is the starting point for durability, one of the most important attributes in green building.

## Dealing With Climate and Site

A very significant aspect of building green is designing and constructing with respect to the climate and site. The REGREEN Guidelines handle this aspect of green residential remodeling in three ways:

- **Strategies:** Certain strategies suggest varying degrees of implementation, depending on climate—for example, additional insulation or better-performance windows in colder climates.
- **References/Resources:** Many of the sources of qualified additional information yield climate- and site-specific guidance.
- **Case Studies:** While by no means a comprehensive approach to climate and site, the case studies provide examples of how green residential remodeling can be expressed in types of projects in particular climates and on particular sites.

## What the REGREEN Guidelines Are, and What They Are Not

The REGREEN Guidelines:

- **Are comprehensive, but not stand-alone.** The Guidelines depend heavily on vetted links to additional information on specific topics. Given the nature of green building and the depth and breadth of residential remodeling in particular, the Guidelines have to depend—as do you, the user—on connecting with the best resources for more extensive coverage of techniques, strategies, and materials.
- **Are PDF based resources, for now.** It was clear to the developers of the REGREEN Guidelines that electronic resources would offer some significant advantages in covering green residential remodeling. Such a resource would allow for different avenues of initial approach to green residential remodeling, making systems integration and systems thinking natural and easy—and would accommodate evolution and constant improvement to the REGREEN program. But while the goal is to move

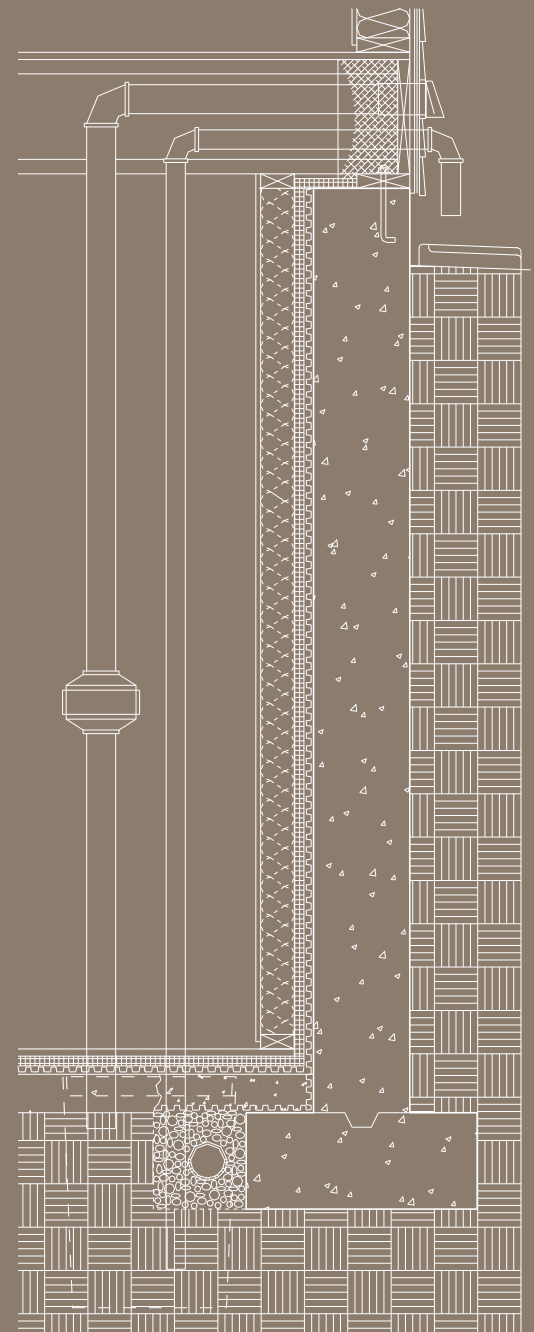


the REGREEN Guidelines to electronic resources with learning programs to support the use of the guidelines, today it is only available in PDF form. Refer to [www.regreenprogram.org](http://www.regreenprogram.org) for new program updates.

- **Is project-based, not project-specific.** These Guidelines can provide guidance on green remodeling for a variety of projects (ten to date), but it cannot give you definitive guidance on your project. If you are unsure how a particular method, material, or design feature fits into your project, you will need to use the principles of green design and construction in these guidelines to adapt and apply appropriately to your unique circumstances and project.
- **Is primarily single-attribute, not LCA-based product selection guidance.** We simply do not have comprehensive, multi-attribute tools today to compare and weigh recycled-content and recyclability, locally-sourced and low-emitting materials, manufacturing and maintenance environmental impacts. The term “environmentally preferable” in these Guidelines uses different proxies for reduced environmental impact, but does not use a full life cycle analysis to fully evaluate products. You will need to accomplish your own balance of various product attributes in weighing the value of one production selection strategy versus another. Take a look at the the Product Considerations resources on [www.regreenprogram.org](http://www.regreenprogram.org) to augment the product strategies in the REGREEN Guidelines Strategy Library.
- **Is not a rating system.** The developers of these Guidelines have dovetailed as much as possible with the content and resources of the LEED for Homes Rating System, (refer to [www.usgbc.org](http://www.usgbc.org)), but not to the extent that any sort of rating or certification can be applied to green residential remodeling projects completed using these Guidelines. Where applicable, we have referenced standards and certifications used by the LEED for Homes Rating System, including but not limited to:
  - Energy ratings – HERS, EPA Energy Star
  - Water efficiency criteria – EPA WaterSense specifications
  - Material selections – Forest Stewardship Council (FSC) wood certification, GREENGUARD Children and Schools, Green Seal
  - Indoor air quality – ASHRAE 62.2

# How to Use the Guidelines

The Guidelines are organized primarily by project type. The developers felt that the single best way to engage the remodeling professional and informed, dedicated layperson was to focus on the ten most common remodeling projects.



## Here is the Primary Way to Use the Guidelines:

### 1. Start Green

Take a look at the following section, “Green From the Start,” and use this as a way to approach every green remodeling project. Don’t be shy about using the glossary, even if it is just to make sure that the REGREEN authors are using a term the same way that you do.

### 2. Pick a Project Type

Each of the ten project types has three major elements:

**A) Integrated Pre-Design Issues:** Many of the most significant opportunities for reducing the environmental impact of a residential remodeling project, or any building project for that matter, lie in the decisions made at the very start of a project. The Integrated Pre-Design Issues lay out key questions—by project type—that may challenge some project assumptions of either the building professional or the client.

**B) Project Scope and Strategy Lists:** For each project, the most important green remodeling strategies that apply to the project are listed around an illustration of such a project. Space limitations dictate that some relevant strategies may not be individually expressed in a given project type; the user may be directed to another project type for a list of additional strategies. The strategy lists are organized by building system or sequence—an order that represents how a remodeling professional (or informed client) typically thinks about a project.

**C) Project Case Study:** Many of us in the building profession understand and internalize principles and practices best when they are expressed through an actual project. For each of the ten project types, a representative green remodeling project is captured through photos; comments from the designer, builder and client; and discussion of key elements of design and construction.

But be careful how much you read into each of the case studies. They often capture many, but not all of the relevant strategies. They do not necessarily represent the final word or “platinum” perspective; they are guidance, not guided. You are likely to get as much from the “Lessons Learned” as you are the “Project Features” section of each case study. The case studies were selected based on a long list of attributes; they can only be improved by having lots of company as the REGREEN program grows and evolves.

### 3. Follow Individual Strategies into the Strategy Library

There are nearly 200 write-ups of green remodeling strategies in the Strategy Library. The Strategy Library is organized at the top level by environmental topic, so that while you are following up on one strategy, say on water efficiency, you will see other water efficiency strategies that may be relevant to this or another remodeling project you are involved with. The strategy write-ups include:

**A) A general description of the strategy:** What it entails and what it means in terms of reduced environmental impact.

**B) Potential Issues:** This section may cover positive synergies that can be accomplished by considering other strategies along with the one at hand, possible unintended consequences of the strategy to be aware of, and issues related to cost, feasibility, or other implications of the strategy.

**C) Related Strategies:** Each strategy links to other strategies that are related in terms of synergies, unintended consequences, or likely partner strategies.

**D) References/Resources:** It is not possible in such short write-ups to provide a lot of detail on the strategies in these Guidelines. You are directed to some of the best resources for additional guidance on each strategy.

**E) Details and Images:** Photographs and architectural details further illustrate particular strategies or make critical detailing clear. The title of the detail or image links to a larger view in the image appendix. Where many images refer to a single strategy, all titles are listed, but only one thumbnail is shown.



Users of the Guidelines can, of course, simply browse the Strategy Library using its table of contents. Many experienced green remodeling professionals will use the Guidelines in this way as a sort of brainstorming checklist to remind them of opportunities to consider.

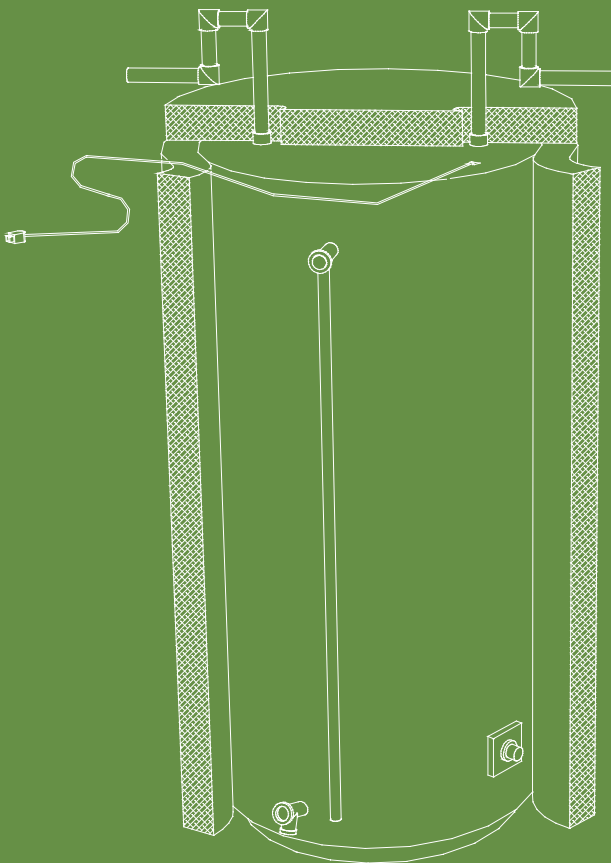
That’s it. We hope that you find your use of these Guidelines as informative and pleasurable as the developers did in creating it.

# Green From the Start

The start of every remodeling project—whether a single room renovation or whole-house gut-rehab—takes comprehensive project planning with the major players involved in the remodeling process.

No less important for the green remodeling project, comprehensive green project planning follows these steps:

- Client Interview
- Building Assessment
- Systems-Integrated Team Building
- Cost-Benefit Analysis
- Code and Zoning Issues Management



## Client Interview

It is important to begin every project with a “guided discovery” process with the client, asking both open-ended and pointed questions to determine their reasons for renovating in the first place. This process gives the client opportunities to express desires, issues, and concerns, and to develop goals, ensuing strategies, and budgets that are aligned with these desires, needs, and expectations. This important up-front process also allows for the design and building professionals to identify issues of which the owners may not be aware.

Some representative questions for this client interview include:

- What precipitated the desire for a remodel?
- What do they like about the house?
- What things about the house no longer work for their needs or lifestyle?
- What results do they expect from their renovation?
- Is their house moldy, dusty, dry, or damp?
- How long are they planning to live in the house?
- What compromises have they made due to existing problematic conditions?
- Are health issues driving their remodeling project?
- What are their attitudes towards the operations, maintenance, and cleaning of their home?
- Are they happy with the quality of finishes, and furnishings, and what are they looking to keep and upgrade?
- Is increased water efficiency a goal?
- Does the house provide them with the desired amount of daylight and sunshine?
- Do their utility bills seem very high?
- Are there hot or cold spots in their house?
- Do they have to wait a long time for hot water to reach certain fixtures?
- What thermostat setting do they use in the summer and winter?

This guided discovery process provides another opportunity—setting expectations and identifying cause-and-effect outcomes. Energy retrofits can improve both energy performance and thermal comfort, but sometimes increased comfort comes at the price of reduced overall energy improvement. If exhaust fans are required to ensure a healthy, comfortable interior, for example, homeowners need to be aware of the energy costs of those fans. It’s important that the clients know just what they must do to maximize the benefit of the green investment they will make in the project.

## Building Assessment

The foundation of green remodeling is performance-based systems integration: understanding and then capturing how the structure, finish, furnishings, and mechanical systems work together to make a home safe, healthy, efficient, and durable over time. The six key elements to assess and honor or improve are:

- Building/Site Interfaces
- Home Performance
- Mechanical Systems
- Interior Spaces
- Materials
- Hazards

**Building/Site Interfaces** – The way that sunlight, water, and wind move across or off of the home’s shell can augment or challenge home performance and levels of comfort. Surface water and groundwater movement can be assessed for proper drainage; trees and adjacent structures can be assessed for desired shading or solar access potential and natural ventilation strategies. Site conditions should also be placed in the larger context of climate, with recommendations for both building envelope and HVAC solutions honoring both opportunities and constraints that climate conditions bring to the project.

**Home Performance** – Assessment of the building envelope and mechanical systems are the two major elements of a home performance audit.

The building envelope components that manage water, air, and heat must be continuous and complete. Many existing homes have gaps or a complete lack of one or more of these barrier systems.

A combination of visual inspections and testing (blower door, infrared technology, moisture meters) can help identify deficiencies in the water, air, and thermal barrier systems, providing you with the information you need to repair, relocate, or create continuous protection systems.

We try to keep our building envelopes from getting wet and we try to help them dry if—or more likely when—they do get wet. Vapor profiles of building assemblies are simply assessments of the water/air/vapor permeability of each and all of a wall’s or roof’s components and making sure that these properties permit or encourage drying of the assemblies to the outside, inside, or both. It’s often not necessary for this assessment to be quantitative; knowing the relative permeability of assembly components is often enough to gauge drying potential.

There are building assessment tools that green remodeling professionals can use. The LEED for Homes Durability Evaluation Form (from Credit 2 in the Innovation and Design Process section) is one example and the Building Profile Worksheet listed in this Guide’s appendices is another.

**Mechanical Systems** – These include heating, air conditioning, fresh air ventilation, plumbing, and electrical wiring and equipment. Forced-air HVAC systems can be tested using a duct blaster to identify duct defects. Furnaces, boilers, and gas water heaters can be inspected and tested for combustion safety. Hot water pipes can be identified and tested to determine how long it takes for water to reach fixtures. Finally, wiring, switching, lighting, and other equipment can be assessed for potential improvements such as lamp or fixture replacement.

**Interior Space, Furnishings, and Equipment** – In tandem with the assessment of the building structure itself is the determination of how well the layout of the existing spaces within the home is working. Current use of space, re-organization of space, and ease of navigation through the home are all a part of this assessment. The placement of furniture and equipment establish patterns of movement that should support the activities, health and safety of the home occupants, and not interfere with goals such as improved efficiency, comfort, air quality, and noise acoustics.

Every existing home also comes with a substantial inventory of furniture, equipment, and hundreds of furnishing and accessory items—flooring, lighting, window treatments, and artwork to name a few. Assessment and inventory of these existing goods must be done to ensure that the new proposed floor plan maximizes the space and traffic flow relationships throughout the house and balances replacement and refurbishing.

**Materials** – There are two sides to this assessment: evaluating materials that should NOT become waste because of their reuse potential and evaluating materials that are not only waste, but hazards.

Selective or complete dismantling of a home are demolition methods called “deconstruction,” which uses skilled labor as an alternative to the wrecking ball. It can preserve for reuse everything from floor joists to the kitchen sink, from the front door to the light fixtures. Every brick, stick of lumber, or salvaged architectural detail removed from the waste stream saves valuable landfill space, conserves production energy, and can potentially add beauty and historical value to the renovation of the home.



**Hazards** – These can be mold, water leaks, poor indoor air quality, lead-based paint, radon, asbestos, and structural defects. Some can be assessed by straight visual inspection; others require testing. All are important to the health of the building, the occupants, and the remodeling project.

## Integrated Team Building

One of the most important aspects of green remodeling is assembling a project team that understands the importance of systems integration and how their jobs might be a little different because of this approach.

For example, designers must work with the builder to integrate mechanical systems with the structure, keeping ducts and equipment within conditioned space. The project manager (head carpenter) may need to work out some sequencing details with the insulation contractor to ensure that the air and thermal barriers are complete and continuous, especially at challenging locations, such as behind the tub on an outside wall. The painting contractor needs to understand that substituting a different quality of caulk or paint is not acceptable because of the impact on indoor air quality or the moisture performance of the exterior wall assembly. This type of coordination or systems integration almost always requires three things:

- A team leader who keeps the clients' goals and big picture in mind and who, on his/her own or working with the client, assembles a project team capable of systems-thinking.
- High-quality floor plans, drawings, specifications, and contractor scopes that fully support the project goals.
- Training, whether it is obtained through a trade association's green certification process or simply by having team members work their way through the REGREEN Guidelines.

Green remodeling expertise, including systems integration, can reside in a single person or be spread throughout the team. Not every project team will require a green remodeling consultant, but the benefits of including such expertise may quickly exceed the costs.

## Cost-Benefit Analysis

Cost-benefit analysis is an important part of the “guided discovery” process that takes place with the client. Green remodeling professionals have a special opportunity to show how systems integration can actually improve cost-benefit outcomes and provide greater overall value, particularly in the long term. Examples include:

- Deeper improvements to the thermal performance of the building envelope can result in downsizing or even eliminating HVAC components, generating a breakeven or even an improved cost-benefit ratio on these elements of the remodel.
- The building and interiors assessment and guided discovery in the client interview shifts the remodeling project from a major addition to (primarily) a reconfiguration of existing space.
- The building and interiors assessment and guided discovery shift the project from an inappropriate gut rehab on a failing structure, to the overall more valuable deconstruction and complete re-building of the home.

Green remodeling clients are very likely already attuned to a discussion of cost-benefit that includes an expanded definition of value. But using the systems-integration approach to augment the discussion of cost-benefit can move the discussion from, “I have heard that building green costs a lot more” to, “It’s great that building green delivers so much more value.”

## Codes and Zoning Issues Management

Certain green building features and lifestyle choices can be limited or restricted by municipal codes or neighborhood covenants. Some neighborhoods forbid clotheslines as an undesirable look, for example, preventing homeowners from implementing one of the simplest ways to save energy. Approval to install solar panels may be difficult in some areas, particularly historic districts. While the building code may allow advanced framing techniques, the local building inspector may feel otherwise. Green remodeling professionals must be proactive during the planning phase of a project and not reactive during the construction phase when features of the project involve code and zoning issues.



The benefits of using the Green From The Start approach in large remodeling projects are probably pretty clear at this point. What many professionals may fail to realize is that every remodeling project will benefit from this approach, and not doing so can be risky in even the smallest projects. Consider these examples:

- **Interior Finishes:** What a designer specifies can have an effect on the performance of the building assembly, the indoor air quality, and health of the family. For example, if a designer specifies an impermeable wall covering in a hot-humid climate, moisture condensing on the back of the wall covering could result in mold growth on the paper facings of the gypsum board and even rot if the wall is a wood-framed assembly.



- **Window replacement:** As the existing window unit is pulled from the wall, it is discovered that the wall has no building paper or housewrap; there will be no way to weatherlap the flashing of the new window unit to the old assembly. If a building assessment had been accomplished during comprehensive planning, the client and remodeling professional may have worked out a more satisfactory result, such as combining the window replacement with some level of re-cladding.

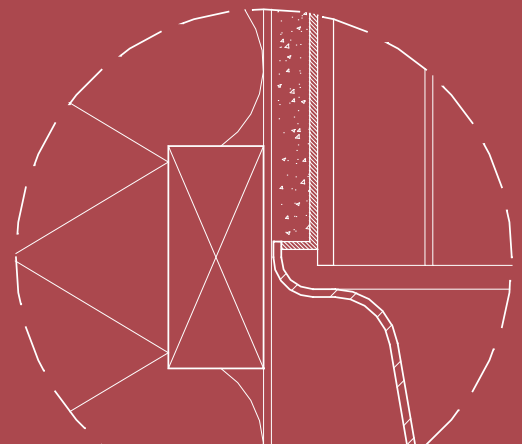


Comprehensive project planning is critical to green remodeling and interior design; it can mean a green start that leads to a green finish.

# Projects

The ten project types in the next section of this guide contain project-specific planning issues. Before moving on to the ten green remodeling projects in the Guidelines, keep these things in mind:

- **Green your projects and your business in steps.** Make every project better than the last, but don't try to do everything at once. It can be like trying to drink from a fire hose—you will drown before you slake your thirst.
- **Get professional assistance when you need it.** You may need quite a bit of help when you are starting, and less and less as you gain experience. Sources for this guidance include local green building and remodeling programs, non-profit, energy efficiency organizations, independent consultants, and experienced green remodelers and design professionals who can serve as mentors.
- **Training is critical.** Attend green building and remodeling classes before you start your first project and attend classes and conferences whenever you can. And don't forget to train your staff, your trade contractors, and even your vendors to assure that you get the consistently high performance needed to make your projects green.



# Kitchen Remodel



Today's kitchens are often the most active and multi-purpose rooms in the home. This can mean that the kitchen provides the most opportunities for "greening" the home. From lighting and appliances to plumbing fixtures and interior finishes, the kitchen is packed with ways to optimize form and function while minimizing environmental impact. For design professionals, the greatest challenge and opportunity of the "new" kitchen can be creating a design that most effectively addresses all of the kitchen's activities without doubling its size. Green kitchens don't have to be sized like a ship's galley, nor do they have to accommodate table tennis.

# Integrated Pre-Design Issues

## Function

### What does the client want and what does the client need?

The main way that environmental impact is expressed in the functionality of a kitchen is efficient use of space. The primary functions of a kitchen are work space (both food prep and paperwork), food storage (dry good and refrigerated), entertaining (the kitchen is increasingly a place where visitors congregate), and dining. Evaluation of kitchen design without a full understanding of just how the client currently uses both the kitchen and related or adjacent spaces and which of the functions the client might want to add to the new kitchen space are critical to the efficient use of space within the new kitchen and the home at large.

## Existing Conditions

### What functional or performance problems exist in the kitchen space that could be addressed at the design level, early in the project?

A project assessment should include examination of the following performance issues, in addition to user functionality issues:

- Water leaks—building envelope (outside) and plumbing (inside)
- Air leakage
- Environmental hazards: lead, asbestos, radon, interior humidity, mold, CO
- Thermal comfort
- Acoustical comfort
- Structural deficiencies
- Ventilation and exhaust and electrical hazards

## Scope

### What aspects of this project that are not currently under consideration perhaps should be given issues of access and timing of future work?

For example, a project scope does not include the insulation and air sealing of the opaque areas of the building envelope (walls, roof, foundation), but individual project conditions such as type of exterior cladding, its service life, and climate could influence how important improving the envelope's thermal performance is as part of the kitchen remodel. A green remodeler or interior designer integrates current and future projects in deliberations on the scope of the project with their client.

Conversely, it is easy for a kitchen redesign to result in “pulling out all the stops” to “maximize resale.” A green remodeler or designer needs to help the client maintain a focus on their needs and wants, not what market analysis tells them about what other people want.

## Size

### Can the kitchen remodel be accomplished with reconfiguration of existing kitchen space, does it require expansion of the kitchen into adjacent interior space, or will the kitchen remodel involve additional new space that expands the building envelope?

Satisfying certain “kitchen” functions (for example, dining and storage not related to food or food prep) may mean less overall renovation or avoiding an addition without loss in kitchen functionality.

There is often temptation to make the kitchen space bigger and to add more “bells and whistles”—a second dishwasher, a larger refrigerator, a wine chiller, etc. The importance of such features should be carefully weighed because the space requirements and energy costs are significant. Even more difficult may be decisions about storage—including countertop space for everyday or occasional-use appliances and concealed storage for small appliances and dry goods.

## Layout/Space Planning

### How will the kitchen space planning strike a balance between utility, aesthetics, and resource efficiency (especially energy and water use)?

Comprehensive space planning converts the needs expressed by the client into the action-plan for the whole team. While tradespeople may mean different things by the term ‘layout,’ the whole team needs to be involved in development of floor plans, elevations, and supporting documentation to ensure that the design is optimized across disciplines. Ensuring the health, safety, and enjoyment of occupants in the space, while minimizing environmental impact, requires special attention to:

- Glazing, both in terms of location and total square footage – Windows and skylights can provide views and a psychological connection with nature, natural daylighting, passive solar heat gain, and ventilation. But glazing often increases a room's energy load and involves penetrations in the building envelope that must be properly water-managed. The tendency, especially in kitchens, is to “overglaze” rather than strategically placing or selecting the type of glazing for optimal energy performance, views, and overall indoor environmental quality.
- Plumbing layout – Long runs for hot water result in significant energy and water inefficiencies as well as the inconvenience of long wait-times for hot water. Layouts that place plumbing in exterior walls result in increased heating and cooling loads, as well as potential indoor air quality problems through moisture intrusion, so should be avoided.
- Space conditioning layout – Keep supply registers or radiant/convective elements away from refrigerators.
- Lighting design – the location and type of electric lighting can improve kitchen functionality, appearance, and energy performance. Provide an optimal mix of task and ambient lighting. Avoid layouts and lighting designs that force recessed lights into the building envelope.
- Appliance location – Keep heating appliances—stoves, ovens, and dishwashers—away from refrigerating units. Provide an adequate air space around these appliances.
- Kitchen exhaust location – Ensure that kitchen exhaust fans will be able to readily exhaust to the outside.
- Universal design – Universal design and design for aging in place make it so occupants will need to do less remodeling later, eliminating the associated material use and waste.





## Project Scope

### Includes:

- Finishes – trim, flooring, countertops, paint
- Furnishings – cabinets, chairs
- Appliances – dishwasher, refrigerator, range (oven/cooktop), microwave
- Windows
- Fixtures and plumbing

### Does not include:

- New space or exterior recladding – See Major Addition
- Building envelope and framing – See Home Performance, Major Addition, Gut Rehab, Deep Energy Retrofit
- New heating, cooling or water heating – See Deep Energy Retrofit, Gut Rehab
- Renewable energy – See Deep Energy Retrofit

## Strategies by Building System

### General Design and Construction Strategies

- Ensure durability IDP1
- Manage noise IDP4
- Design with air quality in mind IDP5
- Design for a sustainable lifestyle IDP6
- Employ universal design IDP7
- Design for storage IDP10
- Provide a pantry IDP11
- Design a practical and useable kitchen recycling system IDP12
- Manage construction and demolition waste MR107
- Control the spread of pollutants IEQ158
- Install track-off mats at exterior doors IEQ161

### Building Envelope

- Upgrade or replace existing windows and doors EA56, EA57, EA59
- Isolate attached garages IEQ165
- Use FSC-certified wood MR118

### Plumbing

- Reconfigure plumbing to distribute domestic hot water efficiently EA77
- Install low water-use kitchen faucet WE41
- Install on-demand hot water recirculation system EA78
- Install under-sink water filtration system IEQ175
- Include a plumbing access panel MR123



### HVAC

- Install effective kitchen ventilation **IEQ166**
- Provide appropriate venting of all combustion-based heating and water heating equipment **IEQ168**
- Make sure ducting is clean **EA71**

### Lighting and Electrical

- Provide daylighting **EA83**
- Provide appropriate mix of color correct ambient and task lighting **EA84**
- Install energy-efficient electric lighting **EA85**
- Provide shading of skylights as needed **EA61**

### Appliances

- Install an energy-efficient refrigerator **EA93**
- Choose an energy-efficient dishwasher **EA94**
- Install energy-efficient cooking appliances **EA95**
- Consider the energy toll of small appliances **EA96**
- Manage phantom loads **EA98**

### Wall and Ceiling

- Install environmentally preferable interior sheathing **MR126**
- Use non-paper-faced gypsum board in moist areas **IEQ183**
- Limit use of wallcoverings in high moisture areas **IEQ184**
- Use low- or zero-VOC interior paints and finishes **IEQ185**
- Use appropriate sheens for paints and finishes **MR130**
- Use low- or zero-VOC construction adhesives, caulking, and sealants **IEQ187**
- Consider tile and tile trim pieces with recycled content **MR132**

### Floors and Flooring Products

- Consider reuse of existing flooring and subflooring **MR133**
- Refinish wood floors using environmentally preferable processes and products **MR137**
- Choose hard-surface flooring **IEQ180**
- Consider flooring made from certified or reclaimed wood **MR135**
- Consider flooring made from natural or rapidly renewable materials **MR136**
- Avoid carpeting in high moisture areas or where spills could occur **IEQ179**

### Furniture and Fittings

- Choose furniture and fittings that will not absorb moisture **IEQ188**
- Select compact furniture that incorporates storage **MR146**
- Consider reusing clean existing cabinetry or buying salvaged **MR140**
- Select cabinets made from greener materials **MR148**
- Evaluate use of cabinetry and furniture made from particleboard or MDF **MR145**
- Install environmentally preferable countertops **MR149**
- Select materials that are easy to clean **MR156**

### Use

- Set water temperature no higher than necessary **EA82**
- Use environmentally preferable cleaning materials and strategies **IEQ196**
- Properly maintain equipment **EA90**
- Install CO and smoke alarms **IEQ164**
- Educate homeowner for green living **EA103, EA104, EA105**





# case study

**Location:** Santa Cruz, California  
**Homeowners:** Laura Alderman and Gary Garcia  
**Interior Designer:** Lydia Corser, Eco Interiors  
**General Contractor:** Rory Howland, Howland Construction  
**Area affected:** 250 ft<sup>2</sup>

*“I’m a big believer in the idea of timelessness. When there is good pleasing design, it stays in place for a long time—people don’t want to change it.”* – Lydia Corser



kitchen before

## Overview and Scope

The owners of this 1200 square foot, 1948 house in Santa Cruz, California had an overall plan: remodel their home in a way that would allow them to live their lives out in one place. Because of mold and moisture issues, they had already upgraded the house envelope. Next they wanted to design a kitchen that would last forever, add a guest bathroom, and create a private master bath. The clients were looking for a way to redesign within the existing space of their concrete masonry home, and were sold on the idea of building green.

## Design Approach

The tiny kitchen was poorly laid out and poorly furnished, but adjoined a large mudroom. Reconfiguring the floorplan to subdivide the mudroom allowed the designer to expand the kitchen and add a guest bathroom without an addition or significant relocation of walls. Because the owners wanted to grow old in the building, every effort was made to ensure accessibility in the open plan. And although this project did not include a photovoltaic or graywater system, the remodel did include pre-wiring for a future PV system and pre-plumbing for graywater.

## Team and Process

Considering whether to hire a pro, the do-it-yourself homeowners were drawn to the unique materials in the Eco Interiors green showroom, and to Lydia’s deep green approach. Lydia and Rory (the contractor Lydia recommended and the homeowners ultimately used) are Build It Green trained and certified. Their common green building background allowed them to easily form a team, recommending and implementing a wide range of green features that the clients would not have considered on their own.



*“It is valuable having someone certified for Kitchen and Bath (Lydia is a Certified Master Kitchen and Bath Designer®) and also being an evangelist for green—a lot of people tout green, but is it really green? Where do you draw the line?”*

– Laura Alderman



Concrete countertop with natural wax finish

*“You have to be on top of the communication to come in at the right time in the process and make your case when the client is listening and open.”*

– Lydia Corser



Built-in eating area



Bamboo and FSC-certified maple cabinets

## Finance

The owners originally wanted to add a granny apartment to their garage, but the price estimate led them to a remodel instead. Ultimately the remodel cost 30-60% more than they budgeted – about the cost of the new construction estimate. Rather than the green features accounting for the extra cost—they had assumed those would add 20-30% to the cost—the additional work orders and add-ons were what drove the cost up. Because they had decided to move out for the work, they realized that this was the now-or-never time to do additional upgrades on the house.

## Lessons and Trade-offs

The clients wanted to go green all the way, and so there were few compromises made.

The house is likely to achieve the first green building award in the City of Santa Cruz Green Building Program, meeting 133-135 out of 137 points available to this project (program total for remodeling projects is 464). The designer’s one regret is the high-VOC finish on the hardwood floors throughout the house, which the client acknowledges as their one non-green choice.

## By System

### Extra Features

- Pre-wired for photovoltaic panels
- Pre-plumbed for a graywater system

### HVAC

- Kitchen range hood exhausted directly outdoors

### Lighting

- Ambient lighting: airtight, insulation-contact-rated, recessed fluorescent cans
- Task lighting: under-cabinet fluorescent lights and over-table light fixtures made from 100% recycled cast aluminum
- Meets California’s title 24 requirements for lighting efficiency

### Appliances

- Energy-efficient dishwasher, clothes washer and dryer—beyond Energy Star
- High-efficiency water heater

### Wall and Ceiling Finishes

- Zero-VOC paint

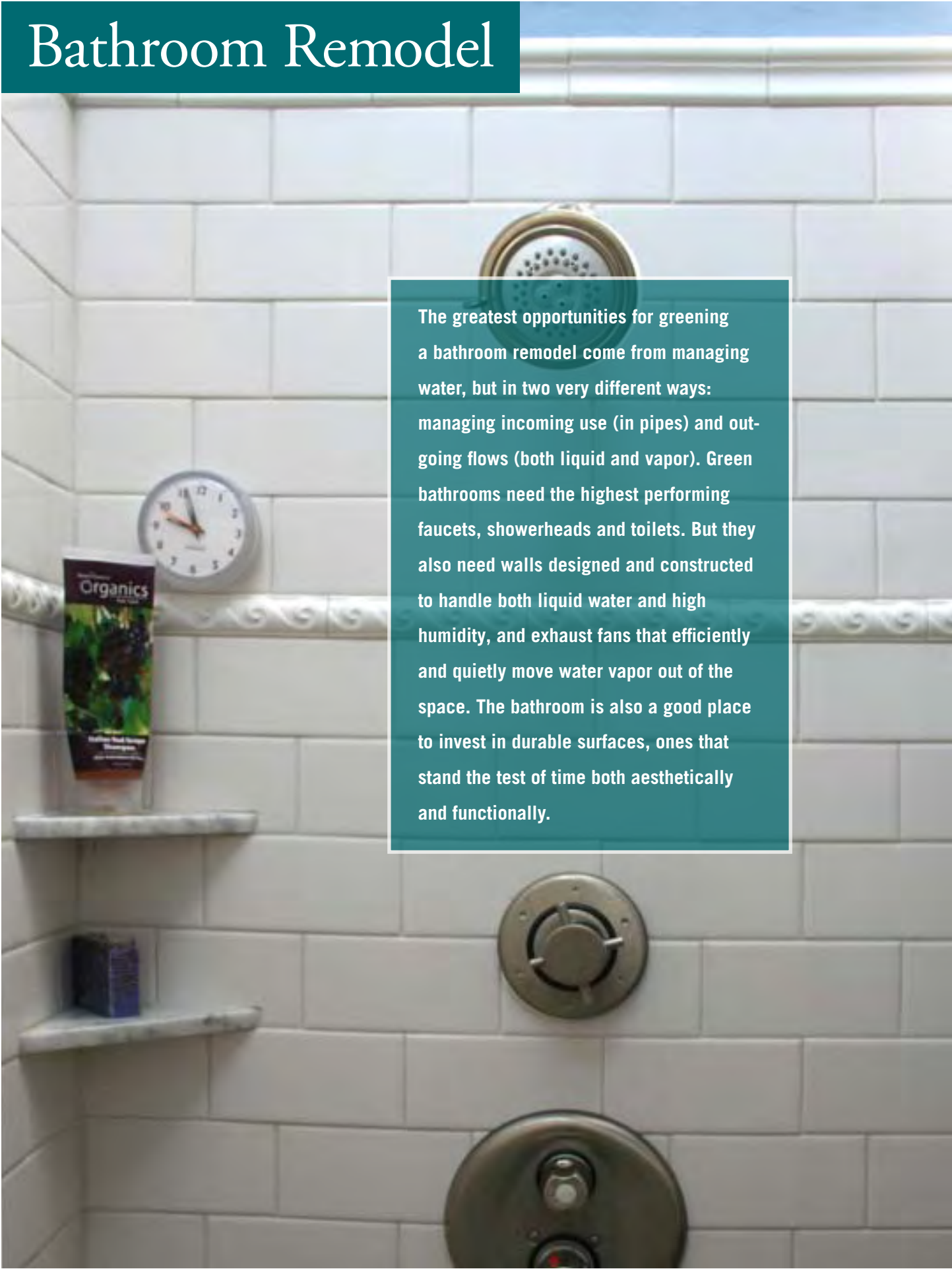
### Floors and Flooring Products

- Natural linoleum flooring

### Furniture and Fittings

- Bamboo cabinetry with a natural low-VOC finish and pre-finished plywood bodies of FSC-certified maple with a formaldehyde-free, soy-based adhesive
- Cabinets with recycled plastic content
- Concrete countertops with locally produced natural wax finish

# Bathroom Remodel



The greatest opportunities for greening a bathroom remodel come from managing water, but in two very different ways: managing incoming use (in pipes) and outgoing flows (both liquid and vapor). Green bathrooms need the highest performing faucets, showerheads and toilets. But they also need walls designed and constructed to handle both liquid water and high humidity, and exhaust fans that efficiently and quietly move water vapor out of the space. The bathroom is also a good place to invest in durable surfaces, ones that stand the test of time both aesthetically and functionally.

# Integrated Pre-Design Issues

## Function

### **What does the homeowner want and what does the homeowner need?**

Bathroom remodeling may be taken on for different reasons: a water leak or moisture intrusion problem that results in the need for structural repairs; a desire to make the bathroom more functional or convenient; family growth that requires bathroom expansion; a change in health or mobility of a family member; a desire to improve the bathroom appearance; or a desire to upgrade appliances and fixtures.

The bathroom represents an important opportunity to weigh the desire for more glamorous amenities that may seldom be used (such as a Jacuzzi or a steam shower), against a desire for a more practical, more convenient, and more resource-efficient space.

## Existing Conditions

### **What functional or performance problems exist in the bathroom that could be addressed at the design level, early in the project?**

- Is there a moisture and/or mold problem that drives the project?
- Have mechanical, electrical, or structural issues arisen that necessitate the bathroom remodel?
- Is the bathroom insufficient in size and layout to function well for the homeowners?
- Have health or mobility issues arisen that necessitate the reconfiguring and outfitting of the bathroom to meet those new needs?

## Scope

### **Are there other remodeling projects that should be considered at the time of a bathroom remodel?**

Any opportunity to improve the home's building envelope should be considered at the time of a bathroom redesign and remodel.

The project might include extensive re-plumbing and rewiring; if any future remodeling projects are being considered, evaluate whether those other projects might be affected by the bathroom remodel and plan accordingly.

Designing for reduced mobility with aging can allow homeowners to live in their homes longer. Selection of taller (ADA-compliant) toilets, wheelchair-accessible sinks and cabinets, and framing to allow later installation of grab bars can be smart and sustainable choices.

## Size

### **Can the bathroom remodel utilize the existing bathroom space or will it require additional space?**

Reconsidering the bathroom function to address new needs and wants might be done by reconfiguring existing space, expansion into adjacent space, or new construction. Rethinking the way existing bath and adjacent space is being used could minimize the amount and extent of remodeling required and the materials involved.

## Layout/Space Planning

### **How will the bathroom space planning strike a balance between utility, aesthetics, and resource efficiency (especially energy and water use)?**

Comprehensive space planning converts the needs expressed by the client into the action-plan for the whole team. While tradespeople may mean different things by the term 'layout,' the whole team needs to be involved in development of floor plans, elevations, and supporting documentation to ensure that the design is optimized across disciplines.



# strategies



## Project Scope

### Includes:

- Interior sheathing and walls
- Windows
- Wet wall design (water management)
- Plumbing fixtures and accessory items
- Domestic hot water system
- Ventilation
- Finishes – trim, flooring, tub/shower surfaces, paint
- Cabinetry
- Laundry room (with living/finished space below)

### Does not include:

- New space or exterior recladding – See Major Addition
- Building envelope and framing – See Home Performance, Major Addition, Gut Rehab, Deep Energy Retrofit
- New heating, cooling or water heating – See Deep Energy Retrofit, Gut Rehab
- Renewable energy – See Deep Energy Retrofit

## Strategies by Building System

### General Design and Construction Strategies

- Ensure durability **IDP1**
- Manage construction and demolition waste **MR107**
- Manage noise **IDP4**
- Design with air quality in mind **IDP5**
- Design for a sustainable lifestyle **IDP6**
- Employ universal design **IDP7**
- Design for storage **IDP10**
- Control the spread of pollutants **IEQ158**

### Building Envelope

- Properly detail window sills in wet areas **IDP26**
- Ensure that window and skylight installation includes proper air sealing and flashing **IDP27**
- Use FSC-certified wood **MR118**

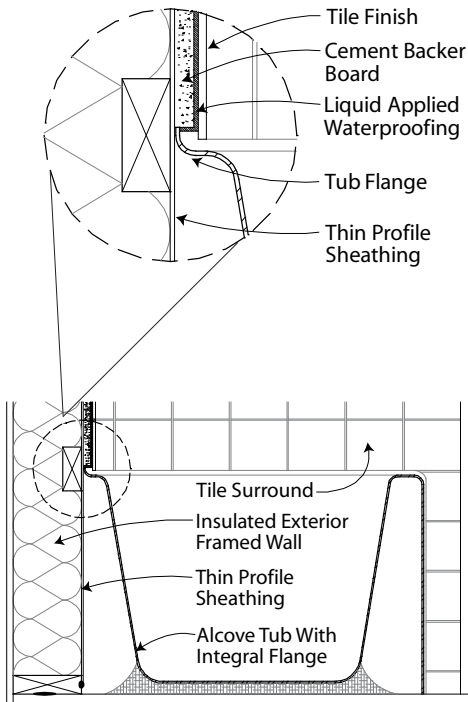
### Lighting and Electrical

- Provide daylighting **EA83**
- Provide appropriate mix of color correct ambient and task lighting **EA84**
- Install energy-efficient electric lighting **EA85**
- Manage phantom loads **EA98**





### Tub Surround Detail



The tub-tile surround transition is a difficult yet critical water management detail.

Note the use of materials impervious to bulk water throughout and the free-draining space between the tub and bottom course of tile. This same detail can be applied to the shower basin-tile surround transition, creating a durable, easy-to-clean, and easy-to-maintain bathing area.

### Plumbing

- Replace toilets with high-efficiency toilets **WE42**
- Install low-water-use showerheads **WE43**
- Install water-conserving bathroom faucet aerator **WE44**
- Install water filter on showerhead **IEQ176**
- Include a plumbing access panel **MR123**
- Choose an efficient hot tub or spa **EA97**
- Choose a high-efficiency water heater **EA79**
- Consider the environmental preferability of piping material **MR122**
- Reconfigure plumbing to distribute domestic hot water efficiently **EA77**

### Laundry

- Install readily-accessible single-throw shut-off valve **MR124**
- Install drain and drain pan for clothes washer located over finished space **MR125**
- Select a high-efficiency, H-axis clothes washer **EA92**
- Provide air-lock dryer vent **EA72**
- Minimize dryer duct length and number of turns **EA73**
- Provide for line drying options for laundry **EA106**

### HVAC

- Install effective bath ventilation **IEQ167**
- Make sure ducting is clean **EA71**

### Wall and Ceiling Finishes

- Frame for installation of future grab bars **MR128**
- Install environmentally preferable interior sheathing **MR126**
- Use non-paper-faced gypsum board in moist areas **IEQ183**
- Limit use of wallcoverings in high moisture areas **IEQ184**
- Consider tile and tile trim pieces with recycled content **MR132**
- Use low- or zero-VOC interior paints and finishes **IEQ185**
- Use appropriate sheens for paints and finishes **MR130**
- Use low- or zero-VOC construction adhesives, grouts, caulking, and sealants **IEQ187**

### Floors and Flooring Products

- Consider reuse of existing flooring and subflooring **MR133**
- Avoid carpeting in high moisture areas **IEQ179**
- Choose hard-surface flooring **IEQ180**

### Furniture and Fittings

- Choose furniture and fittings that will not absorb moisture **IEQ188**
- Consider reusing clean existing furnishings and fixtures or buying salvaged **MR141**
- Evaluate use of cabinetry and furniture made from particleboard or MDF **MR145**
- Select materials that are easy to clean **MR156**
- Purchase the best, most durable furniture possible within a given budget **MR143**
- Select cabinets made from greener materials **MR148**
- Install environmentally preferable countertops **MR149**

### Use

- Set water temperatures no higher than necessary **EA82**
- Use environmentally preferable cleaning materials and strategies **IEQ196**
- Consider using bulk-product dispensers for body care products **MR157**
- Educate homeowner for green living **EA103, EA104, EA105**

# case study

**Location:** Clearwater, Florida  
**Homeowner and Environmental Consultant:** Debra Lynn Dadd  
**Homeowner and Amateur Builder:** Larry Redalia  
**Area affected:** 40 ft<sup>2</sup>

*“Storage was a challenge in this small bathroom, as there just wasn’t space to put a cabinet or a spacious vanity. Our solution was to pare down the essentials that needed to be stored in the bathroom and then be creative.”* – Debra Lynn Dadd



bathroom before

## Overview and Scope

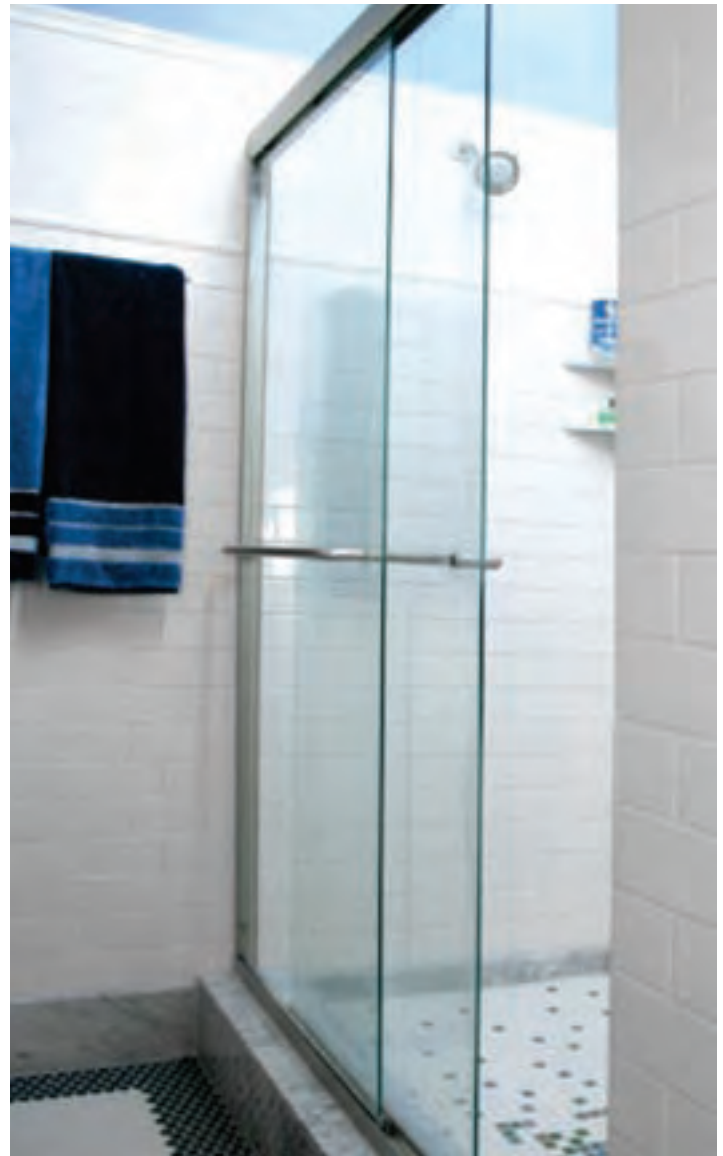
With a 5' x 8' bathroom combining 1960s décor with original features from 1940, the homeowners hoped to renovate eventually when they could budget it. They ended up acting faster upon discovering that mold in the bathroom was the cause of their recent respiratory and sleep problems. A house inspection team uncovered the mold infestation and recommended taking the bathroom down to the studs for full remediation. The couple took advantage of the problem to create a visually appealing, nontoxic, and mold-resistant bathroom within the existing space. While also keeping in mind future resale, they tailored the bathroom to meet their needs.

## Design Approach

The old bathroom had no ventilation, causing consistently high humidity, and leaks from the bathroom’s corroded galvanized steel pipes had saturated the floor around the tub and toilet areas, damaging the floor and subfloor. The couple’s highest priority was to create a durable bathroom that would stay mold-free. This meant proper detailing and rethinking plumbing, ventilation, and finishes. They also wanted a nontoxic bathroom with as many additional environmental features and materials as their budget would allow – all within the existing small space. They chose a bathroom theme celebrating water and nature as works of art, and a style befitting an average suburban home, making it suitable for resale.

## Team and Process

Taking one year to complete the project, the couple hired skilled contractors to do the mold remediation, plumbing, and



electrical work, but did the finish work themselves. An extra toilet in the house and a shower in their rental property nearby provided them the flexibility to take whatever time they needed. Concerned about future leaks, they made sure to research correct tile shower installation. Larry first installed cement backerboard underlayment on walls and floor (avoiding paper-faced greenboard, which should not be used behind tile). He then used nontoxic, thin-set mortar to hold the tile, and applied nontoxic grout and grout sealer to finish the job. Their research on tile shower installation led Larry to follow the methods and materials of Ontario Tile Setters ([www.debraslist.com/greenbathroom/showerpan.pdf](http://www.debraslist.com/greenbathroom/showerpan.pdf)).

*“Read and understand the directions thoroughly before starting such a project.”*

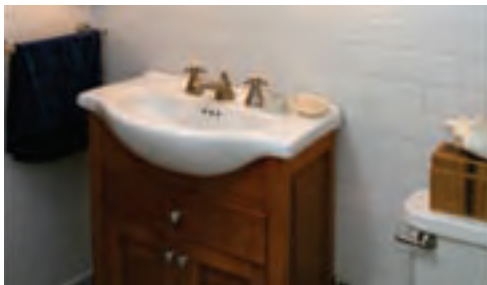
– Larry Redalia



Skylight in shower stall

*“Home improvement stores will often give you an excellent deal on slightly-damaged or opened cartons, but you need to ask for it first.”*

– Debra Lynn Dadd



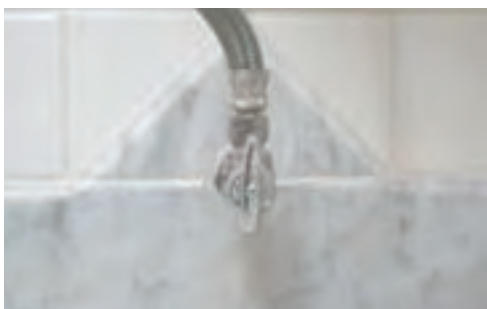
Space-saving sink and vanity



Durable shower pan – under construction



Durable shower pan – finished



Wall tile-marble detailing

## Finance

Debra and Larry had not budgeted for this emergency bathroom remodel. Although their insurance paid for basic mold remediation, including full containment and negative pressurization of the bathroom, it did not cover the cost of updating fixtures, furnishings, or finishes. By performing much of the design and construction themselves, the couple could budget more for materials and consider durability and style, in addition to affordability, in purchase decisions. They also shopped architectural salvage yards to acquire, at lower cost, quality materials such as handmade tile.

## Lessons and Trade-offs

The homeowners found they had to make a number of compromises in order to meet their budget for the project. Although they used nontoxic finish products, and prioritized durability in aspects such as plumbing and tiling, the couple passed on other, less affordable features such as recycled-content tile and organic cotton towels. Because Larry performed so much of the actual work, he was less prepared for the unknown than a professional may have been: while mixing the mortar for the tiled shower pan, Larry discovered—too late—that the instructions he had didn’t match the included illustrations.

## By System

### HVAC

- Ventilation ducted to outdoors

### Plumbing

- Low-flow fixtures for sink, toilet, and shower
- Low-flow shower heads designed for efficiency; not retrofitted with flow-restrictors

### Lighting

- Natural lighting provided by a skylight over the shower

### Finishes

- Tile floor and tile walls throughout the bathroom, with unique tiling pattern in the shower area
- Durable marble baseboard
- Breathable (natural-colored) clay plaster finish
- Nontoxic grout and grout-sealer
- Water-proof detailing

### Use

- Nontoxic (natural) body products
- Nontoxic cleaning products



# Bedroom Remodel

Most of us spend more time in our bedroom than in any other room in our home, so it makes sense that materials installed and resulting air quality in these spaces should be the cleanest and healthiest possible.

The time spent in bedrooms includes about eight hours out of each 24-hour day sleeping, which should be restorative for our bodies and our spirits. Healthy air, confidence about potential hazards, such as electromagnetic fields, and relaxing aesthetics all contribute to the sense of well-being that should be found in bedrooms. The bedroom may be the only place a homeowner can find a quiet, private respite from a hectic lifestyle. And when we are ill, the bedroom needs to be a space that supports healing.



# Integrated Pre-Design Issues

## Function

### What was the motivation to remodel the bedroom space?

The remodeling and renovation of any interior space can be driven by many factors: the desire to create more usable spaces; the desire to replace worn-out furniture or equipment; the need to create a healthier environment for those with allergies, asthma, or other sensitivities; or the desire to improve aesthetics alone. Regardless of the driving force behind the renovation, several things need to be kept in mind through the early design-decision making process.

Because our bedrooms play such an integral role in our health maintenance—in providing that good night’s sleep, offering a quiet retreat from our hectic lives, and allowing a healing space for our bodies and spirits—it is important to keep health issues at the top of our list in our bedroom design choices.

## Existing Conditions

### What functions or performance problems exist in the bedroom space that could be addressed at the design level, early in the project?

- Do the issues that need correcting in the existing bedroom include problems caused by moisture intrusion from the adjacent bathroom, or other water-compromised areas of the house such as crawl space, or due to poor perimeter drainage?
- Do the issues that need correcting in the existing bedroom include offgassing from VOCs in finishes or other materials, or release of other potential harmful chemicals that may be released from building products or components, such as flame retardants, heavy metals, plasticizers, or biocides?
- Does the bedroom need improved air quality during the nighttime hours while we sleep?
- Are windows in poor shape and in need of replacement, and do they still open for fresh air?

## Scope

### Are there other remodeling projects that should be considered at the time of a bedroom remodel?

Although not the overarching issue driving a bedroom remodeling project, such a project may present an opportunity to make other improvements in the home at the same time.

## Size

### Can the bedroom remodel utilize the existing bedroom space or will it require additional space?

Additional space may be a driver with a bedroom remodel, but homeowners should consider this carefully. Bedrooms may become repositories for “stuff,” giving homeowners the feeling that they need more space. But by taking the time to reduce that accumulated stuff—too much clothing, too many shoes—the need for new space may be reduced or even eliminated. Also, a more clutter-free bedroom allows for a cleaner and healthier space.



# strategies



## Project Scope

### Includes:

- Wiring and appliances
- Additions, upgrades and improvements to main HVAC System
- Wall, ceiling, and woodwork finishes
- Flooring
- Window treatments
- Furniture
- Mattress and bedding
- Lighting
- Accessories

### Does not include:

- New space or exterior recladding – See Major Addition
- Building envelope and framing – See Home Performance, Major Addition, Gut Rehab, Deep Energy Retrofit
- New heating, cooling or water heating – See Deep Energy Retrofit, Gut Rehab
- Moisture management – See Gut Rehab, Major Addition, and Deep Energy Retrofit
- Renewable energy – See Deep Energy Retrofit

## Strategies by Building System

### General Design and Construction Strategies

- Ensure durability IDP1
- Manage noise IDP4
- Design with air quality in mind IDP5
- Design for a sustainable lifestyle IDP6
- Manage construction and demolition waste MR107

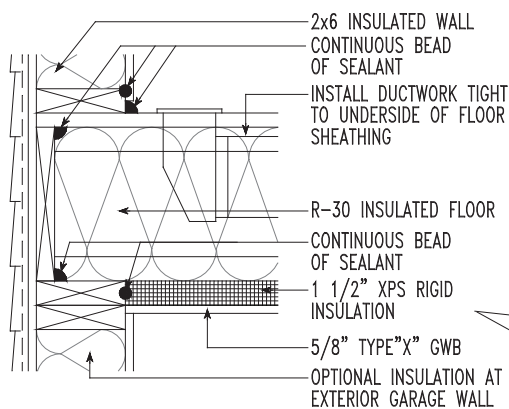
### Building Envelope

- Isolate attached garages IEQ165
- Control the spread of pollutants IEQ158
- Use FSC-certified wood MR118

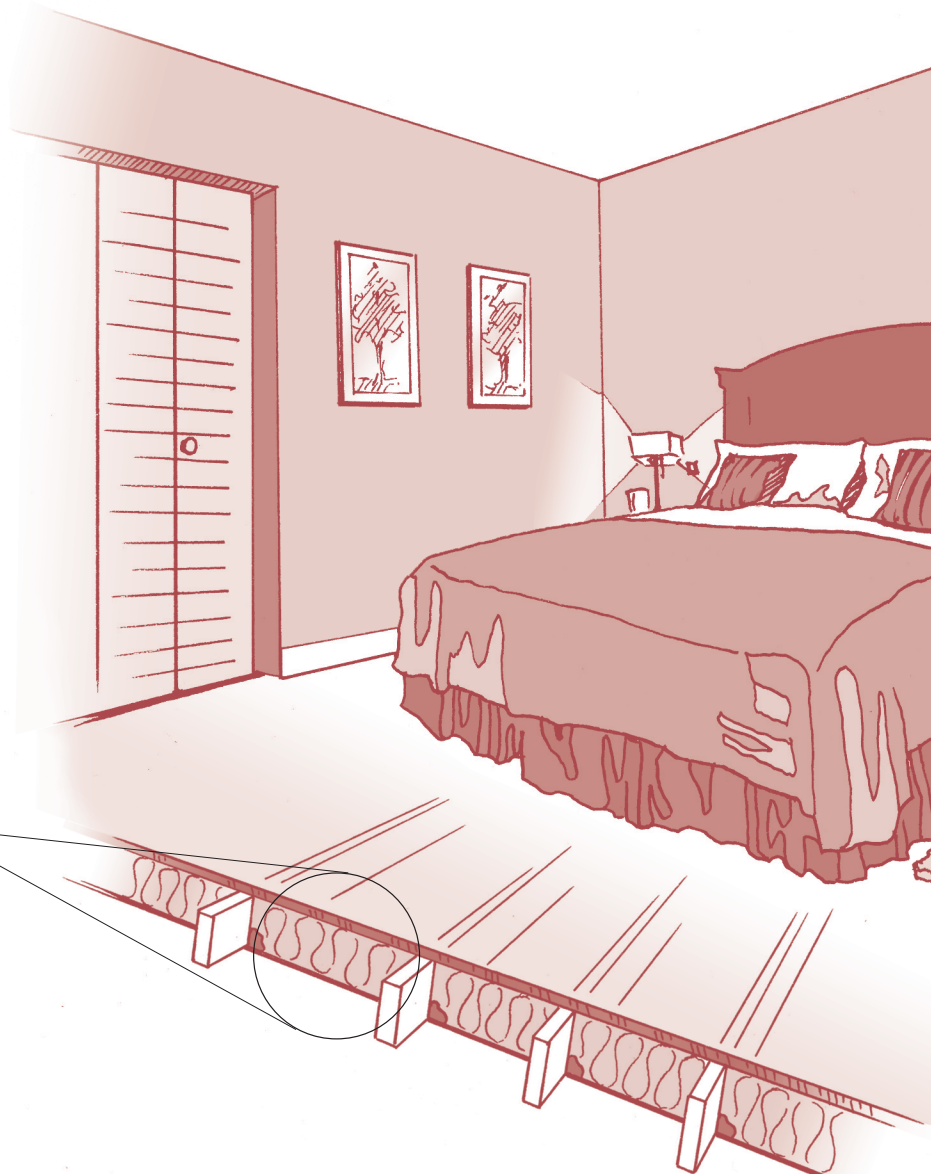
### HVAC

- Provide for forced-air system pressure relief IEQ170
- Provide fresh air as part of ventilation system IEQ171
- Make sure ducting is clean EA71

### Attached Garage Air Sealing Detail



*This detail shows how to achieve proper isolation (continuous air and thermal barrier) between an attached garage and any adjacent living space.*



### Lighting and Electrical

- Provide daylighting **EA83**
- Use prudent avoidance with electromagnetic fields **IEQ177**
- Provide appropriate mix of color correct ambient and task lighting **EA84**
- Install energy-efficient electric lighting **EA85**
- Provide controllable interior shading **IEQ178**
- Manage phantom loads **EA98**

### Wall and Ceiling

- Install environmentally preferable interior sheathing **MR126**
- Select environmentally preferable interior doors **MR127**
- Use low- or zero-VOC interior paints and finishes **IEQ185**
- Consider natural finishes **MR131**
- Use appropriate sheens for paints and finishes **MR130**
- Consider alternative wallcovering products **MR129**
- Limit use of VOC emitting wallcoverings **IEQ186**

### Floors and Flooring Products

- Consider reuse of existing flooring and subflooring **MR133**
- Select wood subflooring that is FSC-certified and low-formaldehyde **MR134**
- Choose hard-surface flooring **IEQ180**
- Consider flooring made from certified or reclaimed wood **MR135**
- Consider flooring made from natural or rapidly renewable materials **MR136**
- Refinish wood floors using environmentally preferable processes and products **MR137**
- Install area rugs instead of wall-to-wall carpeting **IEQ182**
- Choose environmentally preferable carpet and rug products **MR138**
- Select carpet cushion that does not contain brominated flame retardants **MR139**

### Furniture and Fittings

- Consider cleaning existing furniture or purchasing salvaged/antique furniture **MR142**
- Purchase the best, most durable furniture possible within a given budget **MR143**
- Select solid furniture that is made from green and safe sources **MR147**
- Select furniture from suppliers that are practicing fair and safe manufacturing processes **MR150**
- Minimize use of plush and porous materials **IEQ191**
- Choose environmentally preferable fabrics **MR152**
- Choose furniture finished with least-toxic products **IEQ189**
- Select furniture that is easy to clean **IEQ192**
- Select window treatments with health considerations in mind **IEQ193**
- Select mattress and bedding with attention to health issues **IEQ194**
- Choose interior accessories with care **IEQ195**
- Support local artisans as well as indigenous peoples **MR153**
- Select upholstered furniture with care **MR151**
- Avoid fully upholstered furniture where moisture may be a problem **IEQ190**

### Use

- Use environmentally preferable cleaning materials and strategies **IEQ196**
- Educate homeowner for green living **EA103, EA104, EA105**



# case study

**Location:** Valley Village, California  
**Homeowners:** Mary Cordaro and Scott Jones  
**Certified Bau-Biologist and Environmental Consultant:** Mary Cordaro, Industry Partner member of ASID  
**Area affected:** 200 ft<sup>2</sup>

*“One of the things I always teach is that you are not going to have a healthy bedroom without good perimeter drainage.”* – Mary Cordaro



bedroom before

## Overview and Scope

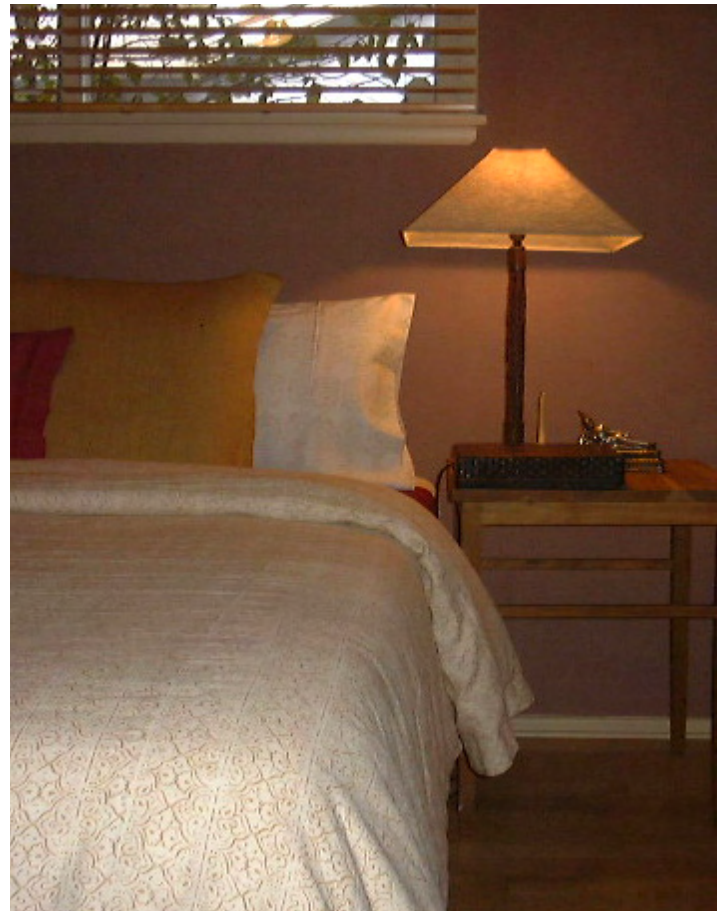
This bedroom, along with the rest of the 1950s house, has undergone a slow transformation to an all-natural space, free of allergens, and synthetic chemicals. Through a series of renovations that began in 1990, Mary Cordaro has updated her home according to recent advances in building science and the principles of Bau-Biologie (German for “building with life”). Because Bau-Biologie focuses on the bedroom, where people spend the majority of their time, Mary has concentrated her renovation efforts on her own bedroom. The last major change, in 2002, involved swapping environmentally friendly synthetic finishes for natural finishes. The allergen-free bedroom now includes organic bedding materials in addition to natural finishes, and attention has been given to minimizing electromagnetic fields (EMFs).

## Design Approach

Renovation of the house is a work in progress. Renovations in the 1990s did away with the décor from the 1970s. In the bedroom, green shag carpeting was replaced with maple hardwood flooring, and a synthetic, zero-emitting floor finish. As the Bau-Biologie principles evolved, and more durable and easy-to-apply natural finishes became available, Mary replaced synthetic finishes with newly available natural finishes. She keeps a running list of changes to be made as time and finances allow.

## Team and Process

Mary is part of a cross-disciplinary team of independent consultants and contractors that worked together on her house, as well as on other projects in the Los Angeles area. The team includes an HVAC installer trained in building science, an electrician with special training in reducing EMFs, a natural painting crew, a building science and Bau-Biologie trained environmental inspector who ensures that there are no water intrusion or moisture issues, and Mary, the Bau-Biologie project manager and materials specialist.



*“It makes such a huge difference to be in an environment that is as free as possible from the pollutants most homes have—in indoor air, but also from the outdoors. We live in a very smoggy urban environment, so this is a great house to try to make as healthy as possible under the worst conditions.”* – Mary Cordaro

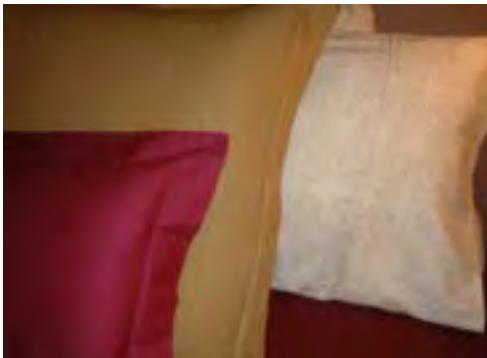


Antique reclaimed Japanese reed screen

*“I’m not worried about durability with natural finishes—we don’t wear shoes in the house, and the flooring finish I would now use is just as durable as many green, synthetic, water-based finishes. It also allows for touching up high-traffic areas without sanding and refinishing the whole room.”* – Mary Cordaro



Bio-based paint



Organic flame retardant-free bedding



Personal space HEPA air filtration

## Finance

Although natural finishes are becoming more available, affordable, and manageable, they still tend to be more expensive to purchase and apply than a synthetic equivalent. Rather than compromising on natural finishes, however, the homeowners chose to do renovations room by room, over time, as finances permitted.

## Lessons and Trade-offs

Because of the long-term nature of this retrofit, Mary experienced the blessing and curse of hindsight throughout the process. As new products became available and Bau-Biologie principles evolved, Mary identified things that she would have done differently if she had it to do over. Early in the process, she reinsulated the attic with a new insulation material that turned out to be friable. This creates a lot of dust when changes are made to HVAC and lighting, all located in the attic; cotton or cellulose insulation would be her preferred materials today, installed in the ceiling of the attic to create a conditioned attic. Similarly, the team initially used water-based, zero-emitting paints and floor finish, but would now choose only natural finishes.

## By System

### Wiring

- Shielded and grounded cables
- Minimal EMFs, both low-frequency and high-(radio) frequency, and no Wifi
- Bed shield for any remaining EMF levels

### HVAC

- Forced air system installed airtight for energy efficiency, positive pressure, fresh air dilution, and filtration.
- Room high-efficiency particulate air (HEPA) and carbon filter with shielded cable for low EMFs
- Whole house HEPA and carbon air filtration system

### Wall and Ceiling Finishes

- Naturally pigmented mineral and bio-based paint for walls, ceilings, and woodwork

### Floors and Flooring Products

- Solid maple hardwood flooring
- Water-based clear acrylic finish with low volatile organic compounds (VOCs)

### Furniture and Fittings

- Mattress foundation made of FSC-certified wood
- Mattress made of organic cotton and wool and natural latex instead of inner springs
- Organic bedding materials free of flame retardant chemicals and synthetic materials
- Linens made from hemp, silk, and organic cotton
- Window coverings are basswood wood blinds, and antique (reclaimed) Japanese reed screen



# Living & Working

It's hard to find homes with traditional living space configuration—kitchen, dining room, living room, den—that have not gone through some degree of reconfiguration based on more contemporary lifestyles and shared rather than separate functions: work spaces in the kitchen or living room, entertainment in the den, dining in the kitchen. When remodeling green, the goal is to rework existing spaces for new or combined functions rather than add new spaces.





# Integrated Pre-Design Issues

## Function

### **What does the homeowner want and what does the homeowner need?**

What motivates the desire or need to reconfigure the living and working spaces in the home? Have lifestyle and work requirements changed to necessitate the re-purposing of a space to allow for the performance of multiple tasks in a designated room? Can these lifestyle- and work-change needs be met without additional new rooms and square footage? Instead, can there be the re-designing of an existing room to be multi-purposed and more flexible to support these changes?

Is there a desire to keep better connected with family members throughout the day? Can a single, well-thought-out room allow for parents and children to task independently, but in the same space?

Is there a need to replace or upgrade flooring and/or furnishings, driven either by personal changes, or is this a home with new owners?

## Existing Conditions

### **What functions or performance problems exist in the home's general living spaces that could be addressed at the design level, early in the project?**

Are there rooms in the home that are under-utilized and do not fit with the family's current lifestyle, such as a separate living room that sits vacant, or a formal dining room that is used once a year for a holiday get-together?

Is there thermal discomfort, inadequate lighting, poor indoor air quality, or poor acoustics driving the decision to remodel?

## Scope

### **Are there other remodeling projects that should be considered at the time of the living and working space remodel?**

Designing a new multi-tasking living and working space is an excellent opportunity to examine daily lifestyle patterns of activity, how these activities and family members interface with each other, and to determine how fully all areas of the house are being used.

## Size

### **Can the living and working space merge other rooms of the home to create a more concise area without adding square footage?**

An evaluation of room use combined with an assessment of how well existing rooms might accommodate combined uses will reveal which room can best meet the new combination of uses or which rooms can be reconfigured or even joined for multi-purpose living and working space.

## The Long Term

### **Is the reconfiguration designed for flexible or more permanent long-term combined uses?**

Does the plan for reconfiguration cover anticipated future uses of spaces (based on an aging-in-place approach or a general "marketability" of the new spaces/combined functions)?

## Integrated infrastructure

### **Does the plan integrate passive design and active mechanical/electrical infrastructure?**

Has the proper consideration been given to the electrical/mechanical configuration of the new multi-functional space—plug load, lighting, space conditioning, ventilation—and its integration with natural ventilation, daylighting, and fenestration?

# strategies



## Project Scope

### Includes:

- Wiring
- Furnishings
- Lighting
- Electronic equipment
- Floor finishes

### Does not include:

- New space or exterior recladding – See Major Addition
- Building envelope and framing – See Home Performance, Major Addition, Gut Rehab, Deep Energy Retrofit
- Interior wall finishes – See Bedroom
- New heating, cooling or water heating – See Deep Energy Retrofit, Gut Rehab
- Renewable energy – See Deep Energy Retrofit
- Windows and exterior door – See Gut Rehab

## Strategies by Building System

### General Design and Construction Strategies

- Ensure durability IDP1
- Manage noise IDP4
- Design for a sustainable lifestyle IDP6
- Optimize interior layout IDP8
- Design for storage IDP10
- Manage construction and demolition waste MR107
- Plan for the future with wiring and cabling needs MR121
- Use FSC-certified wood MR118
- Control the spread of pollutants IEQ158

### HVAC

- Provide fresh air as part of ventilation system IEQ177
- Provide for additional ventilation and air conditioning needs in certain activity areas IEQ172
- Make sure ducting is clean EA71



### Lighting and Electrical

- Provide daylighting **EA83**
- Design appropriate mix of color correct ambient and task lighting **EA84**
- Install energy-efficient electric lighting **EA85**
- Provide adaptable lighting for multi-use spaces **EA87**
- Manage phantom loads **EA98**
- Provide controllable interior shading **IEQ178**

### Equipment

- Manage phantom loads **EA98**
- Select energy-efficient Energy Star-rated office equipment **EA99**

### Floors and Flooring Products

- Consider reuse of existing flooring and subflooring **MR133**
- Select wood subflooring that is FSC-certified and low-formaldehyde **MR134**
- Choose hard-surface flooring **IEQ180**
- Consider flooring made from certified or reclaimed wood **MR135**
- Consider flooring made from natural or rapidly renewable materials **MR136**
- Refinish wood floors using environmentally preferable processes and products **MR137**
- Use area rugs instead of wall-to-wall carpeting **IEQ182**
- Choose environmentally preferable carpet and rug products **MR138**
- Select carpet cushion that does not contain brominated flame retardants **MR139**

### Furniture and Fittings

- Consider cleaning existing or purchasing salvaged/antique furniture **MR142**
- Purchase the best, most durable furniture possible within a given budget **MR143**
- Select ergonomic furniture and office equipment **MR144**
- Select solid furniture that is made from green and safe sources **MR147**
- Select furniture from suppliers that are practicing fair and safe manufacturing processes **MR150**
- Select upholstered furniture with care **MR151**
- Avoid fully upholstered furniture where moisture may be a problem **IEQ190**
- Minimize use of plush and porous materials **IEQ191**
- Choose environmentally preferable fabrics **MR152**
- Choose furniture finished with least-toxic products **IEQ189**
- Select window treatments with health considerations in mind **IEQ193**
- Choose interior accessories with care **IEQ195**
- Support local artisans as well as indigenous peoples **MR153**
- Provide for paper recycling **MR155**
- Educate homeowner for green living **EA103, EA104, EA105**

# case study

**Location:** Mill Valley, California  
**Homeowners:** Pam and Tim Sowerby  
**Interior Designer:** Victoria Schomer, ASID, LEED AP,  
Green Built Environments  
**Area affected:** 400 ft<sup>2</sup>

*“I encourage clients to use existing and antique pieces. And when they buy, to buy really good quality long-lasting furniture—not throwaway furniture”*

– Victoria Schomer



living room before

## Overview and Scope

Before renovating the living room, there was no office space in the house. Pam Sowerby needed a functioning workstation so that she could do computer work at home while taking care of her children. Pam contracted interior designer Victoria Schomer to turn the living room into a multi-functional and healthy space for the family of four. The client’s chemical sensitivities made selecting low-emitting materials a necessity.

## Design Approach

Pam wanted to be able to work in the room, but also use it as a living room for the family and guests. The living room also needed to have a space for the kids to do homework and play while Pam was on the computer. Some smaller-scale furniture was chosen to creatively maximize the uses for this limited space. The desk is a self-contained office space that can be closed up to look like an armoire. The coffee table includes four small matching stools that the children can use, or that can be pushed under the table for an uncluttered living area.

## Team and Process

Pam and Victoria have worked together for many years and have developed an effective approach for managing Pam’s chemical sensitivities; before any final purchasing decision was made, all furnishings and finishes, including samples of every component going into custom made furniture, were given to Pam to self-test for a health reaction.



*“I had a big exposure about 20 years ago and ever since then I’ve been really sensitive. I need to avoid formaldehyde as much as possible; lots of glues, flame retardants on upholstery I react to. Over the years I also became more concerned with the environment.”* – Pam Sowerby





Coffee table/children's work station

*“I find it's not always so difficult to make an attractive room for someone with chemical sensitivities. A growing number of manufacturers are paying attention to what they're using in their products. Greener, safer furnishings don't always have to be expensive.”* – Victoria Schomer



Living and working space



Hide-away work station

## Finance

Dealing with chemical sensitivities sometimes adds costs. Pam and Victoria had trouble finding a green furniture manufacturer for the kind of desk they desired. They worked around this by ordering the desk unfinished and having a low-emitting finish applied locally. The manufacturer, however, charged the full price for the unfinished product. In general, they focused on purchasing good-quality, durable, and healthy furnishings, and decisions were made slowly to ensure that each purchase would really work.

## Lessons and Trade-offs

Furnishings do not always fit the space as anticipated. At first the filing cabinet appeared too big for the living room. Moving it by the sofa to use as an end table solved the problem. Spending the time to really think about the uses of the room, and in particular, how Pam uses a desk, helped them design and furnish the room so that it truly met the needs of the family. During the day, Pam uses the desk for her work, and her children use the coffee table and stools when they want to be close to their mother. On Friday evenings, they close the desk, pull up chairs from the dining room, and seat a church group of ten to twelve people.

## By System

### Building Envelope

- Existing energy-efficient windows
- No window treatments used or needed

### Lighting

- Daylighting
- Compact fluorescent lamps
- Mix of task and ambient light

### Wall and Ceiling Finishes

- Paint with low volatile organic compounds

### Floors and Flooring Products

- Existing carpet remained

### Furniture and Fittings

- Self-contained and easily hidden desk
- Coffee table with tuck-under seats for children
- Antique desk chair
- Custom sofa and upholstered chair with low-emitting fabrics and components
- Fabrics without surface treatments, self-tested by client for chemical sensitivity
- Kid-friendly (dark; patterned; textured) fabric for durability and to minimize cleaning

### Equipment

- Energy Star laptop computer


### Use

- Shoes off in the house help to keep the carpet clean

# Finished Basement

## Green From the Start

Just a 'Green From The Start' reminder about the home performance audit and interior space planning; they are particularly important for this project.



For many existing homes and their households, the finishing of a basement represents one of the easiest and least expensive ways to increase the living space of their home. But the basement can also be one of the most difficult in terms of the building science involved and overall indoor environmental quality. Managing moisture and radon, introducing daylight, and selecting the right materials from insulation to finish flooring are all challenging. And, oddly, changing the way in which the attic performs may be key to changing the way the basement performs, in terms of energy efficiency and indoor air quality. Finishing a basement may seem like an ideal do-it-yourself project, but it can also be one for which a bit of up-front professional design or consultation can mean the difference between a problem project and a green, high-performance one.

# Integrated Pre-Design Issues

## Building Code Issues

**Are there building code issues, such as egress requirements or floor-to-ceiling height requirements, where there could be synergy or conflict with energy efficiency or durability strategies?**

Finished basement egress requirements can mean designing in rather large window well units (at least 5.7 square feet) that can also increase the livability of the space by introducing daylight. On the other hand, these window units will have a significant impact on the energy performance of the basement (increasing the wintertime temperature difference from just 20 °F for earth-sheltered basement walls to as much as 50 °F to 70 °F for welled windows). In addition, window well units must be properly detailed for water management so that they don't introduce a moisture problem along with the safety and daylighting benefits.

Finished floor-to-ceiling height minimum requirements can make it difficult to properly address moisture transmission from the basement slab into the new living space or properly address thermal comfort and condensing surface issues if, as is very likely, the existing basement floor has no thermal insulation or capillary break material beneath it. While the energy lost through the basement slab to the soil below is relatively minor in the overall energy performance of the basement, a lack of thermal insulation can contribute to thermal comfort problems and a basement finished floor temperature that accommodates condensation or relative humidity high enough to support mold and dust mites. Check to see if the finished floor-to-ceiling height permits the addition of rigid insulation, a sleeper assembly, or both.

## Basement as Healthy Living Space

Not all basements become space for living. But when possible, and if well-thought-out, the incorporation of this valuable square footage for a family room, or functions other than sleeping, is a good use of existing indoor space. But basements are below grade so, by nature, have higher moisture levels. Creating healthy, light-filled environments in a basement presents many challenges. The first step should be a professional home performance audit. Moisture control can be addressed through judicious attention to all wall and floor details to keep moisture away. Choose the best light-filled, driest area in the basement to make a livable room. Address ventilation and humidity separately from the whole house mechanicals if needed. When furnishing, avoiding as much porous materials as possible, such as carpet, fabric and upholstered goods. Be attentive to other toxic items that might be stored in the basement that can impact the living space. And consider that acoustical issues might arise when living space is near to mechanical systems.

## Soil gases

**Has the unfinished basement been assessed for soil gas problems, including but not limited to, radon?**

The list of potentially hazardous materials that can be in, on, or even under older homes is dishearteningly lengthy—lead, mold, asbestos, persistent pesticides, coal dust, creosote, etc. Care must be taken to determine whether or not these substances are a part of the project, and if so, are they best handled with professional removal or complete encapsulation.

## Moisture problems/potential

**How might increases in the energy efficiency of the building envelope shift existing moisture loads from an equilibrium to a moisture problem?**

Energy flow through building assemblies dries them out. So, when finished basements are made more energy-efficient and reduce the energy flow through basement wall and floor assemblies, moisture issues that were being handled by the basement assemblies can turn into moisture problems that they cannot handle. Assess moisture management at the site level (gutters and downspouts, finished grade sloped away from the structure on the entire perimeter), in the wall assemblies (dampproofing and footer drainage), and in the floor (free-draining fill and capillary break beneath the slab). The latter two can be assessed by visual inspection during heavy precipitation events, with moisture meters, and with the ASTM D4263 Plastic Sheet test ([www.astm.org](http://www.astm.org)) or the more-sophisticated ASTM F1869 Calcium Chloride test ([www.astm.org](http://www.astm.org)).

## Passive Survivability

**Do local environmental conditions suggest inclusion of design for passive survivability in the finished basement space?**

Passive survivability is "...a building's, ability to maintain critical life-support conditions if services such as power, heating fuel, or water are lost..." (*Environmental Building News*, May 2006). In many (but not all) areas of our country, a dedicated area of the basement could be outfitted to sustain its occupants during and after events such as hurricanes, tornadoes, winter storm outages, even nuclear events. Designing passive survivability space into a finished basement may well be a sustainability strategy for many homes.

## Existing Mechanical Systems Located in the Basement

**Are there non-sealed combustion or non-power vented gas appliances or mechanical equipment in the existing unfinished basement?**

Although the plan to finish a basement does not have to involve upgrading existing space heating or domestic water heating equipment, it is something to consider at the pre-design stage because of indoor air quality and space implications. Sealed combustion furnaces and boilers, and power-vented gas water heaters are not only more energy efficient, they eliminate dangerous back-drafting potential, usually take up significantly less space than their older, naturally-drafting counterparts, and do not necessarily have to be located adjacent to a chimney or straight-shot chase. Switching out to these systems can keep the finished basement safe in terms of indoor air quality and free up spaces and configurations.

Every one of the concerns outlined above, and described in the following three design issues, could be revealed by a professional home performance audit.



## Project Scope

### Includes:

- Building envelope
- Vapor profile
- Framing
- Floor framing (sleeper assembly)
- Interior finishes
- Furnishings and lighting
- Exterior cladding
- Space conditioning
- Domestic hot water system

### Does not include:

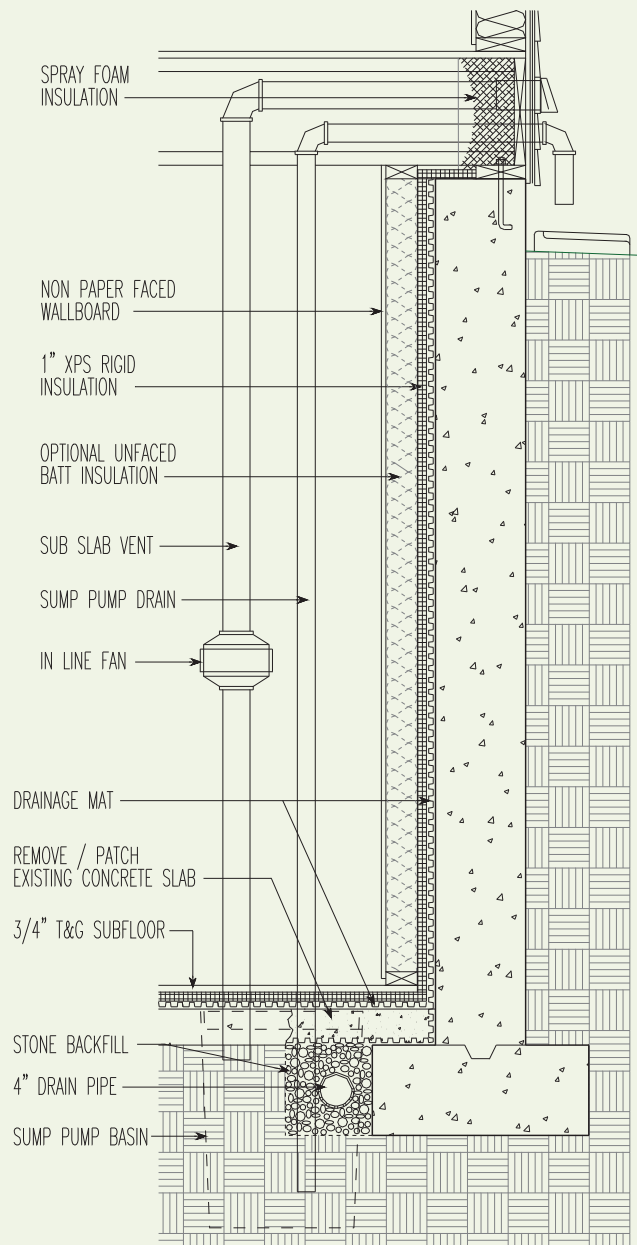
- New space or additional cladding – See Major Addition
- “Wet” rooms – kitchen, bath or laundry - See Kitchen and Bathroom
- Appliances and equipment – See Deep Energy Retrofit
- Renewable energy – See Deep Energy Retrofit

## Strategies by Building System

### General Design and Construction Strategies

- Ensure durability IDP1
- Conduct a home performance audit IDP2
- Manage noise IDP4
- Design with air quality in mind IDP5
- Design for a sustainable lifestyle IDP6
- Assess vapor profile of new assemblies IDP25
- Manage construction and demolition waste MR107
- Control the spread of pollutants IEQ158
- Test for, and appropriately handle, hazardous materials IEQ159
- Use FSC-certified wood MR118

### Basement Wall Section at Sump Pump Detail



Technical Illustration: Steve Baczek, AIA



### Foundation

- Install a radon mitigation system **IEQ163**
- Provide appropriate insect control **IDP23**

### Building Envelope

- Upgrade basement floor **IDP20**
- Upgrade exterior basement walls **IDP21**
- Include capillary break between all concrete and sill plates **IDP22**
- Airseal/insulate rim joists **IDP55**

### HVAC

- Install appropriate HVAC in the finished basement **IEQ174**
- Provide appropriate venting of all combustion-based heating and water heating equipment **IEQ168**
- Consider stand-alone equipment to address moisture and air quality **IEQ169**
- Install CO and smoke alarms **IEQ164**
- Make sure ducting is clean **EA71**

### Plumbing

- Choose a high-efficiency water heater **EA79**
- Insulate water heater **EA80**
- Insulate hot water pipes **EA81**
- Set water temperature no higher than necessary **EA82**

### Lighting and Electrical

- Provide appropriate mix of color correct ambient and task lighting **EA84**
- Install energy-efficient electric lighting **EA85**
- Provide daylighting **EA83**
- Manage phantom loads **EA98**

### Floors and Flooring Products

- Install appropriate finish flooring in basements **EA181**
- Choose hard-surface flooring **IEQ180**
- Avoid carpeting in high moisture areas **IEQ179**
- Use area rugs instead of wall-to-wall carpeting **IEQ182**

### Wall and Ceiling

- Use non-paper-faced gypsum board in moist areas **IEQ183**
- Install environmentally preferable interior sheathing **MR126**
- Limit use of wallcoverings in high moisture areas **IEQ184**
- Use appropriate sheens for paints and finishes **MR130**
- Use low- or zero-VOC interior paints and finishes **IEQ185**
- Use low- or zero-VOC construction adhesives, caulking, and sealants **IEQ187**

### Furniture and Fittings

- Evaluate use of cabinetry and furniture made from particleboard or MDF **MR145**
- Choose furniture and fittings that will not absorb moisture **IEQ188**
- Avoid fully upholstered furniture where moisture may be a problem **IEQ190**
- Minimize use of plush and porous materials **IEQ191**
- Select materials that are easy to clean **MR156**

### Use

- Be attentive to chemicals that might be stored in close proximity to a finished basement room **IEQ198**
- Use environmentally preferable cleaning materials and strategies **IEQ196**
- Store all toxic chemicals far away from living space **IEQ197**
- Educate homeowner for green living **EA103, EA104, EA105**

# case study

**Location:** Sandy Springs, Georgia  
**Homeowners:** Carol Anne and Richard Hendrix  
**Performance Contractor:** Matt Hoots, The Hoots Group, Inc.  
**Area affected:** 2,100 ft<sup>2</sup>

*“Any time we are asked to design and build out a basement we require that moisture control measures be specified and designed into the plans. It is very costly to have to come back at a later date to remediate mold or take care of a foundation leak.” – Matt Hoots*



basement before

## Overview and Scope

Carol Anne and Richard Hendrix wanted to take advantage of their unfinished basement to better accommodate their three teenagers and visits from their large extended family. The new finished basement includes a bathroom, two bedrooms, a media room, and a kitchenette. The team's focus on high performance provided the Hendrix family with a dry, healthy, and durable finished space that requires minimal additional heating and cooling. Certified as an EarthCraft Renovation, this project achieved 186 points in the system, exceeding the 100–160 points required.

## Design Approach

The family wanted the new space—as well as the rest of the home—to be energy-efficient, dry, and free of mold and drafts. To achieve these goals cost effectively required insulating and air sealing throughout the house before basement renovation began, and addressing moisture issues before any finish work was done in the basement. Sound dampening separated basement activity from quieter spaces upstairs.

## Team and Process

The Hoots Home Performance division was involved from the very beginning in planning and implementing efficiency improvements, including spraying foam insulation in the attic roof before work began in the basement. These efficiency improvements, along with switching from a single-zone HVAC system to a four-zone system, and from a fixed to a variable air volume (VAV) air handler, made it possible for the new dual-fuel heat pump to have only a slightly larger capacity than the furnace and air-conditioning units it replaced. Before framing and finishing the basement, the team installed reinforced plastic sheeting on below-grade walls to act as a vapor barrier and to



direct water to a perimeter drain. After the drain system and wall framing were completed, they filled the walls and floor with spray foam insulation. The two crawl spaces were also encapsulated using reinforced plastic sheeting sealed at all seams, and caulked to the foundation walls, to create a complete and continuous vapor barrier. R-8 rigid-foam insulation was added to any exposed spaces without framing.

*“When remodeling a space and bringing it up to, or exceeding, the code in that area of the house, consider looking at the house as a whole. If you upgrade the HVAC and insulation at the same time, the homeowner can reap the benefit of a better balanced house by maximizing their comfort and the home's energy efficiency.”*

– Matt Hoots



Before and after



*“I wanted the boys to have an inviting area that didn’t feel like a basement. Any time you have a basement, there is a chance of it being damp. They sealed everything, including the storage areas that weren’t remodeled, so it won’t be damp and moldy.”* – Carol Anne Hendrix



Before and after



## Finance

Recognizing that they would reap long- and short-term savings, the homeowners agreed to spend a significant amount on tightening the house envelope to reduce heating and cooling loads. Doing so allowed them to significantly reduce the size of the new heating and cooling system so that the total cost of both the efficiency improvements and the mechanical system was equivalent to what an additional system would have cost.

## Lessons and Trade-offs

This project shows both how increased collaboration can engender innovative solutions, and how lack of communication can result in missed opportunities; everyone knew how the efficiency improvements would lower heating and cooling requirements, but the team missed the opportunity to use more material-efficient framing because the renovation manager purchased materials before the rest of the team could suggest alternatives. Also, there were things that nobody thought to consider. For instance, water pipes that previously went unnoticed in the unfinished space created a noise disturbance in the new bedroom.

## By System

### Building Envelope

- Air infiltration in the house reduced by 40%
- Low-e, double-glazed windows
- Band joist between the basement and first floors air sealed and insulated to R-19
- Crawl space walls air sealed and insulated to R-8
- Concrete basement walls air sealed and insulated to R-8
- Framed walls to R-13
- Attic roof insulated to R-19 and all attic vents sealed
- 12-mil reinforced plastic sheeting installed for vapor barrier in crawl spaces and basement, directing water to a perimeter drain pipe with two cleanouts
- Borate-treated sill plates prevent termite damage

### HVAC

- Multi-zone heating and cooling system, with one zone specifically designated for basement
- Variable air volume (VAV) air handler
- Supplies and returns in each room for balanced air flow
- High-efficiency air filter
- New high-efficiency, sealed combustion, dual-fuel heat pump replaced the approximately 20-year-old low-efficiency furnace and air conditioner, providing 14 SEER (air conditioning), 8.5 HSPF (heat pump heating), and 96 AFUE (furnace heating) efficiencies
- Additional space conditioned using one air handler
- Low-noise bath exhaust fan, with rigid metal ductwork, vented to the outside
- New high-efficiency water heaters added to exterior of house for better combustion gas venting

### Plumbing

- Low-flow fixtures

### Lighting

- Fluorescent fixtures

### Appliances

- Energy Star refrigerator

### Use

- Energy operations orientation and binder provided to homeowner



# Home Performance



Home performance is a special type of remodeling project in which a single private- or public-agency sponsored contractor improves the overall energy performance of a home without intensive or extensive modification to the home. A home performance project is one for which the contractor approaches home energy improvement with a whole-house systems approach, one that integrates energy efficiency with combustion safety, moisture management, ventilation strategies, and overall building durability. A whole-house systems approach to home performance generally includes a battery of pre- and post-diagnostics, covered in detail in the project strategy list.

Since by definition a home performance project does not involve any design work, the pre-design issues are actually pre-work issues that must be considered if home performance is to result in whole-house systems improvement. The questions in the Integrated Pre-work issues form the basis for an assessment protocol that can guide home performance work.



# Integrated Pre-Work Issues

## Feasibility

### Is the home “improvable?”

Some homes may simply not be worth the energy-efficiency improvements, or at least not without certain remedial work first. A home may have structural deficiencies or serious site or plumbing issues that are beyond the scope of the performance contractor.

## Existing Problems

### What existing performance problems will need to be addressed before or during the home performance upgrade?

Mold in a bathroom without an operable window or exhaust fan, clogged downspouts dumping rainwater right on the foundation wall, old window sashes stuck in something less than a fully closed position—all of these pre-conditions need to be assessed and addressed to make the home performance project successful.

## Unintended Consequences

### What performance problems may be initiated or exacerbated as the result of the home improvement upgrade?

A window leak that has been drying out for years due to heat loss quickly leads to rot after the wall in which the window is installed is weatherized (filled with blown-in cavity insulation and the window weatherstripped/airsealed). A natural draft or atmospherically-ventilated gas water heater that drafted just fine before the home performance project now backdrafts because the pressure regime of the home has been changed dramatically. A whole-house systems approach to home performance makes use of pre- and post-diagnostics to evaluate building performance changes.

## Changing Behavior

### What existing performance problems are not directly related to the building but are directly related to occupant habits or behavior?

All sorts of occupant behavior can inadvertently circumvent home performance improvements including lack of use of exhaust fans, windows open for ventilation during the heating season, incandescent lights left on 24/7, cord wood stored in the basement. An important part of any home performance project is occupant education that enhances rather than erodes building performance.

# strategies



## Project Scope

### Includes:

- Energy testing
- Combustion safety testing
- Insulation
- Air sealing
- HVAC
- Radon testing
- Moisture management (primarily evaluation)
- Homeowner education
- Lighting

### Does not include:

- “Wet” rooms – kitchen, bath or laundry - See Kitchen and Bathroom
- Basement (new or retrofit) – See Basement
- Interior finishes – See Kitchen, Bedroom
- Landscaping and outdoor water use – See Outdoor Living
- Appliances and equipment – See Deep Energy Retrofit
- Renewable energy – See Deep Energy Retrofit



© COAD

## Strategies by Building System

### General Design and Construction Strategies

- Ensure durability **IDP1**
- Conduct a home performance audit **IDP2**
- Manage noise **IDP4**
- Design with air quality in mind **IDP5**
- Design for a sustainable lifestyle **IDP6**
- Manage construction and demolition waste **MR107**
- Control the spread of pollutants **IEQ158**
- Test for, and appropriately handle, hazardous materials **IEQ159**
- Conduct lead-safe work **IEQ160**
- Provide appropriate insect control **IDP23**
- Assess vapor profile of new assemblies **IDP25**
- Use computer modeling to determine heating and cooling loads **EA45**

### Building Envelope

- Optimize energy performance **EA48**
- Install attic insulation **EA49**
- Consider a radiant barrier in the attic **EA50**
- Conduct blower door test (before and after) **EA51**
- Conduct room-to-room pressurization testing **EA52**
- Conduct infrared imaging (before and after) **EA53**
- Complete thermal bypass inspection/resolution **EA54**
- Airseal/insulate rim joists **EA55**
- Upgrade existing windows **EA56**
- Upgrade existing exterior door **EA57**
- Weatherstrip doors and windows **EA58**
- Use high-recycled-content, formaldehyde-free insulation **MR117**
- Use low- or zero-VOC construction adhesives, caulking, and sealants **IEQ187**
- Use FSC-certified wood **MR118**

### HVAC

- Conduct duct tightness test (before and after) in homes with forced air systems **EA68**
- Install programmable thermostats **EA67**
- Properly commission new (or tune existing) HVAC systems **EA69**
- Properly seal and insulate HVAC distribution system **EA70**
- Make sure ducting is clean **EA71**
- Install CO and smoke alarms **IEQ164**

### Plumbing

- Choose a high-efficiency water heater **EA79**
- Insulate hot water pipes **EA81**
- Insulate water heater **EA80**

### Lighting and Electrical

- Design for effective and color correct ambient and task lighting **EA84**
- Install energy-efficient electric lighting **EA85**
- Manage phantom loads **EA98**

### Use

- Educate homeowner for green living **EA103, EA104, EA105**



# case study

**Location:** Castro Valley, California  
**Homeowners:** Kathy and Mike Manus  
**General Contractor:** Sustainable Spaces Inc.  
**Area affected:** 1,800 ft<sup>2</sup>

*“We did not want to waste money on hit-and-miss home repairs. Sustainable Spaces’ professionals analyzed our home and designed a plan that prioritized solutions to meet our needs while increasing our home’s overall energy efficiency. We now have a home that is warm and cozy.”*

– Kathy Manus



Before –  
low-efficiency, natural  
draft water heater

## Overview and Scope

The Manus’ home suffered from a variety of common symptoms that included an uneven heating system that left them uncomfortable on cold winter days, but also high energy costs relative to their house’s reasonable size and temperate San Francisco climate. Prior to the renovation, monthly energy bills commonly averaged \$350, even with the thermostat below 65°F on cold days. By setting priorities based on an initial comprehensive home-performance evaluation, Sustainable Spaces created a phased plan to maximize the client’s return on investment in dollars as well as in health and comfort. The Manus’ family now has a comfortable home with clean air and significantly lower energy bills.

## Design Approach

In order to address the homeowners’ goals and concerns, in a practical, cost-effective manner, Sustainable Spaces started with a detailed home performance inspection to evaluate the home as a system, including insulation, outdoor air infiltration, duct leakage, heating and cooling load and systems, moisture issues, water heating, lighting, appliances, and general durability. Based on these findings, the team prescribed a list of priorities targeting those issues that resulted in uncomfortable rooms, unhealthy air, and wasted energy. The project started with building fundamentals including envelope sealing and weatherization, duct system redesign and replacement, additional attic insulation, and a lighting retrofit. By first reducing the home’s energy load, they significantly reduced the size of major system improvements, including a new hydronic air handler and air filtration system, a new high-efficiency hot water heater (now the home’s primary heat source for domestic hot water and space heating), and a demand recirculation pump for convenience and water conservation. Using energy modeling software to determine the amount and balance of airflow to each room and to design ductwork to ensure that the system is properly balanced, they took the guesswork out of making the home comfortable and efficient. Finally, after completing remediation, every step was tested and commissioned to ensure the home performed as designed.



After – power vented high-efficiency water heater

## Team and Process

Sustainable Spaces takes a holistic approach, evaluating a home’s performance as a dynamic, interdependent system in order to identify specific steps to improve indoor air quality, comfort and energy efficiency, while always keeping the homeowners’ objectives in mind. A licensed general and solar contractor specializing in home testing and building performance remediation for existing homes, Sustainable Spaces sought first to understand the clients’ concerns and behaviors. Combined with quantitative data about their home’s performance, this allowed Sustainable Spaces to tailor solutions to the client’s goals, budgets, and priorities while creating an efficient, comfortable, and healthy green home.





Home performance audit: testing water heater draft

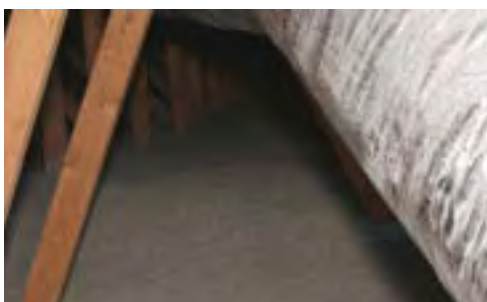


Before – duct leakage



Before – bad ducting

*“Our goal is to work with our clients to create a roadmap for improving their home’s performance. We recognize that not everyone can make their home 100% green and zero energy in the first pass. By creating a comprehensive plan, our clients can start down the path towards sustainability and see real results on almost any budget.”* – Matt Golden, CEO, Sustainable Spaces



After – attic reinsulated with cellulose

## Finance

Sustainable Spaces created a roadmap for this project based on multiple phases, focusing first on those items with the biggest impact but from within the framework of the clients' long term goals. A phased approach fitted the Manus' budget, while achieving measurable results. By focusing improvements on air quality, comfort, and environmental impact, in addition to energy savings, Sustainable Spaces was able to get buy-in from the client for more integrated solutions.

## Lessons and Trade-offs

The homeowners originally wanted a tankless hot water heater; however their home performance inspector recognized that large gas bills, and poor comfort and indoor air quality were their underlying concerns. While tankless water heaters can be a good fit in some situations, a systems-based approach revealed that a high-efficiency power-vented storage water heater was more economical and appropriate for the new combined domestic hot water and space-conditioning system.

## By System

### General Design and Construction

- Engineered the home for balanced, comfortable heating
- Improved air quality through duct and envelope sealing
- Extracted airborne pollutants with high efficiency filtration
- Reduced energy consumption through heating and electrical load reduction

### Building Envelope

- Blower door test to identify amount of air leakage; building envelope sealing to achieve compliance with ASHRAE 62.2 requirement for hourly fresh air exchange
- Replaced non-insulation contact rated can lights with airtight insulation contact can lights
- Installed 12" of blown-in cellulose in attic to achieve R-38 or greater insulation

### HVAC

- Duct blaster test to identify amount of duct leakage; Before: 360 CFM25, After: 76 CFM25; leakage reduction of 79%
- Total heating load reduced from 50,600 BTU to 38,200 BTU, a decrease of 25%
- Replaced ducts with properly designed and installed R-6 wireflex duct work
- System engineered based on ACCA Manual J load calculations, Manual D to design ducts, and Manual S to size equipment
- System commissioned to ensure airtight ducts, proper static pressure, and proper room-by-room airflow
- Replaced existing furnace with a properly sized hydronic air handler
- Energy Star programmable thermostat
- High-efficiency air filtration system
- New high-efficiency, fast-recovery water heater with side taps for hydronic heating
- Insulated hot water pipes
- Demand recirculation pump to conserve water and energy, and reduce time for hot water delivery

### Use

- Instructed homeowners on proper usage of new equipment
- Programmed thermostat to balance comfort and efficiency

# Major Addition

## Green From the Start

Just a 'Green From The Start' reminder about the home performance audit and interior space planning; they are particularly important for this project.

In this guide, a major addition is any addition of living or conditioned space that requires additional foundation, or that adds a floor between the attic and the finished floor below, or adds a floor between the first floor and the foundation. In any of these cases, there are major design and construction decisions that have significant impact on the overall resource and energy efficiency of the home. Some of the pre-design issues may seem pretty basic to the experienced remodeling professional, but each of these questions is intended to challenge underlying assumptions that either the professional, or almost certainly the client, bring to the pre-design phase of the major addition project.



# Integrated Pre-Design Issues

## Reconfiguring Existing Space vs. an Addition

### Is it really necessary to add square footage to the home?

The greenest option is usually to adapt existing space in a home to new needs instead of adding new space, so this option should be carefully evaluated before moving ahead with an addition.

## Size Matters

### Is the new space no bigger than needed?

Assuming that all of the possibilities to reconfigure existing space to meet the client's needs have been exhausted and an addition has been identified as the way to go, it can be tough to resist the temptation to "add big," especially since the client may only have one chance to do a major addition on a home. But perhaps the single largest driver of environmental impact is the total square feet of the space—both in terms of material use and operating energy. Time spent up-front ensuring that the addition is as space-efficient as possible can pay big dividends in dollars saved by the client, level of quality in finishing details and materials, and reduced impact to the environment.

## Expansion Options

### Have all three of the options been considered: new-footprint addition, tuck-under floor addition, or "raise-the-cap" added floor?

Certainly this decision is driven by configuration of the existing home, lot size and configuration, and vernacular architecture. But depending on just what functions the client requires or desires of the new space, each may have merit and one may have environmental advantage in terms of improved energy performance, greater resource efficiency, or increased durability.

## Flexibility of New Space

### Can the new space be used in a variety of ways over time to meet the client's changing needs or meet the needs of subsequent owners?

The layout of an addition—including wiring, accessibility, and window placement—all can be designed to make the new space more easily reconfigured or re-purposed over time. Ideas to consider range from making all interior partitions non-load-bearing to incorporating universal design for aging in place. While it's important to design first for existing conditions, future environmental impacts and financial costs of renovation can be minimized by making spaces flexible over time.

## Stand-alone Passive

### Can the new space heat and cool itself?

The ability of a space to maintain acceptable thermal comfort is a function of building envelope performance, orientation, site characteristics that influence solar gain, and climate. Downsizing or even eliminating heating and cooling systems can save on both the capital and operating costs of the addition and have big environmental savings as well. With energy-efficient design, it might make more sense to provide small space-heating and room air conditioning rather than extending distribution ducts or

pipes from existing central systems. An experienced professional engineer or energy consultant and computer modeling are often needed to achieve these goals.

## Getting the Storage-to-Living Space Ratio Right

### Is the new space designed to spend energy keeping people, or things, comfortable?

Let's face it—most people have an awful lot of "stuff." While this phenomenon in and of itself poses some green living questions, it is not unusual for up to 50% of new space to be unnecessarily configured as fully conditioned storage space. Design spaces with adequate storage, but configure spaces so that only people and temperature-sensitive "stuff" end up being conditioned.

This can take some real "face time" with the client, teasing out patterns of use and prioritizing both activities and possessions, but the pay-off can be significant in optimized space utilization.

## A Durable Building Envelope

### Will the new addition last hundreds of years?

This is mostly about moisture management but could include resistance to other stressors, such as insects, sunlight, or wildfire. Care should be taken to evaluate how the addition shelters or increases exposure of the existing structure to rain, snow loading, wind, etc. A low-slope valley that was handling rain and snow marginally well may fail if the addition adds more rain or snow to the challenged valley.

## Type of Foundation

### There are four types of foundation systems—full basement, crawlspace, piers, and slab-on-grade. Upon what criteria will one be chosen?

In addition to conditions such as climate, site, soil, and the existing structure's foundation system, there are resource-efficiency issues to consider. A full basement involves the most material and site disturbance, a pier foundation the least of both. An un-vented crawlspace can increase the total conditioned space, but may be more energy-efficient overall and much less prone to moisture problems than a vented crawlspace. Make the selection of the addition's foundation system a conscious decision, based on a full evaluation of which system best meets the needs of the client and the environmental impact of each system.



## Project Scope

### Includes:

- Passive solar design considerations
- Foundation
- High performance building envelope
- Advanced framing
- Integration/analysis of mechanical needs of new and existing space
- Lighting and electrical

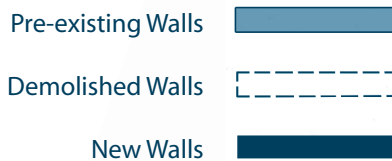
### Does not include:

- “Wet” rooms—kitchen, bath or laundry – See Kitchen and Bathroom
- Basement (new or retrofit) – See Basement
- Interior walls - See Gut Rehab
- Interior wall finishes –See Bedroom, Living & Working
- Furniture and Fittings – See Bedroom and Living & Working
- Plumbing Distribution – See Gut Rehab
- Appliances and Equipment – See Deep Energy Retrofit
- Renewable energy – See Deep Energy Retrofit
- Landscaping and outdoor water use – See Outdoor Living

## Strategies by Building System

### General Design and Construction Strategies

- Ensure durability **IDP1**
- Conduct a home performance audit **IDP2**
- Optimize energy performance during design **IDP3**
- Manage noise **IDP4**
- Design with air quality in mind **IDP5**
- Design for a sustainable lifestyle **IDP6**
- Employ universal design **IDP7**
- Optimize interior layout **IDP8**
- Design in sheltered entryway **IDP9**
- Design for storage **IDP10**
- Configure for solar access **EA100**
- Use computer modeling to determine heating and cooling loads **EA45**
- Evaluate different heat distribution options **EA46**
- Install track-off mats at exterior doors **IEQ161**
- Assess vapor profile of new assemblies **IDP25**
- Include capillary break between all concrete and sill plates **IDP22**
- Control the spread of pollutants **IEQ158**
- Manage construction and demolition waste **MR107**





### Site

- Minimize site disturbance **SS29**
- Maintain adequate slope and drainage away from building **IDP13**
- Make use of trees and landscaping to reduce cooling loads **SS30**
- Modify landscaping to provide solar access **SS31**
- Minimize contiguous impervious surfaces and facilitate infiltration **SS32**
- Design landscape features to minimize heat island effects **IDP17**
- Use landscape features to shield the house **SS36**
- Use site-chipped/ground clean wood waste as erosion control **SS39**

### Foundation

- Provide proper moisture control at footings, slab perimeter, and foundation walls **IDP19**
- Install a radon mitigation system **IEQ163**
- Provide appropriate insect control **IDP23**
- Use biobased form-release agent or permanent forms **MR115**
- Use fly ash in concrete **MR114**
- Insulate floor slab and foundation walls **EA47**
- Install CO and smoke alarms **IEQ164**

### Building Envelope

- Provide proper moisture management strategies **IDP24**
- Minimize material use with advanced framing or SIP construction **MR116**
- Use FSC-certified wood **MR118**
- Optimize energy performance **EA48, EA50, EA51, EA52, EA53, EA54, EA55**
- Use high-recycled-content, formaldehyde-free insulation **MR117**
- Use high-performance windows **EA59**
- Specify different glazings for different window orientations **EA60**
- Provide durable, reflective roof **MR120**
- Install awnings or other exterior window shading system **EA62**
- Install a durable wall cladding **MR119**

### HVAC

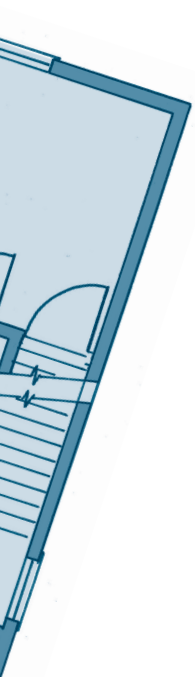
- Evaluate different heat distribution options **EA46**
- Use ACCA Manual J, S, and D in mechanical system design **EA63**
- Consider alternatives to conventional refrigerant-cycle air conditioning **EA65**
- Provide appropriate controls and zoning for HVAC **EA64**
- Select high-efficiency HVAC equipment **EA66**
- Install programmable thermostats **EA67**
- Make sure ducting is clean **EA71**
- Install ceiling fan **EA76**
- Properly commission new (or tune existing) HVAC systems **EA69**

### Lighting and Electrical

- Plan for the future with wiring and cabling needs **MR121**
- Provide daylighting **EA83**
- Use prudent avoidance with electromagnetic fields **IEQ177**
- Provide appropriate mix for color correct ambient and task lighting **EA84**
- Install energy-efficient electric lighting **EA85**
- Manage phantom loads **EA98**
- Provide controllable interior shading **IEQ178**

### Use

- Educate homeowner for green living **EA103, EA104, EA105**



# case study

**Location:** Ann Arbor, Michigan  
**Homeowners:** Steve and Lynda Norton  
**Architect:** Dawn Zuber, Studio Z, NARI member  
**Interior Designer:** Kimberly Weder, Kimberly Weder Designs  
**Contractor:** Dave Klein, David Klein Construction, Inc.  
**Area affected:** 674 ft<sup>2</sup> added

*“When adding to a house built so long ago, it is a real challenge to build an addition so it is energy-efficient—and then not show that it is an addition.”* – Dawn Zuber



house before

## Overview and Scope

A modest 674 square-foot addition was added to this 1,615 square-foot 1920s Craftsman-style house to make it more functional for Steve and Lynda Norton and their two children, who had lived in the neighborhood for 20 years. With plans to remain in their house for many more years to come, the couple wanted an addition that would fit their traditional neighborhood and not dwarf their neighbors’ homes. While the house is not filled with popular green products, the family’s decision to make a small addition on a small house with a focus on energy efficiency and durability significantly reduces the environmental impact of the project.

## Design Approach

The couple wanted a master bedroom suite, a new family room to supplement the existing tiny living room, and a bit more space including a separate bathroom for the two growing kids. In order to make the most of the home’s relatively small footprint, the team carefully reconfigured much of the existing space and installed a variety of built-in features. Built-in desks and shelving were added to many of the rooms and a bed with integral storage was built-in to the new master bedroom. The existing second floor bathroom was reconfigured for the children and guests, and the existing master bedroom became a guest bedroom, with a portion of it adapted as a hallway to the new master suite. The existing front porch was enlarged to provide a place for the family to enjoy the weather and interact with the neighbors. The high-velocity air conditioning and radiant floor heating systems were carefully extended so that the existing boiler and air-conditioning equipment could provide for new as well as existing loads. The roof of the addition was designed so that the raised heel trusses, used to improve energy efficiency, would align with the existing roof, despite the differing construction.



## Team and Process

The team’s goal was to make the small space pleasant and energy-efficient, using durable low-maintenance finishes. The architect, contractor, and interior designer had all worked with each other before, and this made it easier to pursue alternative construction techniques. While the architect took the lead on defining the space, having the interior designer involved early on allowed her to help determine an optimally functional layout.

*“If you want to have something you’ll really feel good about for a long time you need to spend a bit more than you planned, to do those things that maybe nobody will ever see but that will extend the life and soundness of your home.”* –Steve Norton



Office during construction

*“There are a lot of ways to interpret what is green. To me it is so frustrating to see people move into enormous McMansions and have rooms they don’t use. I remind people you’ve got to heat and cool and furnish that space.”*

– Dawn Zuber



Reconfigured living room



Reconfigured master bath



Built-in cabinetry and daylit work station

## Finance

The family factored in long-term costs and effort as much as possible, recognizing that any increased first costs for energy efficiency and more durable products with lower maintenance requirements would be paid back in reduced costs and hassle over time. Money that might otherwise have been spent building a larger addition instead went into quality features like the custom built-ins throughout the house.

## Lessons and Trade-offs

Especially with new construction approaches, overseeing the details of implementation is critical. On a site visit the architect noticed that the contractors had rerouted the ducting for the passive radon remediation system, effectively eliminating the stack effect that would pull the radon out; this was explained to the contractors and corrected. The homeowners had a lot of decisions to make and often not enough time to make them. Steve found it hard to get good information to compare the long-term energy costs of different hot water energy systems. In the end they decided to take the hot water off of the existing boiler, but he would have liked to have been more sure of the decision. They made other trade-offs such as choosing fiber-reinforced cementitious siding and vinyl trim with the thought that the long life and low maintenance requirements of the product would overcome its environmental downsides.

## By System

### Site

- Wraparound porch extends three-season living space

### Building Envelope

- Minimally sized addition
- Engineered I-joists to reduce framing material use
- Two-stud corners for better corner insulation
- Raised heel trusses
- Cellulose insulation
- Low-e, energy-efficient new and replacement windows
- Passive radon abatement system
- Durable fiber-reinforced cementitious siding

### HVAC

- Radiant floor heating system extended with existing high-efficiency boiler
- Air-conditioning ducting extended with existing system

### Lighting

- Daylighting from windows, skylights, and light tubes

### Plumbing

- PEX tubing
- Low-flow toilets

### Furnishings and Finishes

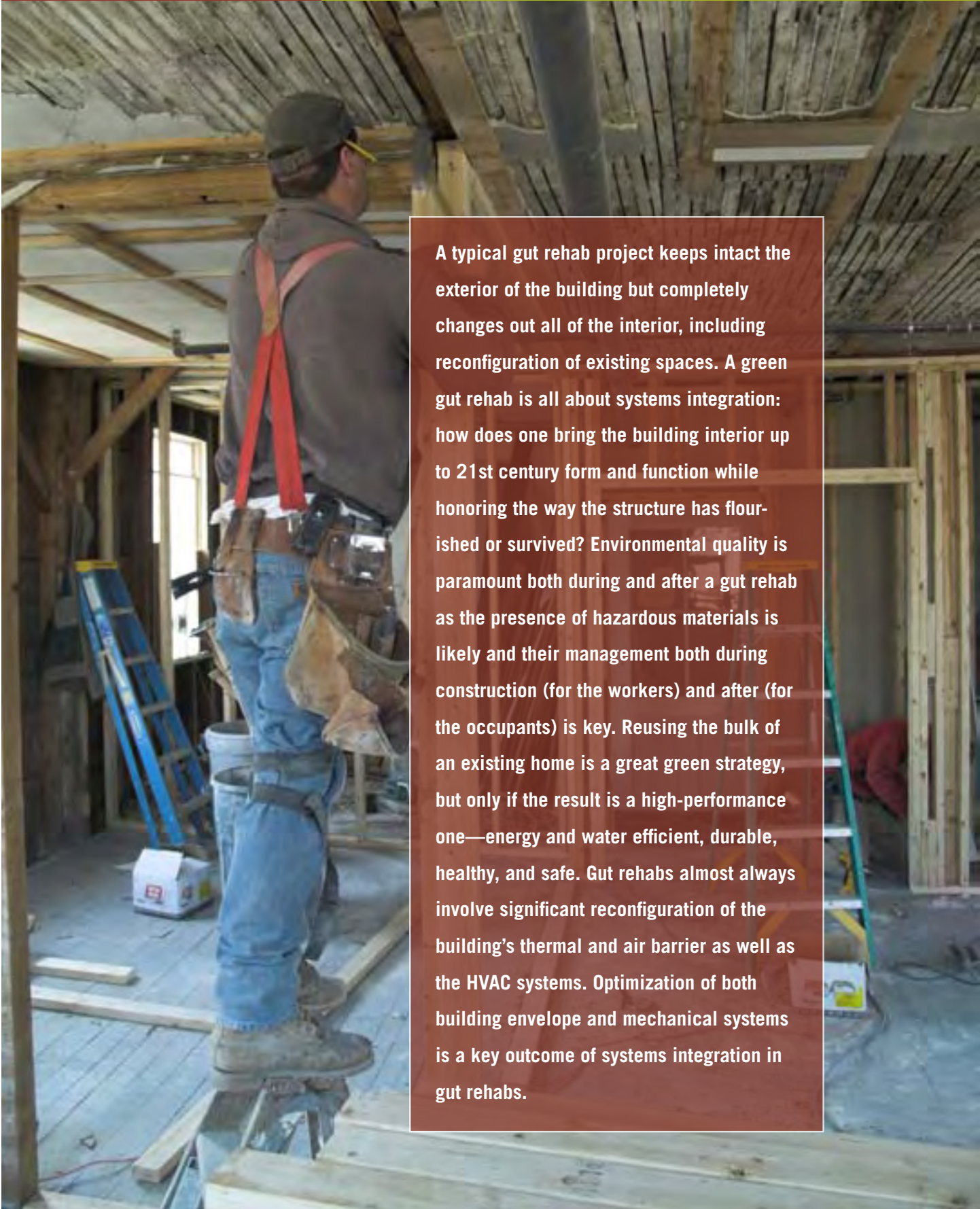
- Built-in desks, shelving, and cabinetry to optimize use of space
- Durable wet-plaster finishes
- Durable composite decking for the porch



# Gut Rehab

## Green From the Start

Just a 'Green From The Start' reminder about the home performance audit and interior space planning; they are particularly important for this project.



A typical gut rehab project keeps intact the exterior of the building but completely changes out all of the interior, including reconfiguration of existing spaces. A green gut rehab is all about systems integration: how does one bring the building interior up to 21st century form and function while honoring the way the structure has flourished or survived? Environmental quality is paramount both during and after a gut rehab as the presence of hazardous materials is likely and their management both during construction (for the workers) and after (for the occupants) is key. Reusing the bulk of an existing home is a great green strategy, but only if the result is a high-performance one—energy and water efficient, durable, healthy, and safe. Gut rehabs almost always involve significant reconfiguration of the building's thermal and air barrier as well as the HVAC systems. Optimization of both building envelope and mechanical systems is a key outcome of systems integration in gut rehabs.



# Integrated Pre-Design Issues

## Opportunity for Salvage/Deconstruction/Historic Preservation or Realignment

### What elements of existing design or materials have value and can be integrated into the new design of the interior space(s)?

Especially with buildings that have many “layers” from previous renovation projects, it can be easy to miss “gems” of the original design and layout or materials that can be brought back to the “surface” and incorporated into some aspect of the new design. Certainly not all old or older buildings present the opportunity for reviving historic architectural features, materials, or layouts but an understanding of the “layers and lives” of older buildings is often an initial design step easy to skip.

A “behind-the-walls” exploration of both the building and whatever architectural documents that are available may be required to determine what, if any, aspects of the original design or hidden materials may impart special value to the building and its new design.

## Existing Hazards

### What might the building contain that requires special handling, either in terms of safe removal or complete encapsulation?

The list of potentially hazardous materials that can be in, on, or even under older homes is dishearteningly lengthy—lead, mold, asbestos, persistent pesticides, coal dust, creosote, etc. Care must be taken to determine whether or not these substances are a part of the project, and if so, are they best handled with professional removal or complete encapsulation?

## Existing Energy/Moisture Balance or Conditions

### How might increases in the energy efficiency of the building envelope shift existing moisture loads from an equilibrium to a moisture problem?

It is common good practice to eliminate the obvious water leaks in roofs, walls, and foundations before gut rehabbing any structure. But what about the difficult-to-detect, smaller leaks that a drafty, energy-intensive older home may have that turn into a moisture problem when the home is made much more airtight and the building envelope fully insulated? Or, masonry systems (concrete block, structural brick wythes, mortared stone veneers) that absorbed and managed a moisture load just fine when uninsulated and air-leaky but fail, or cause connected building elements to fail, when incorporated into an energy-efficient new configuration?

## Systems Integration—Mechanical Systems, Interior Layout, Structural Framing

### How can new interior layouts, structural framing, and HVAC distribution systems work together to improve rather than degrade thermal comfort and space-conditioning efficiency?

Many, if not most, gut rehabs provide the opportunity for integration of mechanical systems—particularly plumbing and space conditioning—into new layouts and new/existing

structural framing. The performance of the best water heater or boiler can be significantly diminished by inefficient ducting or piping layouts. And the opening up of floor plans so common in today’s gut rehabs can make efficient mechanical distribution much more challenging.

The orientation of floor framing, dimensions of interior walls and chases, the location of “wet” rooms (rooms requiring domestic plumbing: laundry, baths, kitchen), and the location of power units can all combine to help or hurt the ultimate energy performance of the new space. Particularly in terms of interior layout, consider layouts that permit a plumbing core by “backing or stacking” wet rooms, and boosting the energy performance of the building envelope so that centralized and simplified HVAC distribution can replace perimeter distribution.

## Eliminating Mechanical Systems

### Can the building envelope be improved enough to eliminate centralized or active space conditioning systems?

Depending on climate, one way of breaking through the first cost barrier of dramatic energy improvements is to boost the building envelope performance to such a degree that either all active forms of space conditioning can be eliminated or all centralized space conditioning can be replaced with spot/task heating and cooling. Eliminating central cooling and heating equipment and the distribution systems they require frees up thousands of dollars that may be needed for just such building envelope upgrades.

## The Impact of Climate

### What changes to building envelope and HVAC performance work best for the climate of the particular site?

A gut rehab of a two-story home with a basement in Ohio, a split-level coastal home on piers on the coast of Southern California, and a ranch slab-on-grade home in Florida will all involve very different optimal combinations of building envelope and HVAC system changes. The importance of the glazing area and thermal properties of windows varies, the benefit from higher levels of wall and roof insulation is quite different, and the impact of state-of-the-art space heating and space cooling equipment will range widely, all based on site and climate. The best way to analyze the options is to use an energy modeling tool, exploring how various changes in building envelope and HVAC performance optimize the remodeled home’s performance.

## Certification

### Is the client seeking LEED for Homes certification?

Because of the extensive alterations involved, a gut rehab is the only residential remodeling project that is included in LEED for Homes rating system. In LEED for Homes, a gut rehab is held to the same standard as new construction. Similarly, because it is so extensive, a gut rehab may qualify for Energy Star Homes or one of the many local and regional green building programs around the country.

# strategies



## Project Scope

### Includes:

- Comprehensive existing hazardous materials management (protection for workers and future occupants)
- Comprehensive building envelope upgrade/redesign (from framing cavity to interior)
- Vapor profile (determination of drying potential/direction)
- Bulk/capillary water management
- Structural loading
- Layout reconfiguration
- Interior walls
- Plumbing distribution
- Mechanical distribution
- Lighting and Electrical

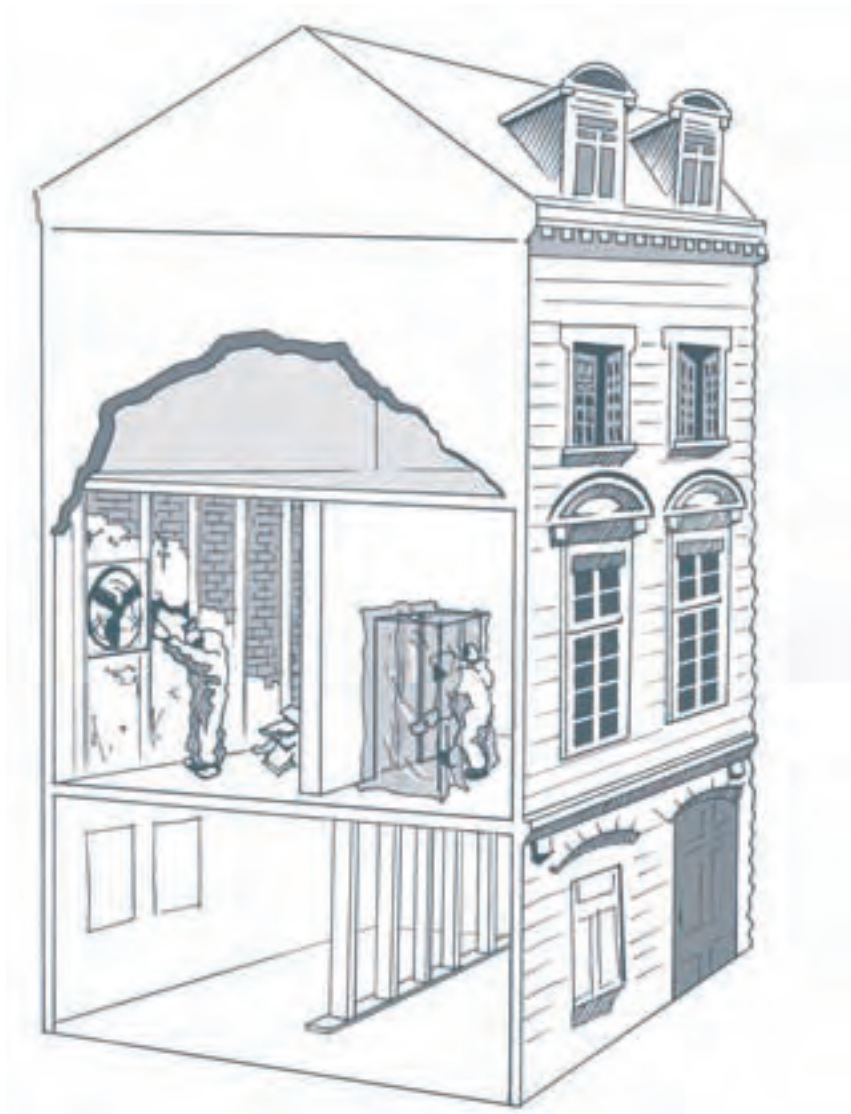
### Does not include:

- “Wet” rooms – kitchen, bath or laundry - See Kitchen and Bathroom
- Basement (new or retrofit) – See Basement
- Interior finishes – See Bedroom, Living & Working
- Landscaping and outdoor water use – See Outdoor Living
- Appliances and equipment – See Deep Energy Retrofit
- Renewable energy – See Deep Energy Retrofit

## Strategies by Building System

### General Design and Construction Strategies

- Manage construction and demolition waste MR107
- Ensure durability IDP1
- Conduct a home performance audit IDP2
- Optimize energy performance during design IDP3
- Manage noise IDP4
- Design with air quality in mind IDP5
- Design for a sustainable lifestyle IDP6
- Employ universal design IDP7
- Optimize interior layout IDP8
- Design in sheltered entryway IDP9
- Design for storage IDP10
- Assess vapor profile of new assemblies IDP25
- Use computer modeling to determine heating and cooling loads EA45
- Control the spread of pollutants IEQ158
- Test for, and appropriately handle, hazardous materials IEQ159
- Conduct lead-safe work IEQ160
- Install track-off mats at exterior doors IEQ161



### Site

- Minimize site disturbance **SS29**
- Use site-chipped/ground clean wood waste as erosion control **SS39**

### Foundation

- Install a radon mitigation system **IEQ163**
- Install CO and smoke alarms **IEQ164**
- Insulate floor slab and foundation walls **EA47**

### Building Envelope

- Provide proper moisture management strategies **IDP24**
- Assess vapor profile of new assemblies **IDP25**
- Optimize energy performance **EA48, EA50, EA51, EA52, EA53, EA54, EA55**
- Use FSC-certified wood **MR118** or SIP construction **MR116**
- Use high-recycled-content, formaldehyde-free insulation **MR117**
- Upgrade or replace existing windows and doors **EA56, EA57, EA59**
- Specify different window glazings for different orientations **EA60**
- Install awnings or other exterior window shading system **EA62**

### Interior Walls

- Use FSC-certified wood **MR118**
- Install environmentally preferable sheathing **MR126**
- Select environmentally preferable interior doors **MR127**

### HVAC

- Use ACCA Manual J, S, and D in mechanical system design **EA63**
- Evaluate different heat distribution options **EA46**
- Consider alternatives to conventional refrigerant-cycle air conditioning **EA65**
- Provide appropriate controls and zoning for HVAC **EA64**
- Select high-efficiency HVAC equipment **EA66**
- Properly commission new (or tune existing) HVAC systems **EA69**
- Install programmable thermostats **EA67**
- Properly seal and insulate HVAC distribution system **EA70**
- Make sure ducting is clean **EA71**
- Discontinue unconditioned basement or crawl-space ventilation **EA74**
- Avoid ozone-depleting refrigerants **EA75**
- Provide appropriate venting of all combustion-based heating and water heating equipment **IEQ168**

### Plumbing

- Reconfigure plumbing to distribute domestic hot water efficiently **EA77**
- Install on-demand hot water recirculation system **EA78**
- Choose high-efficiency water heater **EA79**
- Insulate water heater **EA80**
- Insulate hot water pipes **EA81**
- Consider the environmental preferability of piping material **MR122**

### Lighting and Electrical

- Plan for the future with wiring and cabling needs **MR121**
- Provide daylighting **EA83**
- Provide appropriate mix of color correct ambient and task lighting **EA84**
- Install energy-efficient electric lighting **EA85**
- Avoid recessed lights in insulated ceilings or use Insulation-Contact fixtures **EA86**
- Provide appropriate indoor lighting controls as needed **EA90**
- Manage phantom loads **EA98**

### Use

- Educate homeowner for green living **EA103, EA104, EA105**

# case study

**Location:** New York City, NY  
**Homeowners:** Alycia and David Basche  
**Design/Build Team:** Robert Politzer, Hanna Purdy, and Nick Moons of GreenStreet Construction, Inc.  
**Area effected:** 3,500 ft<sup>2</sup>

*“I love the expression that in building there’s budget, there’s time, and there’s quality, pick two; and we picked quality and low budget—so we had to let go of time.”* – Alycia Basche



interior before

## Overview and Scope

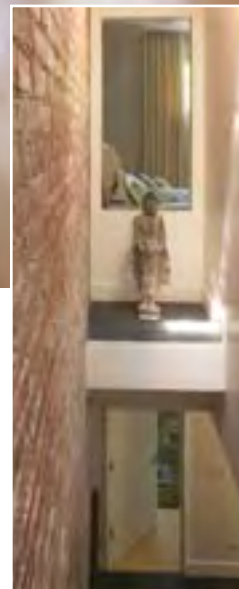
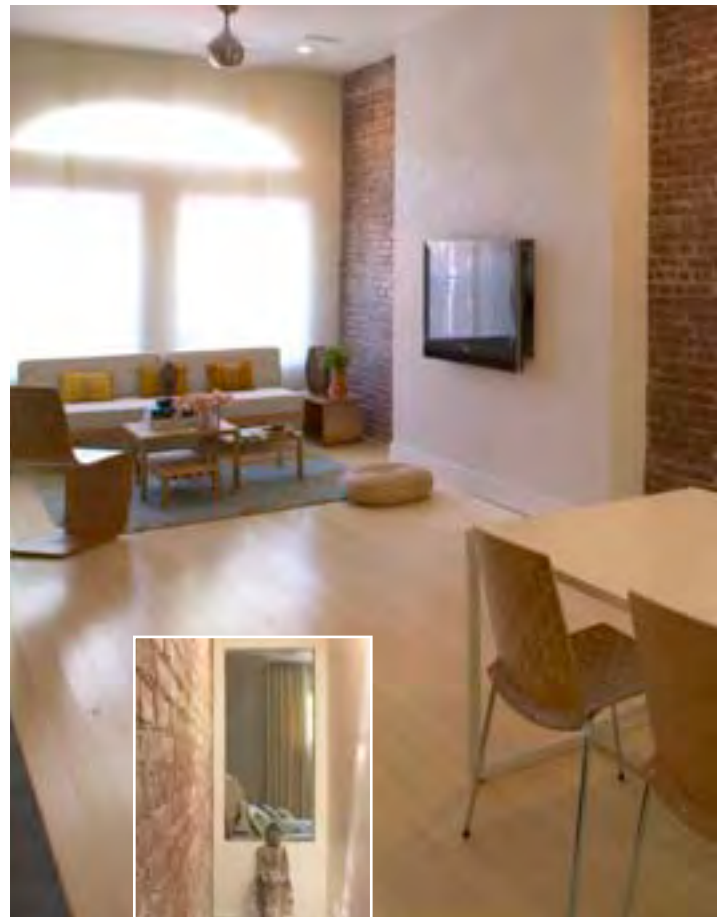
As difficult as it is to become homeowners in New York City’s perpetually tight housing market, Alycia and David finally managed to purchase a brownstone in Harlem. The trashed and stripped structure needed a complete makeover including a new roof, windows, insulated exterior walls, interior walls, and all new HVAC, plumbing, and electrical systems. Despite a tight budget, the experienced green design/build team and actively engaged homeowners created an elegant, daylit townhouse with a spacious kitchen, low-emitting materials, and numerous other green amenities.

## Design Approach

Convinced of the value of building green, and with David having suffered lifelong allergies, the couple was invested in creating a healthy and environmentally friendly home. Both the contracting team and the homeowners accepted building green on a budget as a design challenge. The team viewed the whole process through the lens of environmental impact, carefully considering energy efficiency, indoor air quality, and environmentally friendly materials. In selecting each product, the homeowners took care to ask whether a greener product could be found.

## Team and Process

The design/build team and the homeowners worked closely together throughout the project. David and Alycia researched green products and materials, and did much of the demolition and construction work themselves.



*“We had been impressed by building green and being sustainable, but would we really be able to do it in practice? When we told GreenStreet what we had in mind, they said ‘well that’s what we do.’ They were three points on a triangle: Nick was ‘we can build it;’ Robert was ‘we can build it green and I can explain to you how;’ and Hanna was ‘it’s going to be beautiful.’”* – David Basche





Preserved brownstone front facade

*“Alycia doing so much research and David being onsite every day has kept this project on task. It has really helped us make this project greener for less money.”*

– Hanna Purdy



Main floor under construction (above)  
Remodeled main floor (below)



Remodeled master bath and bedroom



## Finance

The homeowners knew it would be a challenge to tackle this extensive gut-rehab on a budget. How to creatively address budget constraints while achieving their aesthetic and green goals was a major component of the conversation from the start. Their answer to budgetary “surprises” was to pitch in even more of their own labor, rather than compromise on quality. Partly for this reason, the project took two years to complete.

## Lessons and Trade-offs

Like many homeowners on a budget, David and Alycia did the demolition work themselves. Although the structure was filled with moldy drywall and trash, it was free of lead paint and asbestos; improper abatement of these hazards can pose ongoing problems.

## By System

### General Design and Construction Strategies

- 50% Deconstruction and construction waste recycling

### Building Envelope

- Formaldehyde-free batt insulation
- Modular green roof

### Plumbing

- Dual-flush toilets

### HVAC

- Whole-house fan and ducted air-conditioning system
- Kitchen and bathroom exhaust
- Radiant floor heating system throughout
- Flat plate hot water radiator
- High-efficiency hot water and space heating

### Lighting

- Extensive daylighting
- Compact fluorescent lighting
- Automated controls

### Equipment

- Energy Star appliances

### Wall and Ceiling Finishes

- Bamboo and natural slate flooring
- Low volatile organic compounds (VOCs), caulks, paints and adhesives
- Fasteners (not adhesives) to minimize VOCs
- Zero-VOC clay finish made with reclaimed stone, natural pigments, and a soy binder

### Furniture and Fittings

- Recycled content countertop



# Deep Energy Retrofit

## Green From the Start

Just a 'Green From The Start' reminder about the home performance audit and interior space planning; they are particularly important for this project.

A deep energy retrofit is one in which the energy performance of the existing home is radically reduced. Total household energy reductions of 50% to 90% are achieved by addressing all or nearly all loads—space conditioning, hot water, lighting, appliances, and plug load—and sometimes even transportation. Energy reductions of this magnitude require an intensive and extensive systems approach—the inherent relationships among energy, indoor air quality, durability, and thermal comfort must be honored throughout design and construction. Passive solar design and renewable energy systems are quite common in these projects.



# Integrated Pre-Design Issues

## Existing Conditions

### What is the existing total energy profile of the home? Are there moisture problems?

If a client wants to dramatically improve the overall energy performance of the home, then the following assessment tools should be considered for evaluating current energy use:

- Energy bill analysis – review all bills—electric, gas, fuel oil, cordwood, etc.—covering at least one full year. The preference is to analyze energy use over several years.
- An energy feedback/logging device, such as The Energy Detective, which is used to measure electricity usage.
- Blower door testing
- Infrared imaging
- Duct blaster testing

Because moisture management is also critical to the long-term performance and durability of a home, evaluate how the existing building envelope wets and dries, and evaluate how energy improvements being considered will affect moisture management. The best way to do this is to observe the building and the immediate site during both a typical and a wind-blown rain event, and augment with moisture meter readings of materials.

## Scope

### How much of the existing structure (and site) will be remodeled as part of the deep energy retrofit?

A deep energy retrofit is likely to involve major modifications to the entire building envelope and the space conditioning system(s). Here are some pre-design principles to consider as you brainstorm just what will and what will not be involved in the whole-house deep energy retrofit.

If heat loss and heat gain are being much more keenly managed, then moisture must be managed as well. Examples include:

- A slightly damp basement without perimeter drainage that has never been a problem may become a problem when insulation and air sealing are added to the basement walls and floor requiring the addition of perimeter drainage.
- A face-sealed wall cladding in a wall with little insulation or air sealing may require back-vented cladding (rainscreen detail) and more comprehensive window flashing details when an aggressive package of wall insulation and air sealing is added.
- A house with neither a dedicated ventilation strategy nor spot exhaust fans in the kitchen and baths may require both when it becomes substantially more airtight.

Start with the site and its first-order role in managing energy and bulk water. Examples include:

- Existing and potential drainage patterns and strategies.
- Building envelope drying potential based on perimeter plantings—proximity to building, types of root structures, current and mature heights of plantings.
- Existing and potential solar access (addressing views as well as building geometry and existing and planned vegetation/landscaping).
- Consider site and structure for both ground-mount and rooftop renewable energy systems: PV, solar hot water, and wind turbine.

Also consider:

- Financial incentives. What tax subsidies, insurance premium reductions, green mortgage programs, and other incentives might be available that would bring major energy retrofits into financial reach?
- The elimination of one or more space conditioning systems. If heating and cooling loads can be reduced enough, it may be possible to downsize or eliminate heating or cooling systems (or both).
- Compliance with LEED for Homes Innovation and Design Process Credit ID 1—“Integrated Project Team”—and ID 2 “Quality Management for Durability.” LEED for Homes Program Pilot Rating System (Version 1.11a)
- Finished products – cabinets, trim, flooring. Can these be “downgraded” for use in a basement, workshop, or auxiliary space?
- On-site construction waste processing – ground wood, gypsum board, block as mulch, soil amendment and driveway/sidewalk base, respectively. Many organic-based or mineral-based site and building materials can be processed for use on site, but it takes planning and sequencing to make sure that the materials are properly processed, stockpiled, and applied.

## Sequencing

### Are there aspects of the design that can lend themselves to sequencing of work to minimize the time homeowners cannot use the space?

Most of the structure and living spaces are likely to be involved in a whole-house deep energy retrofit, so it is important to assess the needs of the homeowner for use of the space during construction. Does the homeowner need to occupy the home during the retrofit?

Consider how the work could be sequenced to maximize the utility of the home to the owners over the course of the project.

Start thinking about the structure from the exterior.

Exterior—as opposed to interior—retrofits to improve building envelope performance have two distinct advantages:

- Potential for better continuity of the air and thermal barriers;
- Significantly less disruption to occupant activities and well-being.

## The Impact of Climate

### What changes to building envelope and HVAC performance work the best for the climate and particular site?

A deep energy retrofit of a two-story home with a basement in Ohio, a split-level coastal home on piers on the coast of Southern California, and a ranch slab-on-grade home in Florida will all involve very different optimal combinations of building envelope and HVAC system changes. The importance of the glazing area and thermal properties of windows varies, the benefit from higher levels of wall and roof insulation is quite different, and the impact of state-of-the-art space heating and space cooling equipment will range widely, all based on site and climate. The best way to analyze the options is to use an energy modeling tool, exploring how various changes in building envelope and HVAC performance optimize the remodeled home’s performance.



# strategies



## Project Scope

### Includes:

- Passive solar design considerations
- Comprehensive building envelope upgrade/redesign (from framing cavity to exterior)
- Vapor profile (determination of drying potential/direction)
- Bulk/capillary water management
- Upgraded/integrated mechanicals
- Space conditioning
- Domestic hot water
- Ventilation—whole-house and spot exhaust
- Lighting
- Renewable energy systems
- Solar water
- Photovoltaic
- Systems analysis/modeling to integrate all of the above

### Does not include:

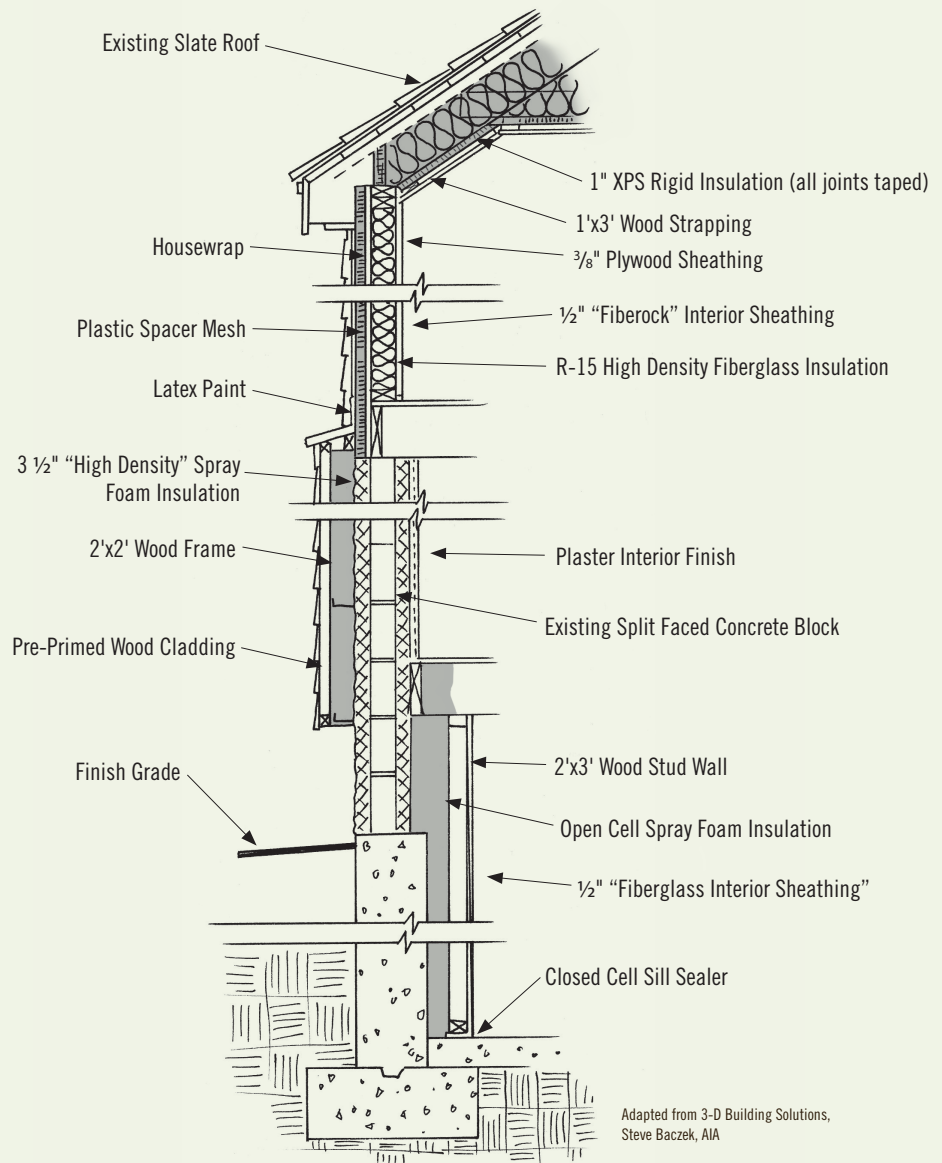
- Interior walls – See Gut Rehab
- “Wet” rooms – kitchen, bath or laundry - See Kitchen and Bathroom
- Interior finishes - See Bedroom, Living & Working
- Landscaping and outdoor water use – See Outdoor Living
- Furniture and fittings - See Bedroom and Living & Working

## Strategies by Building System

### General Design and Construction Strategies

- Ensure durability **IDP1**
- Conduct a home performance audit **IDP2**
- Optimize energy performance during design **IDP3**
- Manage noise **IDP4**
- Design with air quality in mind **IDP5**
- Design for a sustainable lifestyle **IDP6**
- Employ universal design **IDP7**
- Design in sheltered entryway **IDP9**
- Control the spread of pollutants **IEQ158**
- Manage construction and demolition waste **MR107**
- Use computer modeling to determine heating and cooling loads **EA45**
- Configure for solar access **EA100**
- Provide proper moisture management strategies **IDP24**

### Cold Climate Deep Energy Retrofit Detail



Adapted from 3-D Building Solutions, Steve Baczek, AIA



- Test for and appropriately handle hazardous materials **IEQ159**
- Conduct lead-safe work **IEQ160**
- Assess vapor profiles of new assemblies **IDP25**
- Ensure that window and skylight installations include proper air sealing and flashing **IDP27**

### Site

- Minimize site disturbance **SS29**
- Use site-chipped/ground clean wood waste as erosion control **SS39**

### Foundation

- Insulate floor slab and foundation walls **IDP27**
- Install a radon mitigation system **IEQ163**

### Building Envelope

- Provide proper moisture management strategies **IDP24**
- Optimize energy performance **EA48, EA50, EA51, EA52, EA53, EA54**
- Use high-recycled-content, formaldehyde-free insulation **MR117**
- Provide a durable, reflective roof **MR120**
- Replace existing windows **EA59**
- Specify different window glazings for different orientations **EA60**
- Install awnings or other exterior window shading system **EA62**
- Use FSC-certified wood **MR118**
- Install a durable wall cladding **MR119**

### HVAC

- Evaluate different heat distribution options **EA46**
- Consider alternatives to conventional refrigerant-cycle air conditioning **EA65**
- Optimize HVAC systems **EA63, EA64, EA66, EA67, EA69, EA70, EA71**
- Discontinue unconditioned basement or crawl-space ventilation **EA74**
- Avoid ozone-depleting refrigerants **EA75**
- Provide appropriate venting of all combustion-based heating and water heating equipment **IEQ168**

### Plumbing

- Reconfigure plumbing to distribute domestic hot water efficiently **EA77**
- Choose high-efficiency water heaters **EA79**
- Insulate water heater **EA80**
- Insulate hot water pipes **EA81**

### Lighting and Electrical

- Plan for the future with wiring and cabling needs **MR121**
- Provide daylighting **EA83**
- Provide appropriate mix of color correct ambient and task lighting **EA84**
- Install energy-efficient electric lighting **EA85**
- Provide appropriate lighting controls as needed **EA90**

### Equipment

- Select and properly maintain energy-efficient equipment **EA91, EA92, EA93, EA94, EA95, EA99**
- Consider the energy toll of small appliances **EA96**
- Manage phantom loads **EA98**

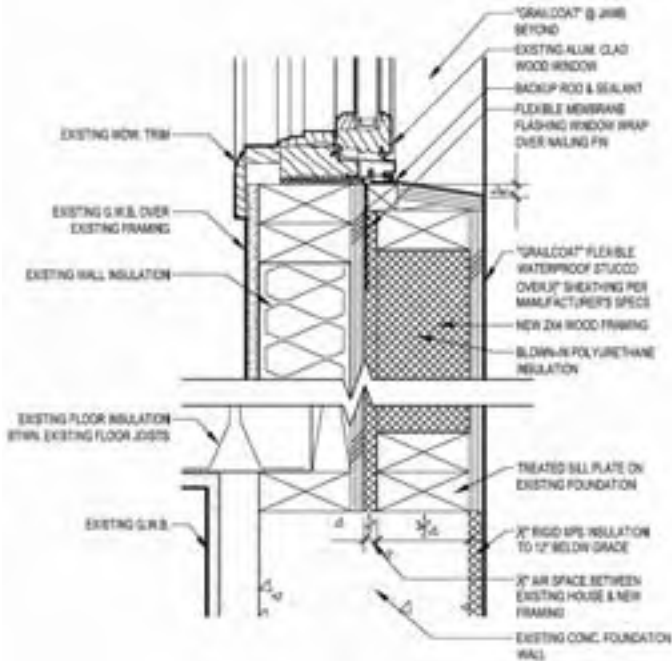
### Energy Sources

- Configure for solar access **EA100**
- Consider solar water heating **EA101**
- Consider a solar electric (photovoltaic) system **EA102**

### Use

- Educate homeowner for green living **EA103, EA104, EA105**

### Wall Section Detail



Wall section from Deep Energy Retrofit case study - see next page. See page 152 for a larger view.

# case study

**Location:** Boulder, Colorado  
**Homeowners:** John and Vicky Graham  
**Architect:** Andy Johnson, DAJ Design  
**General Contractor:** Eric Doub, Ecofutures Building Inc.  
**Area affected:** Remodeled existing 1,000 ft<sup>2</sup>; added 700 ft<sup>2</sup>

*“Most of the choices we made on this project were driven by our desire to be as ‘green’ and as net-zero as possible while creating our ‘dream home.’ We hope that our house might inspire others to consider including some of the amazing green building technologies currently available in their own projects.”* — John Graham



exterior before

## Overview and Scope

In deciding to remodel, the owners of this 1,000 square-foot 1970s ranch in Boulder were seeking to both add space and make dramatic energy improvements. Like other houses in the neighborhood, this one had single-pane windows and no insulation in the walls, making it drafty in the winter and “an oven” in the summer. The family had made some improvements five years earlier, replacing windows, adding insulation, and installing radiant-floor heat, but they didn’t have the experience to take it as far as they would have liked. This time, wanting more comprehensive improvements, the family hired a contractor with experience in high performance building. Eric Doub’s team retrofitted the existing space for energy efficiency, and remodeled it to include a home office in the above-ground space, and a play area in the basement. Adding 700 square feet gave them a new dining area, expanded the kitchen and great room, and improved solar access and lighting. Financial incentives helped the family afford a renewable energy system that will produce more electricity than the home will use. Expected to provide 130% of the home’s energy needs, the system will feed excess energy back into the electrical grid and, once plug-in electric vehicles become available, power the family car.

## Design Approach

Super-insulating and air sealing throughout the home improves comfort and passive survivability, allowing the home to stay warm without heating for a few days in 0°F, cloudy weather. A project manager knowledgeable in building science best practice was always onsite to ensure that proper detailing, critical to a successful energy retrofit, was accomplished. The increased square footage improves the daylighting as well as the livability of the space. An all-electric design allowed the homeowners to cap their natural gas line, which was of particular importance to them because of environmental degradation caused locally by natural gas drilling and distribution. Their efforts to be as green as possible extended from the structure, to energy supply, and to finishes.



## Team and Process

With highly committed homeowners, the team was able to push far beyond typical energy retrofits, and explore new approaches to comprehensive efficiency. At the project outset, the contractor and energy designers worked with the homeowners to calculate electrical loads, and used computer modeling to understand heat and energy flows. This critical step in the design process informed all stages of project development. During construction, homeowners, designers, engineers and the contractor continued to work closely to ensure project success. For example, when the homeowners asked about thermally retrofitting the exterior of the building to minimize disturbance, the contractor verified with modern building science resources that this approach would work well to create continuous air and thermal barriers.

## Finance

With the intention of building their “dream home,” the homeowners selected high-quality finishes throughout, pushed energy measures as far as possible, and took full advantage of Colorado’s new incentives for renewable energy systems. According to the homeowner, construction costs were comparable to other high-end remodels, and with recent announcements that local electricity prices may increase 11% in the next year, the projected return on investment keeps getting better.

## Lessons and Trade-offs

In a comprehensive retrofit of this sort, it can be easy to miss some of the ways in which the systems interact; even manufacturers may overlook details of advanced energy systems. For instance, the team learned that the evacuated tubes for solar hot water could overheat and break if the power went out on a sunny day. To prevent this, they installed a single solar panel that provides backup power so that the pump can continue to circulate water through the tubes. Regardless of their deep-green objectives, the homeowners also had to make some trade-offs. The cost premium for certified wood led the homeowners to forgo using FSC-certified wood exclusively in favor of investing more in renewable energy systems.



Evacuated tube solar water array

*“It feels great to help our clients future-proof their homes. Not only will their investments in energy efficiency and on-site renewables be more valuable year by year, as energy prices increase, but also, as residents they will be more comfortable and healthier because of the ‘build tight, ventilate right’ approach.”*

– Eric Doub



SIP roof assembly



Spray foamed exterior curtain wall



Finished exterior wall



Water-managed, ICF crawlspace foundation

## By System

### Job Site Processes

- 90% of construction waste diverted through on-site reuse, salvage, and recycling

### Site

- Recycled plastic decking
- Xeriscaping and drip irrigation to be installed

## Building Envelope

### Existing

- Walls improved to thermally broken R-28: cellulose blown in to existing frame and walls wrapped with a new external insulated 2'x4' framed wall
- Roof improved to R-70 by 8" spray-in place open cell ½" lb. foam (SPF)
- Below grade improved to R-17: ½" rigid foam and cotton batts in 2'x4' framed wall added to interior
- Prior installation of 1 ½" gypsum concrete floor with radiant tubes over existing slab
- All-in-one vapor barrier, bubble wrap, and ¼" flexible close-cell foam added between gypsum and basement slab

### Addition

- R-27 walls: 2'x6' frame, faced with 1 ½" resilient channel on interior created a 7" wall cavity filled with Icynene spray-foam
- R-42 SIP roof with 3.5" SPF in dropped ceiling for R-50 total
- U-0.15 overall window rating
- FSC-certified and engineered lumber
- 6" core ICF crawlspace with dropped joists to break thermal boundary; 12" SPF between joists

### HVAC

- Operable windows and motorized skylight for ventilation and cooling
- Energy recovery ventilator for continuous ventilation during winter and hot summer days

### Plumbing

- Dual-flush toilet
- Direct-from-solar-tank hot water dispenser to reduce energy demand in cooking

### Lighting

- Natural daylighting enhanced with four solar tubes, two skylights and 30% more glazing
- Compact fluorescent lighting

### Appliances

- Existing Energy Star washer and dryer, plus clothesline
- New refrigerator and electric oven to eliminate use of natural gas
- Separate switch to eliminate phantom loads from electronics.

### Interior Finishes

- Low- and zero-VOC paints and stains
- Waterbased floor finish
- Clay plaster
- Linoleum tile with low-VOC adhesives
- Formaldehyde-free cabinets
- Concrete and sorghum-based countertops
- Oriented strand board sub-floor
- Natural wool carpet

### Energy Sources

- Evacuated tube solar hot water system provides 90%–100% of domestic hot water as well as space heating using in-slab radiant tubes; the system has cloudy cold-snap backup from an on-demand 9-kW modulating electric boiler
- Grid connected solar PV (6.15kW installed on new porch and existing roof)
- EPA-approved wood burning fireplace



# Outdoor Living

A photograph of a garden featuring a stone wall on the left, a wooden structure in the background, and a grill on the right. The garden is filled with various green plants and a stone path.

Outdoor living space can range from a wood-framed deck to a stone patio to a trellised outdoor kitchen. A green outdoor living space expands the “living space” square footage of the home with the least amount of materials, connects the home and its occupants to the outdoors and to nature, and can involve landscaping that improves site drainage and reduces outdoor water consumption. Outdoor living space improvements can be a great do-it-yourself project, but the value of professional design is not to be underestimated. And while we tend to think of this space as private and backyard-focused, frontyard space and wrap-around front porches that can create a sense of neighborhood are important to consider as well.



# Integrated Pre-Design Issues

## Function

### What do the planned uses of the outdoor living space require?

It can be tempting to jump to the nearly ubiquitous pressure-treated deck option before considering just exactly what functions the outdoor living space or structure will serve.

- Does the outdoor space relieve the pressure to add additional interior, and more building-intensive space?
- Can the landscape around the house help homeowners appreciate nature?
- Does the space offer opportunities for additional storage that does not need to be conditioned?
- Is shielding needed from sunlight, wind, light pollution from nearby development, highway noise, unsightly views, or noise from neighbors? Landscape treatments can help to address all of these issues.
- What kind of surfaces are desired outdoors? Is a paved area needed for extra car parking or a basketball hoop? Are there young children for whom soft surfaces are desired? Would homeowners consider alternatives to lawn?
- Can an outdoor kitchen shift cooking out of conditioned space during peak cooling periods, thus saving energy?
- Can semi-outdoors spaces (covered porches, for example) reduce the need for larger entertaining spaces indoors?
- Is the location of the new outdoor living space such that it could or will become additional *indoor* space at some time in the future?

## Existing Conditions

### Are there existing conditions that an addition can improve or conditions that are important to preserve?

- Will the new outdoor living space protect existing natural ecosystems: older trees, vegetation, and natural habitats, and encourage new healthy ones?
- Will the new outdoor features alter or compromise existing light conditions inside the home?
- Will the new outdoor space affect water management on the site or affect the building(s)? With any changes of site features, care should be taken to avoid creating new drainage problems, while solving existing drainage problems.
- Is there an existing structure—a carport or breezeway—that might be creatively incorporated into new outdoor living space?

# strategies



## Project Scope

### Includes:

- Patios
- Decks – attached and unattached
- Trellis
- Lawn area
- Landscaping
- Porous pavement
- Rainwater catchment

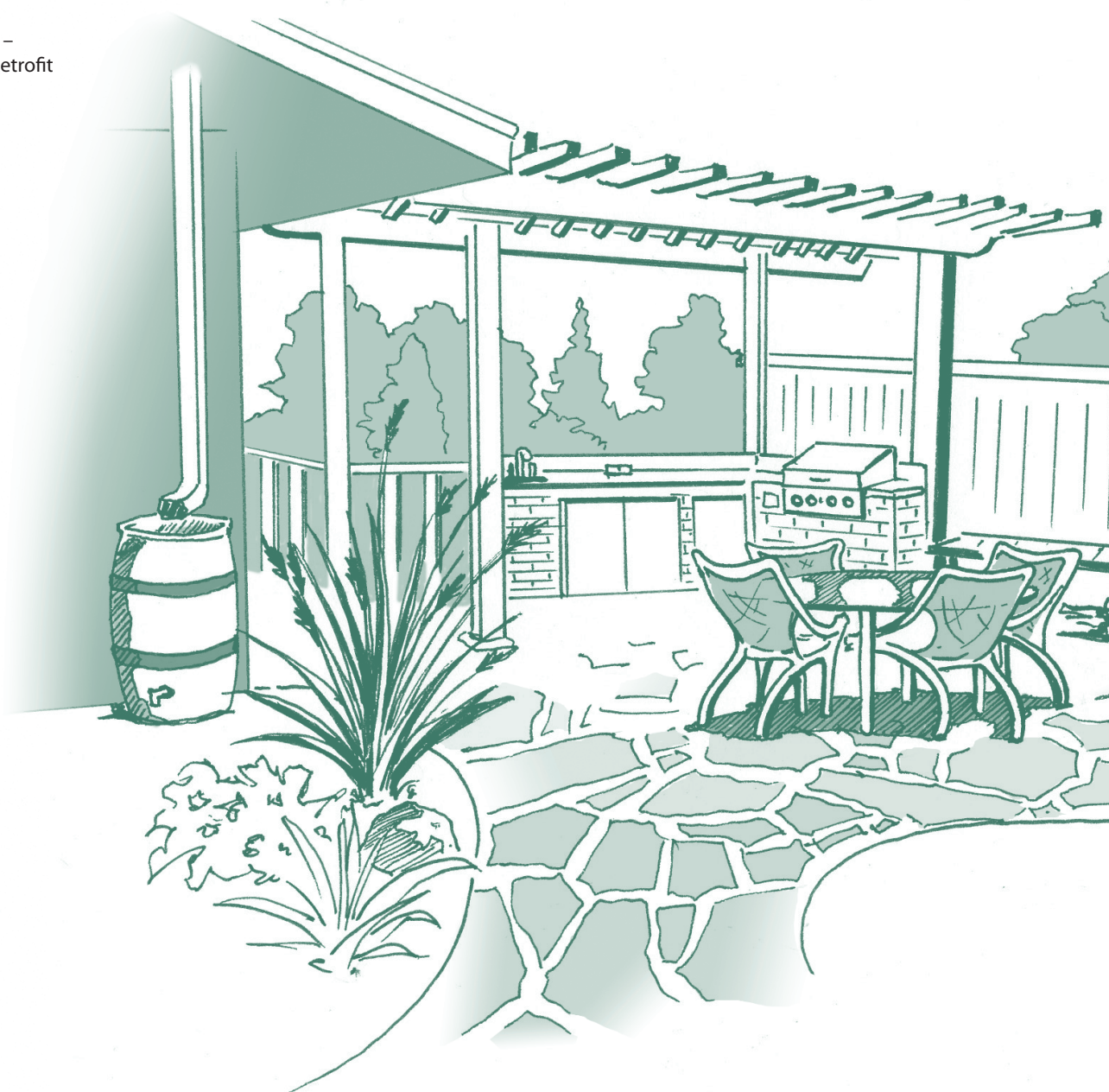
### Does not include:

- Storage sheds
- Garages
- Playhouse
- Renewable energy –  
See Deep Energy Retrofit

## Strategies by Building System

### General Design and Construction Strategies

- Ensure durability IDP1
- Manage noise IDP4
- Design with air quality in mind IDP5
- Design for a sustainable lifestyle IDP6
- Maintain adequate slope and drainage away from house when creating outdoor living areas IDP14
- Design landscape features to minimize heat island effects IDP17
- Design landscape to encourage outdoor activities IDP16
- Design to minimize outdoor water use IDP18
- Design to support connection with nature IDP15
- Install track-off mats at exterior doors IEQ161



- Manage construction and demolition waste **MR107**
- Control the spread of pollutants **IEQ158**
- Clean-up and dispose pressure treated sawdust and shavings appropriately **IEQ162**

### Site

- Make use of trees and landscaping to reduce cooling loads **SS30**
- Minimize site disturbance **SS29**
- Modify landscaping to provide solar access **SS31**
- Minimize contiguous impervious surfaces and facilitate infiltration **SS32**
- Provide porous pavement **SS33**
- Reduce lawn area **SS34**
- Provide wildlife habitat **SS35**
- Use landscape features to shield the house **SS36**
- Provide rainwater collection system **WE40**
- Provide for edible plants in the landscape design **SS37**
- Landscape to minimize chemical use **SS38**

### Outdoor Structures

- Consider reuse of existing materials **MR108**
- Consider a patio rather than a wooden deck **MR109**
- Use environmentally preferable patio materials **MR113**
- Properly detail connection between deck and house **IDP28**
- Use naturally rot-resistant, responsibly produced wood for decks **MR110**
- Use FSC-certified wood **MR118**
- Use recycled content plastic or composite decking boards **MR112**
- Choose less harmful pressure treated lumber **MR111**
- Clean-up and dispose of pressure-treated saw dust and shavings appropriately **IEQ162**

### Lighting and Electrical

- Install energy-efficient electric lighting **EA85**
- Select outdoor lighting to minimize light pollution **EA88**
- Provide appropriate outdoor lighting controls as needed **EA89**
- Manage phantom loads **EA98**

### Equipment

- Choose an efficient hot tub or spa **EA97**

### Furniture and Fittings

- Choose environmentally friendly outdoor furniture and accessories **MR154**

### Use

- Use environmentally preferable cleaning materials and strategies **IEQ196**
- Store all toxic chemicals far away from living space **IEQ197**
- Educate homeowner for green living **EA103, EA104, EA105, EA106**





# case study

**Location:** Austin, Texas

**Homeowners and designers:** Grace Riggan and Joshua Bowles

**Area affected:** ¼-acre lot

*“To develop a garden is an important part of how you live—no matter where you live. It isn’t just that you’re sitting out there instead of using the AC. The garden can be a real cultural exchange—it opens you up to the community.”* – Grace Riggan



garden before

## Overview and Scope

Over the last ten years, Grace Riggan and Joshua Bowles have transformed their yard from a crabgrass and cement lot into an urban oasis. The house’s meditation room opens out onto a deck that overlooks the garden. Hidden from the road by a large wall made of salvaged stone, the garden provides a haven for both wildlife and humans. Native plants attract birds and butterflies, mature pecan trees provide food for everyone, and numerous cacti and agave species are found along the meandering paths. Located in an older neighborhood one mile from downtown, the garden recently won the City of Austin’s “Green Garden Award.”

## Design Approach

As children, both Grace and Joshua loved spending time on their grandparents’ small farms, and they wanted the pattern of their home to reflect the way in which household activities flowed smoothly from the farmhouse to porch to farm. The open-air deck and lightly conditioned meditation room provide both a thermal and psychological transition that, according to Grace, allows them to set the house thermostat on a more conservative setting. The curved and gated stone wall, patterned from Mexico’s walled gardens, provides total privacy and encloses the entire yard while remaining inviting on a human scale. A wide variety of details, from the protected fence-top water trough for visiting birds, to the hand-planed and unfinished cedar plank deck floor, make the garden both an environmental and aesthetic accomplishment.

## Team and Process

Other than a stand of large pecan trees in the back, the original site was aesthetically unappealing. Eager to make the space their own, the couple started at the edges of the property, replacing weeds and pavement with native drought-tolerant



plants. The design of the garden emerged bit by bit as they worked; the many limestone boulders they salvaged from job sites were piled near the sidewalk for months before they started to build a wall. Over the years, the couple’s many outdoor projects helped them befriend the neighbors.

*“When we started we didn’t really think of ourselves as gardeners, but we couldn’t wait to interact with the site. I started trying to break up the dirt and plant native plants. The process of letting it unfold, learning as you go—that’s how you become a part of the garden, building it around you in a natural order.”* – Grace Riggan



Unfinished, hand-planed cedar deck



Landscape screen

*“There isn’t any outdoor lighting. We’ve been trying to get rid of the light. It drove us crazy that we never could have real darkness in the city.”* – Grace Riggan



Meditation room with reclaimed cypress Shoji screens



Lush native hand-watered plants

## Finance

Although the garden may look extravagant, it was not an expensive renovation. Instead, changes were made gradually, with everything in the garden done out of pocket. Grace attributes the organic look and feel of the space to this slower timeframe.

## Lessons and Trade-offs

Addressing water conservation was one of the trickiest aspects of the project. In the dry Austin climate, even native cacti used for xeriscaping need some watering to look their best. The couple did not find an irrigation system that they were confident would not eventually waste water through leakage. Currently, Grace waters by hand with a hose, using rainwater from a 1,500-gallon rainwater collection system. Although its eight-foot diameter tank manages to achieve capacity from just two to three inches of rain, it occupies a lot of space. The couple is still looking for better ways to manage trade-offs between water-efficiency, use of space, and convenience.

## By System

### Site

- Paving reduced significantly
- Paving stones on paths
- Minimal lawn area
- Existing pecan trees maintained for shade and food for humans and wildlife
- Plants and a safe watering hole provided for wildlife
- 1500-gallon rainwater collection system
- Rocks used for private seating nooks throughout the garden

### Structure

- Cedar deck, hand-planed, without finish
- Stone wall made of salvaged boulders shields the garden from the road
- Cedar and steel fence
- Shoji screen of reclaimed cypress separates meditation room and deck
- Gates and landscape screen of regional, planed-finish, white oak, with no sealant

### Lighting

- No lighting outdoors

# Strategy Library



## Innovative Design Process (IDP)

### General Design and Construction Strategies

1. Ensure durability
2. Conduct a home performance audit
3. Optimize energy performance during design
4. Manage noise
5. Design with air quality in mind
6. Design for a sustainable lifestyle
7. Employ universal design
8. Optimize interior layout
9. Design in a sheltered entryway
10. Design for storage
11. Provide a pantry
12. Design a practical and usable kitchen recycling center

### Site

13. Maintain adequate slope and drainage away from building
14. Maintain adequate slope and drainage away from house when creating outdoor living areas
15. Design to support connection with nature
16. Design landscapes to encourage outdoor activities
17. Design landscape features to minimize heat island effects
18. Design to minimize outdoor water use

### Foundation

19. Provide proper moisture control at footings, slab perimeter, and foundation walls
20. Upgrade basement floor
21. Upgrade exterior basement walls
22. Include capillary break between all concrete and sill plates
23. Provide appropriate insect control

### Building Envelope

24. Provide proper moisture management strategies
25. Assess vapor profile of new assemblies
26. Properly detail window sills in wet areas
27. Ensure that window and skylight installations include proper air sealing and flashing
28. Properly detail connection between deck and house

## Sustainable Sites (SS)

### Site

29. Minimize site disturbance
30. Make use of trees and landscaping to reduce cooling loads
31. Modify landscaping to provide solar access
32. Minimize contiguous impervious surfaces and facilitate infiltration



- 33. Provide porous pavement
- 34. Reduce lawn area
- 35. Provide wildlife habitat
- 36. Use landscape features to shield the house
- 37. Provide for edible plants in the landscape design
- 38. Landscape to minimize chemical use
- 39. Use site-chipped/ground clean wood waste as erosion control

## Water Efficiency (WE)

### Site

- 40. Provide rainwater collection system

### Plumbing

- 41. Install low-water-use kitchen faucet
- 42. Replace toilets with high-efficiency toilets
- 43. Install low-water-use showerheads
- 44. Install water-conserving bathroom faucet aerator

## Energy and Atmosphere (EA)

### General Design and Construction Strategies

- 45. Use computer modeling to determine heating and cooling loads
- 46. Evaluate different heat distribution options

### Foundation

- 47. Insulate floor slab and foundation walls

### Building Envelope

- 48. Optimize energy performance
- 49. Install attic insulation
- 50. Consider a radiant barrier in the attic
- 51. Conduct blower door test (before and after)
- 52. Conduct room-to-room pressurization testing
- 53. Conduct infrared imaging (before and after)
- 54. Complete thermal bypass inspection/resolution
- 55. Airseal/insulate rim joists
- 56. Upgrade existing windows
- 57. Upgrade existing exterior door
- 58. Weatherstrip doors and windows
- 59. Replace existing windows
- 60. Specify different window glazings for different orientations
- 61. Provide shading of skylights as needed
- 62. Install awnings or other exterior window shading system

### HVAC

- 63. Use ACCA Manual J, S, and D in mechanical system design
- 64. Provide appropriate controls and zoning for HVAC
- 65. Consider alternatives to conventional refrigerant-cycle air conditioning

- 66. Select high-efficiency HVAC equipment
- 67. Install programmable thermostats
- 68. Conduct duct tightness test (before and after) in homes with forced air systems
- 69. Properly commission new (or tune existing) HVAC systems
- 70. Properly seal and insulate HVAC distribution system
- 71. Make sure ducting is clean
- 72. Provide air-lock dryer vent
- 73. Minimize dryer duct length and number of turns
- 74. Discontinue unconditioned basement or crawl-space ventilation
- 75. Avoid ozone-depleting refrigerants
- 76. Install ceiling fan

### Plumbing

- 77. Reconfigure plumbing to distribute domestic hot water efficiently
- 78. Install on-demand hot water recirculation system
- 79. Choose a high-efficiency water heater
- 80. Insulate water heater
- 81. Insulate hot water pipes
- 82. Set water temperature no higher than necessary

### Lighting

- 83. Provide daylighting
- 84. Provide appropriate mix of color correct ambient and task lighting
- 85. Install energy-efficient electric lighting
- 86. Avoid recessed lights in insulated ceilings or use Insulation-Contact fixtures
- 87. Provide adaptable lighting for multiuse spaces
- 88. Select outdoor lighting to minimize light pollution
- 89. Provide appropriate outdoor lighting controls as needed
- 90. Provide appropriate indoor lighting controls as needed

### Equipment

- 91. Properly maintain equipment
- 92. Select a high-efficiency, H-axis clothes washer
- 93. Install an energy-efficient refrigerator
- 94. Choose an energy-efficient dishwasher
- 95. Install energy-efficient cooking appliances
- 96. Consider the energy toll of small appliances
- 97. Choose an efficient hot tub or spa
- 98. Manage phantom loads
- 99. Select energy-efficient Energy Star-rated office equipment

### Energy Sources

- 100. Configure for solar access
- 101. Consider solar water heating
- 102. Consider a solar electric (photovoltaic) system

## Use

103. Provide a homeowner's manual of green features and O&M practices
104. Complete client education
105. Practice an energy-efficient, healthy lifestyle
106. Provide for line drying options for laundry

## Materials and Resources (MR)

### General Design and Construction Strategies

107. Manage construction and demolition waste

### Site

108. Consider reuse of existing materials
109. Consider a patio rather than a wooden deck
110. Use naturally rot-resistant, responsibly produced wood for decks
111. Choose less harmful pressure treated lumber
112. Use recycled content plastic or composite decking boards
113. Use environmentally preferable patio materials

### Foundation

114. Use fly ash in concrete
115. Use biobased form-release agent or permanent forms

### Building Envelope

116. Minimize wood use with Advanced Framing or SIP construction
117. Use high-recycled-content, formaldehyde-free insulation
118. Use FSC-certified wood
119. Install a durable wall cladding
120. Provide a durable, reflective roof

### Lighting and Electrical

121. Plan for the future with wiring and cabling needs

### Plumbing

122. Consider the environmental preferability of piping material
123. Include a plumbing access panel
124. Install readily accessible, single-throw shut-off valve
125. Install drain and drain pan for clothes washer located over finished space

### Walls and Ceilings

126. Install environmentally preferable interior sheathing
127. Select environmentally preferable interior doors
128. Frame for installation of future grab bars
129. Consider alternative wallcovering products
130. Use appropriate sheens for paints and finishes

131. Consider natural finishes
132. Consider tile and tile trim pieces with recycled content

### Floors and Flooring Products

133. Consider reuse of existing flooring and subflooring
134. Select wood subflooring that is FSC-certified and low-formaldehyde
135. Consider flooring made from certified or reclaimed wood
136. Consider flooring made from natural or rapidly renewable materials
137. Refinish wood floors using environmentally preferable processes and products
138. Choose environmentally preferable carpet and rug products
139. Select carpet cushion that does not contain brominated flame retardants

### Furniture and Fittings

140. Consider reusing clean existing cabinetry or buying salvaged
141. Consider reusing clean existing furnishings and fixtures or buying salvaged
142. Consider cleaning existing furniture or purchasing salvaged/antique furniture
143. Purchase the best, most durable furniture possible within a given budget
144. Select ergonomic furniture and office equipment
145. Evaluate use of cabinetry and furniture made from particleboard or MDF
146. Select compact furniture that incorporates storage
147. Select solid furniture that is made from green and safe sources
148. Select cabinets made from greener materials
149. Install environmentally preferable countertops
150. Select furniture from suppliers that are practicing fair and safe manufacturing processes
151. Select upholstered furniture with care
152. Choose environmentally preferable fabrics
153. Support local artisans as well as indigenous peoples
154. Choose environmentally friendly outdoor furniture and accessories

### Use

155. Provide for paper recycling
156. Select materials that are easy to clean
157. Consider using bulk-product dispensers for body care products

# Indoor Environmental Quality (IEQ)

## General Design and Construction Strategies

- 158. Control the spread of pollutants
- 159. Test for, and appropriately handle, hazardous materials
- 160. Conduct lead-safe work
- 161. Install track-off mats at exterior doors
- 162. Clean-up and dispose pressure treated sawdust and shavings appropriately

## Foundation

- 163. Install a radon mitigation system
- 164. Install CO and smoke alarms

## Building Envelope

- 165. Isolate attached garages

## HVAC

- 166. Install effective kitchen ventilation
- 167. Install effective bath ventilation
- 168. Provide appropriate venting of all combustion-based heating and water heating equipment
- 169. Consider stand-alone equipment to address moisture
- 170. Provide for forced-air system pressure relief
- 171. Provide fresh air as part of ventilation system
- 172. Provide for additional ventilation and air conditioning needs in certain activity areas
- 173. Provide for additional air filtration
- 174. Install appropriate HVAC in the finished basement

## Plumbing

- 175. Install undersink water filtration system
- 176. Install water filter on showerhead

## Lighting and Electrical

- 177. Use prudent avoidance with electromagnetic fields
- 178. Provide controllable interior shading

## Floor and Flooring Finishes

- 179. Avoid carpeting in high moisture areas
- 180. Choose hard-surface flooring
- 181. Install appropriate finish flooring in basements
- 182. Use area rugs instead of wall-to-wall carpeting

## Wall and Ceiling Finishes

- 183. Use non-paper-faced gypsum board in moist areas
- 184. Limit use of wallcoverings in high moisture areas
- 185. Use low- or zero-VOC interior paints and finishes
- 186. Limit use of VOC emitting wallcoverings
- 187. Use low- or zero-VOC construction adhesives, caulking, and sealants

## Furniture and Fittings

- 188. Choose furniture and fittings that will not absorb moisture
- 189. Choose furniture finished with least-toxic products

- 190. Avoid fully upholstered furniture where moisture may be a problem
- 191. Minimize use of plush and porous materials
- 192. Select furniture that is easy to clean
- 193. Select window treatments with health considerations in mind
- 194. Select mattress and bedding with attention to health issues
- 195. Choose interior accessories with care

## Use

- 196. Use environmentally preferable cleaning materials and strategies
- 197. Store all toxic chemicals far away from living space
- 198. Be attentive to chemicals that might be stored in close proximity to a finished basement room



# Innovative Design Process (IDP)

## General Design and Construction Strategies

### 1. Ensure durability

#### Strategy included in: All Projects

Durability applies to design, materials and construction. It means combining these in such a way that the project responds to forces that challenge its durability—water, wind, ultraviolet radiation, pests, use and abuse, natural disasters. It is also about designing a project with lasting aesthetics and utility.

Ensuring durability involves quality assurance (of design and material selection) and quality management (construction). To ensure durability, carry out a Durability Evaluation, such as that called for in the LEED for Homes program or the building assessment form listed as an appendix to this Guide.

#### Potential Issues:

Designing for durability is about integrating energy efficiency with indoor air quality, energy efficiency with moisture management, and materials selection with all three. In remodeling, it is also about integrating all of these for the new work with the existing home.

#### Related Strategies:

IDP5, IDP9, IDP13, IDP19, IDP24, IDP25, MR119, MR120, MR124, IEQ166, IEQ167

#### References/Resources:

“Read This Before You Design, Build, Or Renovate” [www.buildingscienceconsulting.com/resources/mold/](http://www.buildingscienceconsulting.com/resources/mold/) (particularly the introductory section, “The Building Connection”)

LEED for Homes Innovation and Design Process Credit 2 [www.usgbc.org/ShowFile.aspx?DocumentID=2267](http://www.usgbc.org/ShowFile.aspx?DocumentID=2267)

### 2. Conduct a home performance audit

#### Strategy included in: Basement, Home Performance, Major Addition, Gut Rehab, Deep Energy Retrofit

Both private contractor home performance specialists and “whole house” weatherization programs conduct comprehensive home energy analyses that include all areas of performance—moisture flows, thermal comfort, indoor air quality, combustion safety, and durability. This type of assessment represents systems thinking and systems integration and ensures that energy improvements do not result in negative unintended consequences. This type of assessment also ensures that energy improvements take into account ALL loads—space heating, space cooling, ventilation, water heating, appliances, and plug loads—and climate and site factors so that the package of energy improvements is customized as well as optimized.

#### Potential Issues:

Each building must be evaluated for the cost and benefit of managing different energy loads and the loads evaluated for their impact on overall building performance (health and safety, durability). And although the number of building professionals trained and capable of this type of home assessment is growing, there really is no one certification that covers systems-integrated, building science-based residential building assessment; the demand is quickly outstripping the supply of qualified professionals.

#### Images: Home Performance Testing During an Audit (3 images)



#### Related Strategies:

IDP25, EA45, EA48, EA53, EA54, EA63, EA74, IEQ171

#### References/Resources:

Saturn On-line Training for the Building Technician [www.srmi.biz/Online\\_Training.htm](http://www.srmi.biz/Online_Training.htm)

BPI Building Professional Certification [www.bpi.org/contractor/cert.htm](http://www.bpi.org/contractor/cert.htm)

“Combustion Safety Test for Vented Appliances” [www.bpi.org/documents/Gold\\_Sheet.pdf](http://www.bpi.org/documents/Gold_Sheet.pdf)

“Weatherization Plus – Next Generation” [www.waptac.org/sp.asp?mc=what\\_overview\\_history](http://www.waptac.org/sp.asp?mc=what_overview_history)

“Iowa Weatherization Program – Weatherization Standards” [www.regreenprogram.org](http://www.regreenprogram.org)

*Insulate and Weatherize*, Bruce Harley, Taunton Press

### 3. Optimize energy performance during design

#### Strategy included in: Major Addition, Gut Rehab, Deep Energy Retrofit

Computer modeling for energy efficiency is the best way to determine how design elements impact the energy efficiency of the project. The computer model determines how all elements of the home interact, from the foundation, walls and attic to the mechanical equipment. Energy models allow the user to determine the overall efficiency of the home, can predict energy bills, and some models even show how energy-efficient a home is compared to code.

Energy modeling allows users to determine the effectiveness of all envelope and mechanical equipment on the home’s overall energy use. Many professionals use energy modeling to prioritize energy related decisions, especially when they are dealing with a tight budget.

For example, is it better to spend \$1,000 on increased insulation in the attic, or a more efficient heat pump?

Integrated energy design is also a process that involves the mechanical system designer working in concert with the designer or remodeling contractor. By working together, opportunities are often found to optimize heat distribution (baseboard hydronic radiators or forced-warm-air registers, for example) when extra investment is made in high-performance windows and superinsulated wall sections. This integrated energy design also creates an opportunity to ensure that space is provided in the design for ducting, plumbing chases, and equipment.

The most popular modeling programs are REM/Rate, TREAT, and ENERGY-10. The IRS Energy-efficient New Homes Tax Credit also includes a list of certified energy modeling programs.

Whole-house green remodeling projects should set a HERS rating target value (such as that just established by the City of Boulder, CO for residential remodeling of a 25 HERS rating) and design to meet the target.

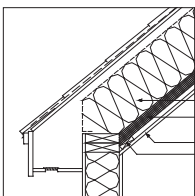
#### Potential Issues:

Optimizing energy performance is very site- and climate-specific; if you don't model all of the existing and potential loads in the home, it is very difficult to optimize the home's new performance. Integrated energy design practices often are win-win strategies that improve overall performance and/or improve cost-benefit ratios. Keep in mind that managing energy intensively requires that moisture and its movement be evaluated and managed with equal intensity.

ASHRAE is working on climate-specific deep energy retrofit protocols for homes. Their schedule for this work is uncertain, but USGBC and ASID will incorporate their work into REGREEN when it becomes publicly available. For more information on carbon neutral existing home retrofit, see the ACI web reference listed below.

Occupant behavior has a huge impact on actual energy usage in any home. Clear communication and a homeowner's manual can go a long way toward ensuring that the house will be managed for the optimal energy performance designed and built into the project.

#### Details: Roof Retrofit Insulation and Interior Roof Retrofit



#### Related Strategies:

IDP1, IDP2, IDP25, IDP31, EA45, EA48, EA63, EA100, EA101, EA102

#### References/Resources:

REMrate - [www.archenergy.com/products/rem/](http://www.archenergy.com/products/rem/)

TREAT - [www.treatsoftware.com/treat\\_intro.html](http://www.treatsoftware.com/treat_intro.html)

Energy-10 - [www.sbicouncil.org/store/e10.php](http://www.sbicouncil.org/store/e10.php)

IRS Allowed Energy Models - [www.natresnet.org/programs/taxcredit\\_software/directory.aspx](http://www.natresnet.org/programs/taxcredit_software/directory.aspx)

“ACI Summit: Moving Existing Homes Toward Carbon Neutrality”

[www.affordablecomfort.org/event/aci\\_summit\\_moving\\_existing\\_homes\\_toward\\_carbon\\_neutrality](http://www.affordablecomfort.org/event/aci_summit_moving_existing_homes_toward_carbon_neutrality)

## 4. Manage noise

### Strategy included in: All Projects

There is growing evidence that noise can be an indoor environmental quality problem. Along with the direct impacts of noise, such as impaired hearing, problems such as elevated blood pressure and heart rate, cardiovascular constriction, sleep loss, depressed learning rates, and the production of stress hormones are now being attributed to noise. Sources of noise can be external (trucks passing by outside the home) or internal (children, furnace, etc.).

**Construction:** Strategies include installation of layers of sound-control materials in floors, ceilings, or walls; building offset wall studs or resilient channel (hat-track) furring on framing members; installation of cellulose or mineral wool cavity-fill insulation even in interior walls; installation of sound-control wall panels, installation of cork or other sound-control underlayment in floor systems; installation of carpeting or cork flooring; mounting mechanical equipment and ducting using vibration-control brackets; minimizing duct elbows and constrictions; and selection of equipment with low sound ratings (often listed in sones for exhaust fans and dBA for appliances).

**Appliances:** Kitchen appliances can be a significant source of unwanted noise in homes. When selecting refrigerators, dishwashers, and other appliances, look for noise ratings, which are usually listed in the logarithmic decibel-A scale (dBA). Appliances vary considerably in noise ratings and, unfortunately, many manufacturers do not provide that information in their product literature. The quietest dishwashers have noise ratings below 45 dBA, which is almost unnoticeable in a kitchen if there is conversation.

Getting quantitative information on sound levels of appliances is very difficult. While a few manufacturers provide dBA sound ratings for their appliances, most do not. It is common to see reference to a “sound control package” or a qualitative description of sound levels, but consistent metrics are needed to gauge noise from appliances. The best source for this information may be *Consumer Reports*.

**Finishes:** Hard, monolithic surfaces (such as high-density wood composite paneling, gypsum board, ceramic tile) are problematic in managing interior noise; softer, variegated surfaces (such as carpet, cork, grossly woven materials) help to manage it.

### **Potential Issues:**

Some sound-control measures can add significant cost to a remodeling project. Sound-control measures can also add thickness to a wall system—taking away usable floor area. In many cases, there is good synergy between managing air leakage and managing noise generated outside the home.

### **Related Strategies:**

IDP3, EA54, EA56, EA92, EA93, EA94, MR138, IEQ165

### **Resources/References:**

“Building Green...Quietly: Noise Pollution and What to Do About it”  
[www.buildinggreen.com/auth/article.cfm?fileName=100101a.xml](http://www.buildinggreen.com/auth/article.cfm?fileName=100101a.xml)

Noise Pollution Clearinghouse, 888/200-8332 -  
[www.nonoise.org](http://www.nonoise.org)

Rutgers Noise Control Technical Assistance Center -  
[www.envsci.rutgers.edu/org/rntac/tech.shtml](http://www.envsci.rutgers.edu/org/rntac/tech.shtml)

National Council of Acoustical Consultants, 973/564-5859 -  
[www.ncac.com](http://www.ncac.com)

## **5. Design with air quality in mind**

### **Strategy included in: All Projects**

There are a host of considerations related to indoor air quality that should be taken into account during the design phase of just about all remodeling and interior design projects: ventilation, material selection, filtration, etc. EPA’s Indoor Air Quality division has developed a model (I-BEAM) that can be used for both new construction and renovation to address IAQ during both the design and construction phases.

### **Potential Issues:**

The EPA resource covers both new construction and renovation so the user must keep this in mind if applied to just renovation.

### **Related Strategies:**

EA71, EA74, MR137, MR145, MR147, MR152, IEQ163, IEQ165, IEQ166, IEQ167, IEQ171

### **Resources/References:**

“EPA IAQ Building Education and Assessment Model”  
[www.epa.gov/iedweb00/largebldgs/i-beam/text/renovation\\_new\\_construction.html#CR3.3.2](http://www.epa.gov/iedweb00/largebldgs/i-beam/text/renovation_new_construction.html#CR3.3.2)

## **6. Design for a sustainable lifestyle**

### **Strategy included in: Kitchen, Living & Working, Outdoor Living**

As part of a remodeling project, incorporate features that will facilitate environmentally responsible living. Specific measures can include incorporating recycling receptacles, providing convenient storage for bicycles, providing storage for locally produced food, providing composting receptacles in the kitchen and a sturdy composting

bin outdoors; and storage spaces that will encourage organization while discouraging keeping too many belongings that are never used.

### **Potential Issues:**

It is very likely that green remodeling clients will be fully attuned and open to guidance from their designer or remodeler on a sustainable lifestyle that augments the project’s sustainable focus. But the homeowners may need to be directed to information resources, such as those listed below.

### **Related Strategies:**

IDP7, IDP10, IDP11, IDP12, EA105, IEQ196, IEQ197, IEQ198

### **References/Resources:**

[www.greenhomeguide.org/](http://www.greenhomeguide.org/)

## **7. Employ universal design**

### **Strategy included in: Bathroom, Kitchen, Major Addition, Gut Rehab**

The relationship between universal and sustainable design is a strong one. Remodeling homes that maintain their functionality as the owners age or as owners change is resource efficient.

### **Potential Issues:**

Care should be taken on exterior walls to maintain thermal performance as blocking is added that replaces insulation; yet another good argument for considering the addition of exterior rigid insulation as a part of any bathroom remodel. Requirements for finished first floor levels to be the same or nearly the same as finished grade mean that sheltered entryways become that much more important.

### **Related Strategies:**

IDP3, MR109, MR128

### **Resources/References:**

“Residential Remodeling and Universal Design”  
[www.huduser.org/publications/destech/resid.html](http://www.huduser.org/publications/destech/resid.html)

“Universal Design”  
[www.extension.iastate.edu/housing/elderly/udha-ud.html](http://www.extension.iastate.edu/housing/elderly/udha-ud.html)

## **8. Optimize interior layout**

### **Strategy included in: Major Addition, Gut Rehab**

Whenever a remodeling project involves potential reconfiguration of interior spaces, consider how the layout could be modified to better utilize space (including storage), benefit from passive solar heating, more effectively circulate conditioned air (in some cases obviating the need for distributed heat), and reduce the length of hot-water piping runs. Part of the long-term trend of ever-larger houses is driven by the fact that Americans have more stuff than ever before, and storage

space is needed for those belongings; that storage can be more efficient, allowing comfortable living with fewer square feet of living space. Reconfiguration of house layout can significantly improve the potential for passive solar energy to heat a home or for small space-heating or air conditioning systems to effectively heat and cool the space without a full distribution system.

#### **Potential Issues:**

Air circulation in a building is complex, especially when passive solar heat gain and thermal mass are factored in; a designer knowledgeable in passive solar design should be consulted in designing the layout of a home that will rely on natural air circulation to maintain comfort.

#### **Related Strategies:**

IDP10, EA46, EA77, EA84

#### **References/Resources:**

*The Not-So Big House*, Sarah Susanka, Taunton Press, 1998  
[www.notsobighouse.com/](http://www.notsobighouse.com/)

## **9. Design in a sheltered entryway**

### **Strategy included in: Major Addition, Deep Energy Retrofit, Gut Rehab**

Providing a sheltered entry to a home can reduce heat loss and gain, provide protection from UV and water exposure, and provide a place to leave wet shoes and outerwear. There should also be adequate space for hanging coats and storing outdoor shoes. In cold climates, the entry should be an airlock “mudroom” large enough so that homeowners will close one door before opening the next—whether coming in or going out.

#### **Potential Issues:**

Providing a sheltered entry requires a significant amount of space, which can be challenging in a compact home; the space can also be costly to build.

#### **Related Strategies:**

IDP1, IDP3, IEQ161

#### **References/Resources:**

“Remodeling With The Sun”  
[www.homeenergy.org/archive/hem.dis.anl.gov/eehem/97/970508.html](http://www.homeenergy.org/archive/hem.dis.anl.gov/eehem/97/970508.html)

## **10. Design for storage**

### **Strategy included in: Kitchen, Bathroom, Major Addition, Gut Rehab**

Maximizing all opportunities for storage supports less added square footage. In small bathrooms in particular, design in additional storage by framing in interior wall cavities for medicine cabinets and small shelves. There are lots of incidental bathroom items that are appropriate for the 3 ½- to 4-inch deep storage space that interior framing cavities provide. Choice of a sink with cabinet over a pedestal will also give more storage.

#### **Potential Issues:**

It can be hard to make a really tight bathroom appear spacious by filling in open volume with cabinetry. Another approach is to assess adjacent rooms or the hallway into which the tight bathroom opens for additional storage potential.

#### **Related Strategies:**

IDP8

#### **References/Resources:**

*The Not-So Big House*, Sarah Susanka, Taunton Press, 1998  
[www.notsobighouse.com/](http://www.notsobighouse.com/)

## **11. Provide a pantry**

### **Strategy included in: Kitchen**

A pantry that is accessible from the kitchen can provide space-efficient and cost-effective storage space for food and kitchen utensils. Kitchen pantries can be very small—as little as 3' by 3' in floor area—or a full walk-in room. Effective implementation of a pantry can reduce the number of cabinets needed, and because doors are not needed on each shelf within a pantry, overall material use and construction cost can be reduced.

#### **Potential Issues:**

Pantries cannot be provided in every kitchen layout, and where they can be provided, their effective integration often requires significant design experience.

#### **Related Strategies:**

IDP8

#### **References/Resources:**

*The Not So Big House*, Sarah Susanka, Taunton Press, 1998  
[www.notsobighouse.com/](http://www.notsobighouse.com/)

## **12. Design a practical and usable kitchen recycling center**

### **Strategy included in: Kitchen**

Ideally, a kitchen recycling center includes stations or bins for paper, plastic, metal, and compost. It also should largely replace any need for an in-sink garbage disposal. The space for a kitchen recycling center can be incorporated into the new kitchen cabinet layout, or pantry, mudroom, or other adjacent space. Instead of a trash compactor, locating a dedicated recycling center with easy access in your kitchen or utility room will help homeowners practice environmentally responsible lifestyles. Make sure that a recycling set up correlates with your municipality's recycling program. Another option is to design a physical in-house composting system. Worm bins and other techniques are available that can make composting possible in nearly any setting. Outdoor compost containers, into which compost collected in most kitchen composting systems is dumped, must be well-designed to provide airflow and keep animals out.



**Potential Issues:**

Space for a comprehensive recycling center can be challenging, especially to make the space easily accessible so that all household members use it. Make homeowners aware that composting involves more work than in-sink garbage disposals. Someone must be committed to monitoring and maintaining the composting system, or it will fail noticeably. In areas with raccoons, rats, or other problem animals, outdoor compost bins need to be carefully designed to exclude those animals.

**Related Strategies:**

IDP8

**References/Resources:**

*Good Green Kitchen*, Jennifer Roberts

“Kitchen Recycling Center”

[www.toolbase.org](http://www.toolbase.org)

“Composting Guide – Composting Fundamentals”

[vegweb.com/composting/systems.shtml](http://vegweb.com/composting/systems.shtml)

“Garbage Disposals and Trimming Your Waste”

[www-erights.prod.consumerreports.org/cro/appliances/kitchen-appliances/garbage-disposers/garbage-disposers-204/overview/?resultIndex=10&resultPageIndex=1&searchTerm=traps](http://www-erights.prod.consumerreports.org/cro/appliances/kitchen-appliances/garbage-disposers/garbage-disposers-204/overview/?resultIndex=10&resultPageIndex=1&searchTerm=traps)

**Site****13. Maintain adequate slope and drainage away from building****Strategy included in: Major Addition**

To direct roof runoff and rainfall away from the foundation, grade the surrounding ground to maintain at least a 5% percent slope (six inches in ten feet) away from the foundation. While porous backfilling should be used along the foundation, a relatively impervious layer of soil near the surface will help to direct rainwater away from the house.

Another approach to manage bulk water load around the structure is to install a sub-surface “shed roof” (see Figure 16, page 14 in the reference cited below).

**Potential Issues:**

A 5% slope can be challenging, particularly given existing finish grade constraints. After surface water has been moved away from the structure, consider the advantages of on-site infiltration as opposed to stormwater system management of this load.

**Related Strategies:**

IDP1, IDP19, SS32

**References/Resources:**

“Read This Before You Design Build Or Renovate”

[www.buildingscienceconsulting.com/resources/mold/](http://www.buildingscienceconsulting.com/resources/mold/)

**14. Maintain adequate slope and drainage away from the house when creating outdoor living areas****Strategy included in: Outdoor Living**

The surface grade around a house is very important to prevent water (and winter snowmelt) from draining toward the house foundation, where it can cause moisture problems. With patios, decks, walkways, gazebos, and other outdoor living spaces and landscaping features be sure that a surface grade away from the house is maintained. Especially with patios that extend right up to the house, maintain a slight grade away from the house. If there are no gutters to collect rain off the roof, provide a different surface treatment at the roof dripline to minimize splashback into the house; a band of crushed stone with subsurface drainage away from the house is often a good option.

**Potential Issues:**

A 5% slope can be challenging, particularly given existing finish grade constraints.

**Related Strategies:**

IDP1, IDP19, SS32

**References/Resources:**

“Read This Before You Design Build Or Renovate”

[www.buildingscienceconsulting.com/resources/mold/](http://www.buildingscienceconsulting.com/resources/mold/)

**15. Design to support connection with nature****Included in: Outdoor Living**

Research into “biophilia” shows that views of, and contact with, nature can improve our health and wellbeing. Along with incorporating natural features outdoors, there are design features and decorations indoors that can help homeowners achieve a connection with nature. For starters, provide visual connection with the outdoors: large window areas facing natural features. Outdoors, provide patios, decks, or porches so that homeowners can enjoy outside living during good weather. Indoors, provide places for potted plants or even small indoor gardens. Decorate with art that represents or shows off relaxing natural scenes.

**Potential Issues:**

With indoor plantings and potted plants, be aware that mold, mildew, and insect pests can become problems, particularly if plantings are overwatered. On the other hand, these same natural features can be used to improve solar shading and even support bulk water management.

**Related Strategies:**

SS29, SS35, SS36, EA83, MR109

**References/Resources:**

“Biophilia in Practice: Buildings that Connect People with Nature,”

[www.buildinggreen.com/auth/article.cfm?fileName=150701a.xml](http://www.buildinggreen.com/auth/article.cfm?fileName=150701a.xml)

**Buildings for Life: Designing and Understanding the Human-Nature Connection**, Stephen Kellert, Island Press, 2005.

## 16. Design landscapes to encourage outdoor activities

### Strategy included in: Outdoor Living

The growing incidence of obesity among children is but one piece of evidence that children today are spending far less time outdoors. Landscapes around homes can be designed to encourage outdoor activities by people of all ages. Although conventional green lawns are not ecologically responsible, there are ways to create far greener lawns, as well as play surfaces covered with wood shavings or other safe surface materials.

### Potential Issues:

Green lawns provide an inherent tension with landscape design. On the one hand, conventional lawns are often chemical- and water-intensive and require pollution-spewing mowing. But their value as healthy play spaces (assuming few if any chemical additives), and their ability to infiltrate stormwater, can outweigh the negatives. A good compromise is often a modest lawn area in a landscape that includes more natural areas.

### Related Strategies:

SS34, SS35, SS38

### References/Resources:

*Last Child in the Woods*, Richard Louv  
[www.thefuturesedge.com](http://www.thefuturesedge.com)

## 17. Design landscape features to minimize heat island effects

### Strategy included in: Major Addition, Outdoor Living

The “urban heat island effect” refers to a localized warming that occurs in urban areas because of the large areas of dark surfaces absorbing solar energy. This not only increases air conditioning loads in urban areas but also exacerbates smog generation. Reflective (high-albedo) roofing materials and pavement surfaces, as well as vegetative plantings, can help to minimize this heat island effect. With roofing materials, look for products certified as Energy Star, which mandates a minimum reflectivity. With pavements, start by minimizing pavement area (minimizing driveway width, limiting parking area, etc.), but also look for lighter-colored paving materials, such as concrete grid-pavers instead of asphalt.

### Potential Issues:

This issue is of less concern in non-urban areas, particularly in cold climates.

### Related Strategies:

IDP3, SS30

### References/Resources:

“What Can Be Done?”  
[www.epa.gov/hiri/strategies/index.html](http://www.epa.gov/hiri/strategies/index.html)

## 18. Design to minimize outdoor water use

### Strategy included in: Outdoor Living

It is remarkable that Kentucky bluegrass and related turfgrass varieties are almost ubiquitous from coast to coast. We are designing landscapes in Phoenix and Las Vegas that require the same amount of water as landscapes in Connecticut and Seattle, Washington. A far more responsible (and affordable) approach is to design landscapes that are adapted to the local climate. In more arid or drought-prone areas, use xeriscaping (low-water-use landscaping). Where landscape irrigation is required, use water-conserving irrigation equipment (including drip-irrigation technology), advanced irrigation controls that will prevent overwatering (when the ground is already wet or when rainfall is expected), and consider innovative options such as graywater, harvested rainwater, or treated wastewater piped from sewage-treatment plants. Planting drought-tolerant landscapes, or providing alternative water sources, may enable landscape to remain healthy during drought and if outdoor watering restrictions are imposed.

### Potential Issues:

In some areas there are municipal regulations or subdivision covenants that mandate lawn watering. These can make responsible landscaping difficult.

### Related Strategies:

SS34, WE40

### References/Resources:

EPA WaterSense Program - [www.epa.gov/watersense](http://www.epa.gov/watersense)  
California Urban Water Conservation Council - [www.cuwcc.org](http://www.cuwcc.org)

## Foundation

## 19. Provide proper moisture control at footings, slab perimeter, and foundation walls

### Strategy included in: Major Addition

Foundations are one of the most significant moisture sources in many homes. Moisture can wick through concrete slab floors and foundation walls, then evaporate indoors—often with no visible wetness. Preventing moisture entry through the foundation requires proper foundation design, quality workmanship, and exterior drainage. Accepted foundation design for moisture control typically includes tamped, crushed stone under a foundation slab, a layer of durable polyethylene

(protected from abrasion with insulation or sand), a capillary break between the footing and foundation wall, a dampproofing layer on the foundation exterior, and a drainage layer on the outside of the foundation wall, including geofabric to keep silt out of the drainage layer and drainage pipe.

#### **Potential Issues:**

The addition foundation has to integrate with the existing foundation, both structurally and in terms of moisture management. Be prepared for the need to add perimeter foundation drainage to the existing structure if changes in surface and soil water movement change the performance of the existing foundation. Evaluate the benefits and risks of either.

#### **Related Strategies:**

IDP1, IDP25, IEQ163

#### **References/Resources:**

“Understanding Foundations”  
[www.buildingscienceconsulting.com/resources/foundations/Understanding\\_Foundations.pdf](http://www.buildingscienceconsulting.com/resources/foundations/Understanding_Foundations.pdf)

## **20. Upgrade basement floor**

### **Strategy included in: Basement**

A high performance basement floor manages bulk water, capillary water, and water vapor, while improving comfort in a basement living space. Floor insulation is not as much about reducing energy loss through the floor as it is about elevating the surface temperature for thermal comfort and lowering the relative humidity of the air boundary at the floor surface to manage dust mites, mold, and mildew. Unless you are replacing the existing basement concrete slab, or your basement does not have one, it is very likely that a capillary break and insulation will be needed on top of the existing basement slab. Here is what to look for and what to do:

**Wet floor** – if there is liquid water on your basement floor, you need to manage liquid water. Start by managing the site drainage. If exterior work gives access to the footing, install an exterior perimeter drainage systems that drains to daylight, a storm sewer, or a drywell. Otherwise, install an interior perimeter drainage system, sump pit, and pump.

**Damp floor** – If you see efflorescence (white powder on the surface of the basement slab), or if you conduct a Plastic Sheet test (ASTM D4263) and the plastic is wet on the side against the foundation wall, you may not need to manage liquid water, but you are going to have to do one of two things:

Make sure that anything and everything that you put on the basement floor is highly vapor permeable—that the whole assembly can dry to the interior.

Or, install a layer directly against the concrete floor that prevents all vapor transmission to the space above, and

that can manage water that condenses on its back side.

**Cast a new concrete slab** - If there is adequate headroom in the basement, moisture management and insulation can be accomplished by casting a new concrete slab on top of the existing. Provide a suitable moisture barrier, then a layer of insulation, then the concrete slab. Follow recommended practices for detailing the slab.

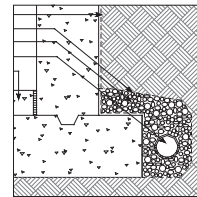
#### **Potential Issues:**

Moisture and radon exposure must be assessed, and a plan for their management developed, before any attempt can be made to convert a basement into living space. See the integrated pre-design issues for the basement.

Head height is a pretty common problem in finishing off a basement floor. One option is to dig out to gain the head height, which also provides the opportunity for improving moisture management and insulation of the basement slab.

#### **Details: Foundation Water Management**

- Crawl space foundation with piers
- Inside/outside perimeter drainage
- Inside/outside perimeter drainage with mat
- Inside perimeter drainage - retrofit



#### **Related Strategies:**

IDP1, IDP22, IDP25, IEQ179

#### **References/Resources:**

“Read This Before You Design Build Or Renovate”  
[www.buildingscienceconsulting.com/resources/mold/](http://www.buildingscienceconsulting.com/resources/mold/)

## **21. Upgrade exterior basement walls**

### **Strategy included in: Basement**

A high performance exterior foundation wall is well-drained, dampproofed, and well-insulated, and is constructed of durable materials that will not degrade, given the expected conditions. If the exterior surface of the existing foundation walls can be accessed, that is generally the best location for added insulation (bringing the thermal mass of the foundation wall into conditioned space), and provides a mechanism to manage moisture (keeping water out with a coating on the outside of the wall, free-draining material next to the wall, and perimeter drainage at the outside of the footer). See the strategy under major addition for constructing high performance new foundation walls.

Unfortunately, with most basement finishing projects, it is not possible to access the outside of the walls, so any modifications have to be done to the interior.

Here is what to look for and what to do:

**Wet walls** – If you see actual wetness, you need to manage liquid water. Assuming the outside of the foundation wall cannot be accessed through excavation, drainage has to be provided on the interior. Create a free-draining space to allow water to drain down the wall and into an internal drainage system at the perimeter of the basement floor; this should drain to an air-tight sump pit and pump.

**Damp walls** – If you see efflorescence (white powder on the surface of the masonry wall), or if you conduct a Plastic Sheet test (ASTM D4263) and the plastic is wet on the side against the foundation wall, moisture is likely seeping through the wall and evaporating on the interior. In this case, you can take one of two approaches:

Make sure that anything and everything that you put on the foundation walls is highly vapor permeable; that the whole assembly can dry to the interior.

Install a continuous water and vapor barrier facing a free-draining space next to the wall, and then make sure that every component of the basement assembly to the interior of this barrier is vapor permeable. This is particularly important if perimeter metal or wood stud walls are planned for the finished basement.

**Mud sill or rim joist moisture or rot** – If either the mud sill or rim joist at the top of the foundation wall is high in moisture content (above 18% in moisture content by weight) or actually degraded, you need to identify and eliminate the source of the problem. It could be improper site or building perimeter drainage, water wicking up into the wood assembly from its direct contact with the foundation wall, or condensation from a poorly insulated or air-sealed assembly. Replace compromised wood framing with non-toxic rot-resistant material such as TimberSil or wood-plastic composite materials that have the required design values and an Evaluation Service Report (ESR) number.

**Cold walls** – Insulate and air-seal, paying the most attention to the portion of the foundation wall that is above grade and the first four feet below grade. Air sealing details at the top of the wall and its transition to the wood framing assemblies above are critical, particularly if a free-draining air space is part of the new exterior wall finished assembly.

**Durable walls** – Use materials throughout your wall assembly that tolerate moisture and keep materials up and off materials that can wick moisture; this means capillary breaks between porous materials such as concrete, wood, and gypsum drywall. This will most likely entail upgrading to a high-performance basement floor *first* (See Upgrade basement floor) and then upgrading the basement walls.

**Avoid high interior relative humidity** – The best way to manage moisture is to keep it out, but in an existing

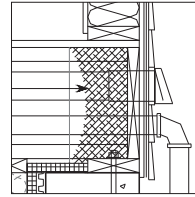
basement with walls drying to the interior, you are very likely going to need to manage it from the inside with active dehumidification. See basement HVAC strategy.

#### **Potential Issues:**

Moisture and radon exposure must be assessed and managed before any attempt can be made to convert a basement into living space. See the integrated pre-design issues for the basement.

Paper-faced interior sheathing products should in general be avoided in basement wall assemblies.

#### **Detail: Basement Moisture and Energy Management**



#### **Related Strategies:**

IDP1, IDP19, IDP22, IDP25, IEQ183

#### **References/Resources:**

“Read This Before You Design Build Or Renovate”  
[www.buildingscienceconsulting.com/resources/mold/](http://www.buildingscienceconsulting.com/resources/mold/)

## **22. Include capillary break between all concrete and sill plates**

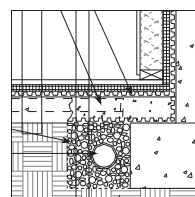
### **Strategy included in: Basement, Major Addition**

It is becoming common practice for closed-cell foam sill sealer or similar material to be installed between all concrete and framing on exterior foundation walls (usually purposefully as an air sealing detail and incidentally as a capillary break). But just as this material serves as a capillary break on exterior walls, it does the same for *interior* walls. To keep capillary water from rising into interior framing, a capillary break material is needed between all bottom plates and concrete foundation walls or floors.

#### **Potential Issues:**

Some minor adjustments in stud lengths may be necessary to have interior walls with sill sealer line up properly with existing exterior wall heights. It is possible to raise and brace exterior walls to insert a sill sealer/capillary break material, but the moisture flow potential from foundation to exterior above-grade wall must be assessed in terms of the cost of such a strategy.

#### **Detail: Basement Moisture and Energy Management**





## Related Strategies:

IDP1, EA47

## References/Resources:

“Read This Before You Design Build Or Renovate”

[www.buildingscienceconsulting.com/resources/mold/Read\\_This\\_Before\\_You\\_Design\\_Build\\_or\\_Renovate.pdf](http://www.buildingscienceconsulting.com/resources/mold/Read_This_Before_You_Design_Build_or_Renovate.pdf)

## 23. Provide appropriate insect control

### Strategy included in: Major Addition

The foundation provides the interface between the ground and the house, and this is the most common point of entry of wood-destroying insects, especially subterranean termites, though carpenter ants and powderpost beetles can also be problems. Keep all untreated wood 12 inches above soil (most building codes require 8 inches), and keep vegetation at least two feet from foundation walls. A variety of strategies can be used to manage the threat posed by insects: non-wood building systems, metal shields or screens, sand barriers, borate or sodium silicate-treated wood, and newer bait management systems.

### Potential Issues:

Some jurisdictions still require chemical treatments around houses for termite control. If this is the case, use the least-toxic chemicals available. The use of exterior foam insulation on foundation systems can require both inspection zones and metal shields depending on the intensity of the insect risk exposure.

### Image: Borate Insect Treatment of Framing



## Related Strategies:

IDP1, EA47

## References/Resources:

Integrated Pest Management (IPM) Practitioners Association  
[www.efn.org/~ipmpa/keydocs.html](http://www.efn.org/~ipmpa/keydocs.html)

*Common Sense Pest Control*, William Olkowski, Shiela Daar, Helga Olkowski, Taunton Press, 1991

Bio-Integral Resource Center - [www.birc.org](http://www.birc.org)

## Building Envelope

## 24. Provide proper moisture management strategies

### Strategy included in: Major Addition, Gut Rehab, Deep Energy Retrofit

Keeping moisture out of a house is critical to ensuring

its long-term durability, particularly in wetter climates. Many of the strategies required for moisture management involve the building envelope. These include providing a substantial roof overhang, ensuring that window and door flashing is properly installed, sealing any roof and wall penetrations including chimneys and vent stacks, providing a house-wrap weather barrier or asphalt-impregnated paper (tar paper), providing a rainscreen detail (an air space behind siding that provides a drainage plane and allows siding to dry off between wettings), provide an air barrier in the insulated envelope (on the interior and/or the exterior), and selecting both interior and exterior finishes that fit the vapor profile. (Note that vapor diffusion and bulk water movement are quite different; a material that blocks bulk water movement might or might not retard moisture diffusion.)

### Potential Issues:

The key, particularly in remodeling, is to manage energy and moisture with equal intensity. Heat flow dries assemblies out, and decreasing the heat flow through an assembly (with insulation and air sealing) requires superior moisture management. A wall that tolerated a small leak under a window may fail when that same amount of moisture no longer dries out because of upgraded insulation and air sealing.

Penetrations into existing walls and roofs raises the issue of just how flashing systems for the penetrations will properly function if the existing assemblies do not have weather-resistive barriers in place. Consider removing enough exterior cladding to integrate a new penetration with the assembly.

## Related Strategies:

IDP1, IDP3, IDP25, IDP27

## References/Resources:

“Read This Before You Design Build Or Renovate”

[www.buildingscienceconsulting.com/resources/mold/Read\\_This\\_Before\\_You\\_Design\\_Build\\_or\\_Renovate.pdf](http://www.buildingscienceconsulting.com/resources/mold/Read_This_Before_You_Design_Build_or_Renovate.pdf)

## 25. Assess vapor profile of new assemblies

### Strategy included in: Basement, Home Performance, Major Addition, Gut Rehab, Deep Energy Retrofit

There is a long-standing tradition in building to focus on the vapor permeability of just one component in building assemblies—that of the “vapor retarder” or “vapor barrier.” But ALL of the components in an assembly, both individually and collectively, determine how water vapor moves or does not move through an assembly. The relative vapor permeability of ALL components in an assembly should be assessed, and the designer should ensure that there is at least one, if not two, paths for drying (drying potential to the interior, the exterior, or both). This aspect of assembly moisture performance is called the “vapor profile.” In other words,

how an assembly is designed to dry is just as important as how it is designed to keep from getting wet. This is particularly important when a portion of the wall, roof, or foundation assembly already exists and new components are being added. Vapor profiles are also important to consider when closed cavity insulation fill is used to upgrade the thermal performance of wall and roof assemblies.

**Potential Issues:**

Elements of building assemblies are selected for more than just their vapor permeability. This one property must be balanced with many other considerations, such as flammability, thermal conductivity, ease of installation, long-term durability, cost, appearance, etc. The builder, architect, and specifier should all be aware of exactly why each component of an assembly has been selected and not make substitutions without a reassessment of the impact any substitution has on the overall performance of the assembly, including the vapor profile.

In general, avoid components with very low vapor permeabilities UNLESS there is a vapor drive threat based on climate and an assembly that requires it. Examples include vapor retarders with a vapor permeability less than 1 perm in very cold climates and average interior relative humidity greater than 30%, or brick veneer walls where solar-driven moisture is likely.

**Image: Drip-Through Deck Grating on Gutterless Eaves**



**Related Strategies:**

IDP1, IDP3, EA48, EA49, MR129, IEQ184

**References/Resources:**

"Understanding Vapor Barriers"  
[www.buildingscience.com/documents/digests/bsd-106-understanding-vapor-barriers?topic=/designguidance/buildingscienceanddesign/enclosureprinciples/main\\_topic](http://www.buildingscience.com/documents/digests/bsd-106-understanding-vapor-barriers?topic=/designguidance/buildingscienceanddesign/enclosureprinciples/main_topic)

**26. Properly detail window sills in wet areas**

**Strategy included in: Bathroom**

A tub or shower surround is a really tough place to put a window, (though there are plenty of them in both new and existing homes), and it can be hard to balance the aesthetic and daylighting gains with moisture management challenges. If a window of any kind either must stay or go into the wet area of the tub or shower surround, it has to be detailed per the drawing below.

Most importantly:

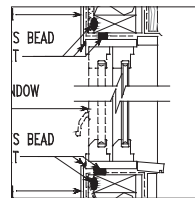
- The sill must be water impermeable, such as marble or a Corian-like material—not tiled with grout joints unless the grout is epoxy-based.
- The sill must be pan-flashed/sealed as if it were an exterior sill. (Two people taking one shower each day for 8 minutes is equivalent to approximately 1,000 inches of driving rain a year!)
- Select more moisture tolerant frame material, such as vinyl or fiberglass, not wood or metal-clad.

**Potential Issues:**

This is a really tough detail; if at all possible, keep windows and skylights out of the tub/shower surround.

**Details: "Wet Room" Window**

- High sill shower window
- Low sill shower window



**Related Strategies:**

IDP1, IDP24

**References/Resources:** See accompanying details.

**27. Ensure that window and skylight installations include proper air sealing and flashing**

**Strategy included in: Bathroom, Deep Energy Retrofit**

Water and air leakage problems at windows and skylights are all-too-common and cause a multitude of structural and indoor air quality problems. Water leaks can be highly damaging and very expensive to remodeling contractors—not to mention inconvenient with weekend call-backs. Air leaks can result in significant heat loss, costing homeowners hundreds of dollars per year. Follow practices recommended by building scientists to properly flash and seal all wall and roof penetrations.

**Potential Issues:**

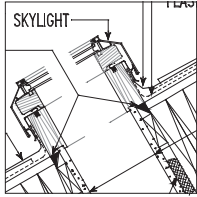
If the existing roof or wall assembly has no weather-resistant barrier (concealed drainage plane), how do you integrate the flashing of the new unit to the existing exterior of the assembly? Without a weatherlap, the unit flashing will do little to protect the overall assembly. If this assembly is not significantly protected by an overhang or roof, consideration may have to be given to stripping the exterior cladding so that a true weatherlapped flashing approach can be achieved.

Also, while skylights and roof windows can add important daylight to homes, keep in mind that they can

be significant sources of unwanted solar heat gain. Hire an energy designer or mechanical engineer to carry out computer modeling to determine the optimal size and location of skylights.

### Details: Bay Window and Skylight Air Sealing/Insulation

- Air sealing at bay window
- Air sealing at skylight head and sill
- Air sealing at skylight jamb



### Related Strategies:

IDP1, IDP24, EA54

**References/Resources:** See accompanying detail.

## 28. Properly detail connection between deck and house

### Strategy included in: Outdoor Living, Major Addition

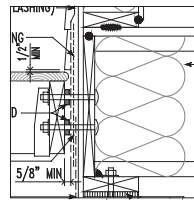
The connection between a house and deck is critically important relative to structural stability and long-term moisture management and durability. Improperly detailed, the deck connection can channel water into the ledger plate and rim joists of the house, causing rot, which in turn can weaken the deck connection to the house, risking catastrophic failure. Additionally, the copper-based preserved wood that have largely replaced CCA (chromated copper arsenate) are corrosive to steel; special fasteners must be used to reduce risk of failure. The detail below shows proper flashing for connections for a deck that should help to ensure a long life both for the deck and the house.

### Potential Issues

A deck is a significant investment in materials; consideration should be given to whether the functions of a deck can be provided with another outdoor living space option, such as a patio.

The shear forces exerted on the fasteners with free space between the deck ledger and existing structure may require engineered or strength specified fasteners. An alternative approach would be to have the deck ledger bear on posts so that the deck/house fasteners are only facing tear-out and not shear forces.

### Detail: Deck Attachment at Band Joist



### Related Strategies:

IDP1, IDP24, MR110, MR111, MR112

### References/Resources:

“Deck2 Wall Spacer”

[www.screw-products.com/deck2wallspacer.htm](http://www.screw-products.com/deck2wallspacer.htm)

## Sustainable Sites (SS)

### Site

### 29. Minimize site disturbance

#### Strategy included in: Major Addition, Gut Rehab, Deep Energy Retrofit, Outdoor Living

With any addition there will be site disturbance, but through careful planning and job-site supervision, that disturbance can be kept to a minimum. Carefully control the impact area of a job site by designating vehicle parking further from the site and storing building materials inside a garage or other protected area. Existing trees should be protected by fencing off an area that includes, at a minimum, the “drip line” of those trees (a line extending down from the outermost perimeter of the trees’ branches); it is important not only to avoid direct damage to tree trunks, but also to avoid compaction of soil around trees by construction vehicles or storage of materials, which can smother tree roots. On undisturbed sites, efforts should be taken to protect native vegetation, which, depending on the region, may include woodland wildflowers, prairie meadows, or arid xeriscapes. Consider providing incentives for excavation contractors to protect the site (or penalties for damage). Where damage will be unavoidable, existing plants can be dug up and relocated. Best practices should be followed to control erosion of topsoil from the site, including—as needed—silt fencing, berming, wood chip entry pads, and use of straw bales to filter runoff. Ensure that equipment being used by excavation contractors is not leaking fuel or hydraulic fluid.

### Potential Issues:

Many remodeling job sites are tight spaces that require careful planning to keep materials moving on and off the site easily without the actual site materials moving off the site as well! Minimizing site disturbance starts with project planning and then translates into sound job site management.

### Related Strategies:

SS39

### References/Resources:

“The Low Risk Site Handbook for Erosion Prevention and Sediment Control”  
[www.vtwaterquality.org/stormwater/docs/construction/sw\\_low\\_risk\\_site\\_handbook.pdf](http://www.vtwaterquality.org/stormwater/docs/construction/sw_low_risk_site_handbook.pdf)

Erosion Control Technology Council - [www.ectc.org](http://www.ectc.org)

## 30. Make use of trees and landscaping to reduce cooling loads

### Strategy included in: Major Addition, Outdoor Living

Shade trees can dramatically reduce cooling loads in houses or additions. Efforts should be made to protect trees that are already present and new trees should be planted to provide future shading and protection. On the south side of a house where passive solar heating is being used, tall deciduous trees can allow the low wintertime sunlight to reach south-facing windows and solar features, yet block the summer sun, which is higher in the sky. On west walls, it may make sense to incorporate trellises, arbors, and planting beds for tall annuals to provide shading of west-facing windows (where summertime heat gain is the biggest problem).

### Potential Issues:

In arid areas—where shading can be most beneficial—the moisture requirements for trees may be significant; select trees that are adapted to the climate and will require a minimum amount of irrigation.

In temperate regions, deciduous trees can provide summertime shading and then solar access during the winter when they drop their leaves. Care must be taken in selecting deciduous trees, however, because they vary widely in the amount of shading that bare branches achieve.

### Related Strategies:

IDP3, SS31

### References/Resources:

“Conserving Energy with Landscaping”  
[www.ext.vt.edu/pubs/envirohort/426-712/426-712.html](http://www.ext.vt.edu/pubs/envirohort/426-712/426-712.html)

## 31. Modify landscaping to provide solar access

### Strategy included in: Major Addition, Outdoor Living

To provide solar access to a house, it is often necessary to remove or prune trees on the south, east, or west. A solar site assessment tool can be invaluable in identifying trees that should be removed or pruned. Removing trees from immediately around a house can also help with air circulation, which can improve durability.

### Potential Issues:

Removing these trees from around a house to provide solar access can increase cooling loads.

### Related Strategies:

IDP3, SS30, EA100, EA101, EA102

### References/Resources:

“Conserving Energy with Landscaping”  
[www.ext.vt.edu/pubs/envirohort/426-712/426-712.html](http://www.ext.vt.edu/pubs/envirohort/426-712/426-712.html)

“Passive Solar Home Design”  
[www.eere.energy.gov/consumer/your\\_home/](http://www.eere.energy.gov/consumer/your_home/)

## 32. Minimize contiguous impervious surfaces and facilitate infiltration

### Strategy included in: Major Addition, Outdoor Living

Runoff from roofs, sidewalks, driveways, and other impervious surfaces can contaminate surface waters (streams, rivers, estuaries, etc.) and lead to downstream flooding and erosion. Far better, from an environmental standpoint, is allowing that stormwater to soak into the ground where it can recharge underground aquifers. To maximize infiltration and limit runoff, try to avoid impervious surfaces outdoors, limit contiguous impervious surfaces (in other words, provide permeable drainage areas between sidewalk and other impervious surfaces), use porous paving materials (open-matrix concrete grid pavers, specialized honeycomb substrates for gravel or turf, or pervious mixes of concrete or asphalt), and provide vegetated infiltration swales, rainwater gardens, or other landscape features where stormwater can collect and infiltrate.

### Potential Issues:

Porous paving requires specialized management; in northern climates, for example, applying sand or salt in winter can clog the pores in these surfaces.

On-site stormwater management can be something for which local jurisdictions have specific policies. Make sure that whatever strategies you employ to keep water on site comply with local stormwater management policies and regulations.

### Related Strategies:

IPD1, IDP24, SS39

### References/Resources:

“EPA Stormwater Best Management Practice Design Guide”  
[www.epa.gov/ORD/NRMRL/pubs/600r04121/600r04121a.pdf](http://www.epa.gov/ORD/NRMRL/pubs/600r04121/600r04121a.pdf)

## 33. Provide porous pavement

### Strategy included in: Outdoor Living

Whenever we can design outdoor surfaces around buildings to allow rainwater to infiltrate the ground rather than running off and being collected in storm sewers, we accomplish several important benefits: we



help to recharge underground aquifers; we reduce contamination of surface waters with pollutants that are picked up in stormwater runoff; we reduce risk and frequency of downstream flooding, and (in many urban areas) we reduce combined sewage overflow (CSO) events in which sewage treatment plant capacity is overwhelmed during storms and raw sewage ends up getting dumped into surface waters without treatment. Porous pavement around houses is one important way to increase onsite infiltration. Options include porous grid pavers, pervious concrete, porous asphalt, and specialized turf and gravel systems in which a matrix supports these porous materials and prevents vehicles from compacting the ground surface. Porous pavements should be considered for driveways, walkways, pathways, sidewalks, patios, and emergency-access alleys.

#### **Potential Issues:**

Porous pavements often require more maintenance than impervious surfaces, because plants are able to grow through such surfaces. In cold climates where snow and ice removal is required, porous pavements may become clogged with sand or damaged by plowing.

#### **Related Strategies:**

SS32, MR109

#### **References/Resources:**

*Porous Pavements*, Bruce Ferguson, CRC Press, 2005  
[www.buildinggreen.com/biblio/item.cfm?itemID=1362](http://www.buildinggreen.com/biblio/item.cfm?itemID=1362)  
Center for Watershed Protection - [www.cwp.org/](http://www.cwp.org/)  
"Permeable Pavement"  
[toolbase.org/Technology-Inventory/Sitework/permeable-pavement](http://toolbase.org/Technology-Inventory/Sitework/permeable-pavement)

### **34. Reduce lawn area**

#### **Strategy included in: Outdoor Living**

Conventional lawns carry significant environmental burdens, including chemical applications (fertilizers, herbicides, and pesticides), irrigation in many parts of the country, run-off and resulting sewage treatment burden, and the need for regular mowing (which emits far more air pollution per unit of gasoline burned than driving cars). Increasingly, homeowners wanting to minimize environmental impacts (and save money) are figuring out ways to minimize lawn area, replacing it with naturalized woodlands, wildlife habitat, small meadows with native plants, and in arid areas, xeriscapes with cacti and other desert plants that require little or no added water. When outdoor living spaces and landscape features are being considered, address with homeowners whether there are opportunities to reduce lawn area—and address how such landscaping can be integrated into outdoor living features.

#### **Potential Issues:**

The cost of converting lawn to native plant habitat can be significant, but the costs of maintaining natural habitat is typically lower than the costs of maintaining lawns. Lawns are better than pavement in terms of heat island effects and so better to “grass” than “pave” if other more sustainable site coverage options can not be employed.

#### **Related Strategies:**

SS35, SS37

#### **References/Resources:**

*How to Get Your Lawn Off Grass*, Carole Rubin, Sally Wasowski, and Lorraine Johnson, Harbour Publishing, 2002  
“Reducing Lawn Area”  
[www.recycleworks.org/greenbuilding/sus\\_lawnarea.html](http://www.recycleworks.org/greenbuilding/sus_lawnarea.html)

### **35. Provide wildlife habitat**

#### **Strategy included in: Outdoor Living**

Certain plantings can attract birds, butterflies, and other wildlife, helping to support local biodiversity and ecological balance, while also providing enjoyment to homeowners. Look for native plants that are adapted to the area and will not require irrigation—or risk contributing to the invasive species problems that plague landscapes today.

#### **Potential Issues:**

Some fruit-bearing plants can cause track-in problems in homes. Use care in plant selection and location of plantings to avoid tracking in berries or fruits on shoes, which can increase cleaning needs.

#### **Related Strategies:**

IEQ161

#### **References/Resources:**

National Wildlife Federation Wildlife Habitat Program - [www.nwf.org/backyard/](http://www.nwf.org/backyard/)  
*Welcoming Wildlife to the Garden*, Catherine J. Johnson, Susan McDiarmid, Edward R. Turner Hartley and Marks Publishers 2004  
*The Natural Habitat Garden*, Kenneth Druse, TimberPress, 2004

### **36. Use landscape features to shield the house**

#### **Strategy included in: Major Addition, Outdoor Living**

Noise, street lighting, commotion from neighbors, unpleasant views, wind, and excessive sunlight can be problems at some houses. Landscaping features, including earthen berms, walls, and plantings can provide important shielding. Work with landscape architects or landscape contractors to figure out solutions to provide such shielding when it's needed.

#### **Potential Issues:**

Shade tree plantings can severely reduce the potential

to benefit from passive solar heating and daylighting. Consider the impact of various deciduous trees versus evergreens when balancing passive solar with shading strategies, given that deciduous trees vary significantly in their bare branch shading percentage.

**Related Strategies:**

IDP3

**References/Resources:**

*Site Planning for Solar Access: A Guide to Residential Developers and Builders*, Erley and Jaffe, DIANE Publishing, 1997

### 37. Provide for edible plants in the landscape design

**Strategy included in: Outdoor Living**

When topography and sun exposure allows, consider planting edible plants instead of or in addition to decorative ones. Locally grown food is usually healthier than store-bought produce, and the transportation energy use in getting produce onto your table is greatly reduced. Growing one's own provides a high level of personal satisfaction and supports a greener lifestyle.

**Potential Issues:**

While home-grown vegetables and fruits can be safer and healthier than store-bought produce, heavy use of pesticides, fertilizers, and irrigation can eliminate those health benefits and increase local environmental burdens. Be aware that soils on some sites have been previously damaged by heavy chemical use.

**Related Strategies:**

IDP6

**References/Resources:**

National Gardening Association - [www.garden.org/ediblelandscaping/](http://www.garden.org/ediblelandscaping/)

Edible Landscaping and Gardening - [www.efn.org/~bsharvy/edible.html](http://www.efn.org/~bsharvy/edible.html)

### 38. Landscape to minimize chemical use

**Strategy included in: Outdoor Living**

Conventional lawns in many parts of North America require heavy applications of fertilizers, pesticides, and herbicides (as well as irrigation water and regular mowing). Low-maintenance turf grasses are available for many regions, including buffalo grass for dry, sunny applications and native fescues for cooler, cloudier locations. Beyond turf, there are many native landscaping practices that are far more environmentally responsible. Locally adapted prairie plants, woodland flowers, trees, and dryland succulents and cactuses all make sense in certain climates. When conventional lawns are required, select a seed mix that will be as hardy as possible and require minimal additives.

**Potential Issues:**

Native landscapes are more difficult to establish—though they are usually less expensive to maintain.

**Related Strategies:**

SS34

**References/Resources:**

Washington Toxics Coalition - [www.watoxics.org/homes-and-gardens](http://www.watoxics.org/homes-and-gardens)

### 39. Use site-chipped/ground clean wood waste as erosion control

**Strategy included in: Major Addition, Gut Rehab, Deep Energy Retrofit**

Chipped or ground clean wood waste can be put in woven “socks” and placed as a drive pad at site entrances to reduce soil erosion and keep dirt on the job site as opposed to the streets and sewers.

**Potential Issues:**

Clean wood waste means no pressure-treated, wood-composite, or wood materials laminated with non-wood material. Check to make sure that local regulations permit the use of engineered wood waste for mulching and soil erosion control.

**Image: Clean Wood Waste for Site Erosion Control**



**Related Strategies:**

SS32, MR107

**References/Resources:**

“Toolbase Construction Waste” [www.toolbase.org](http://www.toolbase.org)

“Construction Waste Management for Residential Builders and Sub-Contractors” [www.packer2000.com/](http://www.packer2000.com/) (click on “Residential”)

## Water Efficiency (WE)

### Site

### 40. Provide rainwater collection system

**Strategy included in: Outdoor Living**

Capturing rainwater from the roof for landscape irrigation makes a great deal of sense in areas where water is—or may become—limited. A very simple rainwater harvesting system consists of a rain barrel positioned at

the corner of a house into which the roof downspout flows. Rainwater is collected in gutters and directed to the downspout, which channels that water into the rain barrel. A hose feeding from the base of the barrel is used for landscape watering. More sophisticated rainwater harvesting systems can provide filtration and purification so that water can be used indoors, even for drinking. The storage tank (whether a simple barrel or large cistern) should be covered to keep out animals, children, and sunlight.

**Potential Issues:**

The quality of the water harvested can be highly variable, largely depending on the type of roofing material. The system generally must be covered to prevent the water storage becoming mosquito habitat. Some local jurisdictions/water districts do not permit on-site collection of rainwater; check with local authorities to determine the legality of your rainwater harvesting plans.

**Related Strategies:**

SS37

**References/Resources:**

The Rainwater Harvesting Community - [www.harvesth2o.com](http://www.harvesth2o.com)

## Plumbing

### 41. Install low-water-use kitchen faucet

**Strategy included in: Kitchen**

Standard kitchen faucets have a flow rate of 2.5 gallons per minute (gpm). This can be reduced with a low-flow faucet aerator to 2.0 or 1.5 gpm, but low flow rates may be frustrating in a kitchen because of the need to fill pots. Often more practical are devices to control the water flow such as flip-type aerators that allow the user to quickly cut the water flow without altering the hot-cold mix.

Another option is a hands-free faucet control. Foot or knee and photo-electric controls allow the user to turn on the water only when needed, reducing waste. Although fairly expensive upgrades, both options offer convenience and water/energy savings.

**Potential Issues:**

Savings from user-activated faucet controls have not been substantiated to date. Because kitchen faucet water consumption is fairly insignificant relative to a home's overall water use, kitchen faucet water efficiency is a relatively low priority.

**Related Strategies:**

IDP6

**References/Resources:**

[www.epa.gov/watersense/](http://www.epa.gov/watersense/)  
[www.h2ouse.org/](http://www.h2ouse.org/)

### 42. Replace toilets with high-efficiency toilets

**Strategy included in: Bathroom**

In most existing homes, toilet flushing is the single largest water user. The older the existing toilets, the more important their replacement with new, water-efficient models. Federal law mandates that new toilets can use no more than 1.6 gallons per flush (gpf), while many older toilets use 3.5 gpf and even as much as 7 gpf. There are now dozens of toilets on the market that offer superb flush performance, yet use at least 20% less water than 1.6 gpf models; these are called high-efficiency toilets (HETs). Included here are pressure-assist toilets that use as little as 1.0 gpf, gravity-flush toilets that consume 1.28 gpf, and dual-flush toilets that offer two different flush volumes (depending on whether solid or liquid wastes are being flushed). Dual-flush toilets are now required by law in Australia and very common throughout Europe. To ensure that a toilet will provide satisfactory flush performance, chose a model that has been put through third-party MaP (Maximum Performance) testing and is rated in grams; look for MaP test results of 350 grams or higher or toilets that meet the new EPA WaterSense program requirements.

Composting toilets may also be an option for major addition projects.

**Potential Issues:**

Federal law on low flow toilets only applies to the manufacture of new toilets so be careful not to re-install a toilet that uses more than 1.6 gpf or to purchase what appears to be an attractive salvaged toilet that uses more than 1.6 gpf. Techniques that reduce water use in these older units (bricks or dams in the toilet tank) can be problematic because the unit is not getting the volume during the flush for which it was designed.

When the 1.6 gpf federal standard was introduced in 1994, many manufacturers simply modified the flush valve to reduce the flush volume without modifying the toilet bowl and drain line; this resulted in poor performance, giving low-flush toilets a bad reputation. Today's EPA WaterSense-approved models pass a flush performance test that has proven to be a good measure of overall performance

Older, less efficient toilets should be recycled but recycling outlets for toilets are not available in all areas of the country.

**Related Strategies:**

IDP6

**References/Resources:**

EPA Water Sense Program - [www.epa.gov/watersense/pp/het.htm](http://www.epa.gov/watersense/pp/het.htm)  
California Urban Water Conservation Council - [www.cuwcc.org](http://www.cuwcc.org)

“Toilet Recycling”  
[www.h2ouse.org/tour/bath.cfm](http://www.h2ouse.org/tour/bath.cfm) (click on "Toilet", then on "Disposal & Recycling")  
“Composting Toilets”  
[www.cityfarmer.org/comptoilet64.html](http://www.cityfarmer.org/comptoilet64.html)

### 43. Install low-water-use showerheads

#### Strategy included in: Bathroom

Older showerheads often use three to five gallons per minute (gpm), while federal law now requires that new showerheads can use no more than 2.5 gpm. For a green bathroom remodel, choose a showerhead that uses less than the 2.5 gpm maximum; excellent showerheads are available that use as little as 1.5 gpm and deliver a very satisfactory shower. Note that many of the early low-flow showerheads atomized the water into a fine mist that resulted in very unsatisfactory showers—both because the tiny droplets did not effectively wet the skin and because the droplets cooled off quickly, so the shower felt cool (or the water had to be set at a higher temperature). Better-quality showerheads today maintain large droplet size to provide satisfactory wetting and heat retention, yet use significantly less water.

There may be no substitute to the personal test for low-flow showerheads. While EPA is working with private industry to establish a performance-based test for low-flow showerheads, it will be a while before this comes to fruition, particularly since anecdotal results on low-flow showerheads as part of the EPA Residential Water Efficiency Benchmarking study show completely different preferences for the same two models when tested by builders and their staff in the study. Consideration should be given to showerheads mounted on a sliding arm since the distance between the showerhead and the individual is proving to be a significant determinant of shower experience satisfaction, particularly at lower flow rates.

#### Potential Issues:

There is a growing trend to install custom shower systems that have multiple showerheads or rain-panel components that result in total water consumption far above the 2.5 gpm limit for single showerheads. Some use as much as 20 gpm and require two drains in the floor. Avoid the temptation to install these wasteful systems!

#### Related Strategies:

IDP6

#### References/Resources:

EPA Water Sense Program -  
[www.epa.gov/watersense/pp/showerheads.htm](http://www.epa.gov/watersense/pp/showerheads.htm)  
REGREEN Product Selection Resources -  
[www.regreenprogram.org](http://www.regreenprogram.org)  
(Also, type in “adjustable height showerheads” into any web browser)

### 44. Install water-conserving bathroom faucet aerator

#### Strategy included in: Bathroom

While kitchen faucets usually need to deliver fairly close to the allowable 2.5 gallons per minute (gpm) of water—to fill pots for example—bathroom faucets often do not. In many homes, 1.0 gpm or even as little as 0.5 gpm is adequate for washing hands, brushing teeth, shaving, etc. Simple screw-on aerators are available that reduce flow to the desired level. Determine with the homeowners what flow rate is desired and specify the proper aerator; the aerators are inexpensive and can easily be swapped out later if the flow rate seems either higher or lower than desired.

#### Potential Issues:

The lower the flow rate of a faucet, the longer it will take to get hot water at the tap. For example, with a flow rate of 0.5 gpm, ¾" copper piping, and 50 feet of distance from the water heater, it can take more than 2.5 minutes to get hot water, while with a 1.5 gpm faucet, the wait time will be less than a minute. There are other ways to deal with the wait time (see Related Strategies), but if it is not dealt with, a very low-flow faucet may prove unsatisfactory.

#### Related Strategies:

IDP6

#### References/Resources:

EPA Water Sense Program -  
[www.epa.gov/watersense/pp/bathroom\\_faucets.htm](http://www.epa.gov/watersense/pp/bathroom_faucets.htm)

## Energy and Atmosphere (EA)

### General Design and Construction Strategies

### 45. Use computer modeling to determine heating and cooling loads

#### Strategy included in: Home Performance, Major Addition, Gut Rehab, Deep Energy Retrofit

To properly size and optimize the performance of heating, ventilation, and air conditioning equipment in conjunction with building envelope performance, computer modeling is very important. When the house envelope is being buttoned up, an addition is adding to the total square footage of the house, or mechanical equipment is being upgraded, it is very important to understand the heating, air conditioning (and sometimes ventilation) loads fairly precisely, and only computer simulation can provide such estimations. Through careful computer modeling, mechanical equipment can be



properly sized, avoiding the inefficiencies (and higher pollution) that result from frequent on-off cycling of equipment.

#### **Potential Issues:**

Occupant behavior has a huge impact on actual energy usage in any home. Clear communication and a homeowner's manual can go a long way toward ensuring that the house will be managed for the optimal energy performance designed and built into the project

#### **Images: Retrofit Insulation Strategies**

- **Interior Rigid Insulation (taped seams for air seal) on Walls**
- **Interior Rigid Insulation and Air Sealed (taped seams) on Ceiling**
- **Exterior Wall Air Sealed and Insulated with Spray Foam, Reclad**
- **Exterior Wall Spray Foam Insulation**



#### **Related Strategies:**

IDP2, IDP3, EA51, EA63

#### **References/Resources:**

REMRate - [www.archenergy.com/products/rem/](http://www.archenergy.com/products/rem/)  
TREAT - [www.treatsoftware.com/treat\\_intro.html](http://www.treatsoftware.com/treat_intro.html)  
Energy-10 - [www.sbicouncil.org/store/e10.php](http://www.sbicouncil.org/store/e10.php)

## **46. Evaluate different heat distribution options**

### **Strategy included in: Major Addition, Deep Energy Retrofit**

While some house additions necessitate expansion of the heat and air conditioning distribution systems, building envelope improvements often allow the distribution systems—as well as the heating and cooling equipment—to be downsized or reconfigured to more efficient, centralized and simplified systems. With very significant improvements to the envelope, in fact, it may be possible to totally eliminate central distribution systems and rely instead on simple space heating and space cooling equipment. A space heating system could be short sections of baseboard electric resistance heat (the lowest first-cost option), a through-the-wall-vented gas wall heater or visible-flame gas fireplace, or a wood stove or pellet stove. Room air conditioners or mini-split air conditioners can provide space cooling.

Along with sizing of heat loads and the potential to shrink or eliminate distribution systems, also consider

how the same forced-air distribution system can be used for multiple needs in a highly energy-efficient house. Typically, larger ducting is required for air conditioning than for space heating, and both of these needs are greater than for ventilation, but by significantly shrinking the heating and cooling loads it is often possible to have one duct system serve all three needs; hire a knowledgeable mechanical engineer to address this issue.

With both forced-air and hot-water (hydronic) distribution systems, carefully plan where they will be installed and whether they should be insulated. Try to avoid running any distribution lines outside of the conditioned building envelope. If any distribution components are in unconditioned or partially conditioned space, provide high-quality, durable insulation appropriate to the pipes or ducts. All ducting should be sealed with duct mastic to minimize losses, and ducts should be pressure tested as part of the commissioning process (using a Duct Blaster or comparable equipment) to test for leaks.

#### **Potential Issues:**

The idea of eliminating distributed heat or air conditioning will find natural resistance. If pursuing this strategy, use computer modeling to demonstrate that the space heating alternatives proposed will indeed do the job.

#### **Related Strategies:**

IDP3, EA66

#### **References/Resources:**

REMRate - [www.archenergy.com/products/rem/](http://www.archenergy.com/products/rem/)  
TREAT - [www.treatsoftware.com/treat\\_intro.html](http://www.treatsoftware.com/treat_intro.html)  
Energy-10 - [www.sbicouncil.org/store/e10.php](http://www.sbicouncil.org/store/e10.php)

## **Foundation**

### **47. Insulate floor slab and foundation walls**

#### **Strategy included in: Major Addition**

In most climates, foundation walls should be insulated. The most common insulation for foundation walls is extruded polystyrene (XPS), though high-density (minimum 1.5 pounds per cubic foot) expanded polystyrene (EPS) can also be used, as can rigid mineral wool or rigid fiberglass. Computer modeling should be used to determine appropriate insulation levels. Foundation walls can also be insulated on the interior, as long as proper care is taken to deal with moisture management. On the interior, if basement space is to be finished, a wall-system is built and insulated with sprayed polyurethane (closed-cell or open-cell), or a fiber insulation such as fiberglass, mineral wool, or cellulose. Insulated concrete forms (ICFs) and insulated pre-cast concrete wall systems provide integral insulation. With slab-on-grade applications and basement floor slabs

(when the basement is to be finished and heated), it is important to also insulate under the slab.

#### **Potential Issues:**

Proper moisture control is critically important with interior insulation of foundation walls. Code issues can arise for insulation and air sealing materials left exposed that will not pass fire barrier ratings.

#### **Image: Furred Out and Spray Foamed Basement Walls (vapor-permeable polyurethane)**



#### **Related Strategies:**

IDP21, IDP25, EA45

#### **References/Resources:**

Renovating Your Basement - [www.buildingscienceconsulting.com/resources/foundations/renovating\\_your\\_basement.pdf](http://www.buildingscienceconsulting.com/resources/foundations/renovating_your_basement.pdf)

“Upgrading Below Grade”

[www.pathnet.org/sp.asp?id=23716](http://www.pathnet.org/sp.asp?id=23716)

## **Building Envelope**

### **48. Optimize energy performance**

#### **Strategy included in: Home Performance, Major Addition, Gut Rehab, Deep Energy Retrofit**

Energy efficiency is the single most important priority in green building. Any remodeling project, but most importantly those involving a substantial portion of the building envelope, should optimize the overall energy performance of the home. This means that ALL loads— heating/cooling, domestic hot water, appliances, and lighting—should be evaluated; the right combination of energy improvements is going to be very site- and climate-specific. Information on these loads should be gathered prior to the start of design and can involve something as simple as utility bill analysis (see the EPA Energy Star Home Energy Yardstick) or performance testing and energy modeling.

#### **Potential Issues:**

Clients may have their own idea of just what their green remodeling project will emphasize. The green remodeling professional may need to educate his or her client as to the importance of energy efficiency in green building. Utility bill analysis, performance testing, energy modeling results can all strengthen the remodeling professional’s hand in these discussions. Including any energy efficiency tax incentives, rebates, subsidies, special-term financing and homeowner’s insurance premium advantages won’t hurt either.

Keep in mind that managing energy intensively requires that moisture be managed more intensively as well.

ASHRAE is working on guidance for deep energy savings for remodeling projects that should be available late in 2008.

#### **Related Strategies:**

IDP2, IDP3, EA51

#### **References/Resources:**

“Energy-efficient Improvements for Remodeling Projects – Training Modules”

[www.toolbase.org](http://www.toolbase.org)

“City of Boulder Green Points Program – 2008”

[www.bouldercolorado.gov/files/ord\\_7565.pdf](http://www.bouldercolorado.gov/files/ord_7565.pdf)

“Home Energy Yardstick”

[www.energystar.gov/](http://www.energystar.gov/)

### **49. Install attic insulation**

#### **Strategy included in: Home Performance**

While many people think that we generally have or add more insulation to the attic than other locations because “heat rises,” it’s only hot air that rises. The actual increased  $\Delta T$  at the top floor ceiling varies quite a bit based on a number of factors. But the main reason we do attic insulation to a greater degree is: it’s the easiest! The biggest decision is likely to be just how much to add to the attic. Be careful with standard simple payback or even net value payback calculations—neither take into account the unpredictability of energy cost increases. If we are being given professional predictions for oil prices of \$30 per barrel by the year 2030 while prices six months after the prediction are \$80 per barrel, it seems to make sense to tap out every energy improvement option that presents itself.

#### **Potential Issues:**

Given that air-permeable insulations (fiberglass, cellulose) really require six-sided containment for their full benefit, higher density insulation should be considered as a top layer in the attic and/or baffles should be installed at the eaves to protect attic insulation from windwashing by way of soffit venting (see EPA Energy Star Thermal ByPass Checklist). Extra care must be taken to address all thermal bypasses in the attic as insulation is added.

If roof insulation is added on top of the existing roof, the fascia detail can be tricky. See the detail with this strategy.

#### **Image: Spray Foam Insulation at Roof Line for Conditioned Attic**



**Related Strategies:**

IDP25, EA45

**References/Resources:**

“Insulation”

[www1.eere.energy.gov/consumer/tips/insulation.html](http://www1.eere.energy.gov/consumer/tips/insulation.html)

”Recommended Levels of Insulation”

[www.energystar.gov/](http://www.energystar.gov/)

“Home Energy Solutions” (Energy Trust)-

[www.energytrust.org/TA/hes/weatherization/attic.html#at37](http://www.energytrust.org/TA/hes/weatherization/attic.html#at37)**50. Consider a radiant barrier in the attic****Strategy included in: Home Performance, Deep Energy Retrofit, Gut Rehab, Major Addition**

Attic radiant barriers can reduce (primarily) cooling load by reflecting radiant energy or by not reradiating as much energy because of the material’s low emissivity.

**Potential Issues:**

Radiant barriers must face an air space to be effective, and their effectiveness depends on the surface being kept clean and free of dust or other materials.

**Related Strategies:**

EA48

**References/Resources:**

“Radiant Barriers”

[www.eere.energy.gov/consumer/your\\_home/](http://www.eere.energy.gov/consumer/your_home/)

“Radiant Barrier Fact Sheet”

[www.ornl.gov/sci/roofs+walls/radiant/index.html](http://www.ornl.gov/sci/roofs+walls/radiant/index.html)**51. Conduct blower door test (before and after)****Strategy included in: Home Performance, Major Addition, Gut Rehab, Deep Energy Retrofit**

A blower door test is a performance test that uses pressure differences and air flow created by a large calibrated fan to estimate the air tightness of the entire structure; the blower door can be used for room-to-room pressure testing as well. The blower door and associated diagnostic tests can be done in less than 1.5 hours. Before and after testing is important in evaluating energy improvements in existing homes.

**Potential Issues:**

This test does require a block of time during which the testing crew must have considerable access to the home and occupants must stay either in or out of the structure.

**Image: Blower Door Test Set-Up****Related Strategies:**

IDP2

**References/Resources:**

“Blower Door Testing”

[www.pct.edu/wdce/wtc/pdf/Blower-Door-FINAL.pdf](http://www.pct.edu/wdce/wtc/pdf/Blower-Door-FINAL.pdf)**52. Conduct room-to-room pressurization testing****Strategy included in: Basement, Home Performance, Major Addition, Gut Rehab, Deep Energy Retrofit**

Individual rooms can develop significant pressure differences with doors closed. Undercutting at the door’s bottom margin is almost always insufficient to manage room-to-room pressurization—a situation that can lead to interstitial moisture problems in exterior walls. Room-to-room pressure testing is done by turning on the air handler, closing all interior doors to the room, and using a two-station handheld manometer to see if the lack of return-air pathway pressurizes the room compared with the rest of the house or the common areas without doors. The general threshold for room-to-room pressurization is 3 Pascals.

**Potential Issues:**

Solving room-to-room pressurization issues in existing homes typically involves either trimming doors by at least 1.5 inches or cutting offset transfer grilles just above the bedroom doors. The former may not be acceptable to the homeowners and the latter is an invasive operation, particularly if load-bearing walls are encountered.

**Related Strategies:**

IDP4, IEQ170

**References/Resources:**

“Specifications for the Low-Income Weatherization Program Version April 2007”

[www.cted.wa.gov/DesktopDefault.aspx?alias=cted&lang=en&tabID=513&wversion684=Production#Specs](http://www.cted.wa.gov/DesktopDefault.aspx?alias=cted&lang=en&tabID=513&wversion684=Production#Specs)**53. Conduct infrared imaging (before and after)****Strategy included in: Home Performance, Major Addition, Gut Rehab, Deep Energy Retrofit**

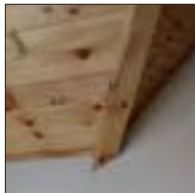
Infrared imaging is a compelling tool for identifying “invisible” conductive heat loss, air leakage, and moisture problems.

**Potential Issues:**

IR imaging requires a temperature difference ( $\Delta T$ ) and associated heat flow, but the cameras have become sensitive enough that even a  $\Delta T$  of 15 °F is enough for meaningful results. IR imaging can be a useful tool when tied to final payment of trade contractors such as insulation and airsealing.

#### Images:

- **Tough-to-Insulate Cathedral Ceiling**
- **After-the-fact Infra Red Image of Cathedral Ceiling**



#### Related Strategies:

IDP2, EA54

#### References/Resources:

“Selecting an Infrared imaging System”  
[www.homeenergy.org/archive/hem.dis.anl.gov/eehem/93/930712.html](http://www.homeenergy.org/archive/hem.dis.anl.gov/eehem/93/930712.html)

### 54. Complete thermal bypass inspection/resolution

#### Strategy included in: Basement, Home Performance, Major Addition, Gut Rehab, Deep Energy Retrofit

Air leakage can represent 24%–40% of the total heat loss in older homes. But just as importantly, air leakage can move significant amounts of moisture with it. Years of testing and field experience indicate that there is a battery of typical large air leakage sites, or thermal bypasses, that can give the most bang for the air tightening buck. EPA Energy Star has compiled the most common air leakage and thermal discontinuities into the Thermal ByPass checklist; it can be used to track, evaluate, and eliminate heat loss and gain associated with air leakage.

#### Potential Issues:

Some of the bypasses will be easier to get to than others. The contractor and the client will need to work out just how aggressive they should be.

#### Images:

- **Thermal Bypass: Duct Chase**
- **Spray Foam to Insulate and Air Seal**



#### Related Strategies:

IDP2, IDP24

#### References/Resources:

“Air seal and insulate with Energy Star”  
[www.energystar.gov/](http://www.energystar.gov/)  
“EPA Energy Star Thermal ByPass Checklist”  
[www.energystar.gov/](http://www.energystar.gov/)

### 55. Airseal/insulate rim joists

#### Strategy included in: Basement, Home Performance, Major Addition, Gut Rehab

In homes with full basement or crawlspace, the first-floor rim or band joist is one of the major places of conductive heat loss and air leakage. Given that this area of the home is going to be covered up as the basement is finished, it is doubly important to insulate and air seal before finishing a basement. Fiberglass or cellulose insulation cannot serve as a continuous air barrier; a combination of rigid insulation and caulking or sealant is required, or a spray polyurethane foam insulation should be used that provides a very complete air seal.

#### Potential Issues:

The quantity of spray foam required is small enough that you may not be able to line up a spray polyurethane foam contractor or get a reasonable price to have a spray foam company foam the rim joist. But this area is large enough to make it unreasonable to foam “by the can.” So-called “froth paks” can fit the bill, however. If spray foam is used for the band joist, note that building codes generally require this material to not be left exposed to living space; it must be covered by a non-combustible material such as gypsum board.

#### Image: Spray Foam Insulation at Rim Joists



#### Related Strategies:

EA47, EA54

#### References/Resources:

“EPA Energy Star Thermal ByPass Checklist”  
[www.energystar.gov/](http://www.energystar.gov/)  
“A Do-It-Yourself Guide to Energy Star Home Sealing”  
[www.energystar.gov/](http://www.energystar.gov/)

### 56. Upgrade existing windows

#### Strategy included in: Kitchen, Home Performance, Gut Rehab, Deep Energy Retrofit

The greatest gain in performance is obtained by sash or whole-window-unit replacement, but when circumstances don't allow this approach, substantial improvement in energy performance and window unit durability can be achieved with exterior, airtight, low-e storm windows. Although storms are not NFRC-certified, research has shown that storm windows significantly improve single-pane window performance and, when installed on the exterior, also shield the existing sashes from bulk water and UV degradation.

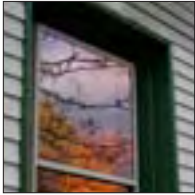


Storm windows, particularly airtight ones, can have substantial impact on noise reduction from exterior sources (traffic, neighbors, etc.).

**Potential Issues:**

Be aware of the potential for continued lead paint exposure from old painted windows, sash, or trim. The low-e coating on most storm windows is an exposed hard coating on the interior surface that can be damaged by aggressive cleaning. Homeowners should be advised to clean the storm's interior only when absolutely necessary and to avoid excessive cleanser and rubbing action.

**Image: Air-tight, Low-e Triple-Track Storm Window**



**Related Strategies:**

IDP4, IEQ193

**References/Resources:**

“Windows”

[www1.eere.energy.gov/consumer/tips/windows.html](http://www1.eere.energy.gov/consumer/tips/windows.html)

“Windows, Doors, and Skylights”

[www.eere.energy.gov/consumer/your\\_home/](http://www.eere.energy.gov/consumer/your_home/)

“Creating Windows of Energy-Saving-Opportunity”

[www.homeenergy.org/archive/hem.dis.anl.gov/eehem/97/970908.html](http://www.homeenergy.org/archive/hem.dis.anl.gov/eehem/97/970908.html)

## 57. Upgrade existing exterior door

**Strategy included in: Kitchen, Home Performance, Living & Working**

Air sealing minor leakage areas, such as windows and doors, do not typically give a big boost to an existing home's air tightness but they can have a disproportionate impact on thermal comfort. Go for the biggest leaks on windows and doors, using qualitative information from “smoke-stick” testing around door and window joints and margins.

**Potential Issues:**

If you have not addressed the big air leaks first, (see EPA Energy Star Thermal ByPass Checklist above) there will be little to gain from buttoning up all the doors and windows

**Related Strategies:**

EA54

**References/Resources:**

“Storm Doors”

[www.eere.energy.gov/consumer/your\\_home/](http://www.eere.energy.gov/consumer/your_home/)

“ECM: Building Envelop: Install Storm Doors”

[www.hud.gov/offices/pih/programs/ph/phecc/strat\\_B4.cfm](http://www.hud.gov/offices/pih/programs/ph/phecc/strat_B4.cfm)

## 58. Weatherstrip doors and windows

**Strategy included in: Home Performance**

Air sealing minor leakage areas, such as windows and doors, do not typically give a big boost to an existing home's air tightness but they can have a disproportionate impact on thermal comfort. Go for the biggest leaks on windows and doors, using qualitative information from “smoke-stick” testing around door and window joints and margins.

**Potential Issues:**

If you have not addressed the big air leaks first, (see EPA Energy Star Thermal ByPass Checklist above) there will be little to gain from buttoning up all the doors and windows.

**Image: Interior Trim Removed to Insulate/Air Seal Sash Pockets after Sash Replacement**



**Related Strategies:**

EA54

**References/Resources:**

“Caulking and Weatherstripping”

[www.eere.energy.gov/consumer/your\\_home/](http://www.eere.energy.gov/consumer/your_home/)

## 59. Replace existing windows

**Strategy included in: Kitchen, Gut Rehab, Deep Energy Retrofit**

Replace existing windows and doors with climate-appropriate high performance products. In general, about one third of a window's performance comes from these three aspects of the window: the glazing, the sash, and the spacer system. The three primary performance properties of windows are U-factor (thermal conductivity or the amount of heat that conducts through a material), solar heat gain coefficient (SHGC—how much of the sun's heat energy is transmitted through the glazing), and visual transmittance (VT—the percentage of visible light transmitted through the glazing). The National Fenestration Research Council (NFRC) has a standardized test procedure to report these properties, and the Efficient Windows Collaborative provides climate-specific guidance on glazing selection. This chart shows the “best” performance climate-specific window properties:

Metric	CC/IRC Climate Region			
	Northern CZ 5-8	North Central CZ 4	South Central CZ 3	Southern CZ 1-2
U-Factor	≤ 0.30	≤ 0.32	≤ 0.32	≤ 0.55
SHGC	Any	≤ 0.40	≤ 0.30	≤ 0.30

Note that these U-factor and SHGC recommendations assume that the same glazing is used on all orientations of a house. If different glazings are used on different orientations, as many green designers recommend, the optimal SHGC may be higher for south-facing windows, particularly in more northern climates. Many green designers also recommend selecting even higher-performance windows with triple glazing and two low-e coatings in northern climates, in which case the U-factor could be as low as 0.20. Visual transmittance (VT) numbers should be as high as possible, regardless of U-factor and SHGC numbers.

#### Potential Issues:

It can be challenging from a manufacturing standpoint to achieve low U-factor, high SHGC, and high VT with a window that still works well for passive solar gain.

Specifying different glazing properties for different orientations is important but challenging.

Not many building professionals or even building code officials follow code requirements for design pressure (DP) ratings for windows, but they are an important indication of the durability and airtightness of windows. Use higher DP ratings of windows to further improve their performance. Also, the more airtight the window, the better the acoustical separation of the inside and the outside of the home.

Bay and bow windows: These are popular replacement windows. But their projection moves the drainage plane, air barrier, and thermal barriers out of the plane of the exterior wall. Care must be taken to properly flash the shed roof of the projecting unit and to air-seal and insulate the head and sill of the unit. The R-value of the window unit “ceiling” and “floor” should be equivalent to that of the wall into which the window unit is installed. This usually means rigid insulation several inches thick and well-fitted caulk and/or spray-foam sealant at all margins.

Roof windows or skylights are a popular component of many remodeling projects. But care should be taken in their sizing, location, and performance properties in terms of unwanted solar gain and glare. The geometry of the installation (roof angle and curb/well design) has a big impact on skylight performance.

#### Related Strategies:

IDP24, EA45, EA48

#### References/Resources:

Efficient Windows Collaborative - [www.efficientwindows.org/](http://www.efficientwindows.org/)

NFRC - [www.nfrc.org/](http://www.nfrc.org/)

“SkyVision free software”

[www.irc.nrc-cnrc.gc.ca/ie/lighting/daylight/skyvision\\_e.html](http://www.irc.nrc-cnrc.gc.ca/ie/lighting/daylight/skyvision_e.html)

## 60. Specify different window glazings for different orientations

### Strategy included in: Major Addition, Gut Rehab, Deep Energy Retrofit,

Because solar radiation (sun angle and intensity) is very different on different orientations, it makes a great deal of sense to “tune” glazings by orientation. On south-facing windows, where wintertime solar heat gain is generally desirable, it makes sense to install windows with high solar heat gain coefficient (SHGC) and low-e. On east and west windows, controlling unwanted solar heat gain is important—because the solar gain is the greatest during the warmer months of the year—so it makes sense to install windows that have lower SHGC values and higher R-values (lower U-values). On north windows, maximizing the R-value is important and SHGC is not a significant concern.

#### Potential Issues:

Without the NFRC label, it is nearly impossible to distinguish identical windows except for their different glazings, so there is risk of mixing up windows intended for particular orientation. To avoid this problem, some designers or builders design slightly different window sizes for the different orientations.

#### Related Strategies:

EA48

#### References/Resources:

Efficient Windows Collaborative - [www.efficientwindows.org/](http://www.efficientwindows.org/)

*Residential Windows*, John Carmody et al.

[www.efficientwindows.org/books.cfm](http://www.efficientwindows.org/books.cfm)

## 61. Provide shading of skylights as needed

### Strategy included in: Bathroom, Working & Living

Skylights and roof windows can cause significant overheating, especially when mounted on south or west roofs. The highest sunlight penetration through glazing occurs when the rays of the sun are normal (perpendicular) to the glazing plane. During the hot summer months, roof-mounted glazing is usually much closer to normal—especially on south-facing and west-facing roofs—than vertical (window) glazing, so solar gain is a significant concern. Some skylights have integral blinds—typically mounted between the panes

of glass—that can be opened and closed to control heat gain. Some skylights are available with electrochromic glazing that allows users to tint the glass with a push of a button (a small amount of electric current tints a coating on the glass and maintains that tint as long as the current remains). Exterior shading systems are also effective, but not widely available in the North American market.

**Potential Issues:**

Skylights with integral blinds or screening are more expensive than standard skylights and electrochromic skylights are very much more expensive.

**Related Strategies:**

EA83

**References/Resources:**

Efficient Windows Collaborative - [www.efficientwindows.org/](http://www.efficientwindows.org/)  
NFRC - [www.nfrc.org/](http://www.nfrc.org/)  
“SkyVision free software”  
[www.irc.nrc-cnrc.gc.ca/ie/lighting/daylight/skyvision\\_e.html](http://www.irc.nrc-cnrc.gc.ca/ie/lighting/daylight/skyvision_e.html)  
[www.sage-ec.com](http://www.sage-ec.com)

## 62. Install awnings or other exterior window shading system

**Strategy included in: Major Addition, Gut Rehab, Deep Energy Retrofit**

In hot, sunny regions, it often makes sense to provide awnings, overhangs, or other shading devices on west-, east-, and south-facing windows. The type and configuration of shading system depends on the location, because much of the overheating potential from west- and east-facing windows comes from the side rather than overhead. A good energy designer should provide input on the shading system and design, including the relationship between glazing choices and shading.

**Potential Issues:**

An improperly designed and implemented overhang or awning may block too much daylight and reduce beneficial passive solar heating.

**Related Strategies:**

IDP1, IDP3

**References/Resources:**

“LBL Shading Strategy”  
[windows.lbl.gov/daylighting/designguide/section5.pdf](http://windows.lbl.gov/daylighting/designguide/section5.pdf)  
“FSEC Window Orientation and Shading”  
[www.fsec.ucf.edu/en/consumer/buildings/homes/windows/](http://www.fsec.ucf.edu/en/consumer/buildings/homes/windows/)  
“Awnings in Residential Buildings: The Impact on Energy Use and Peak Demand”  
[www.awninginfo.org/images/stories/documents/pdf/energystudy22007.pdf](http://www.awninginfo.org/images/stories/documents/pdf/energystudy22007.pdf)

## HVAC

### 63. Use ACCA Manual J, S, and D in mechanical system design

**Strategy included in: Major Addition, Gut Rehab, Deep Energy Retrofit**

Standards developed by the Air Conditioning Contractors of America (ACCA) should be used for calculating energy loads (Manual J), for mechanical system sizing (Manual S), and for duct design (Manual D). Someone involved in the project—the architect, the builder, the HVAC contractor, the HERS rater or energy professional—should conduct this work.

Correct sizing is essential to maximizing HVAC energy efficiency. Significant improvements to the building envelope will reduce load demands dramatically and require less robust HVAC systems. Too frequently, HVAC equipment is oversized using too much energy and creating the need for advanced controls. A properly-sized system will reduce energy demand, provide more comfort, and rely less on operator programming and advanced controls.

Ensure proper sizing and installation by following the Energy Star/ACCA Quality Installation Standards ([www.acca.org/quality/](http://www.acca.org/quality/)).

Work with your designer, builder and contractor to ensure that HVAC equipment is installed leaving enough space for proper airflow, which may exceed local building codes, and be accessible for routine maintenance.

**Potential Issues:**

Some training may be required to effectively use the design tools.

When replacing HVAC equipment, but leaving the ducts in place, use, at the very least, a Manual J to ensure correct sizing.

**Related Strategies:**

IDP3, EA45

**References/Resources:**

“ACCA Quality Installation”  
[www.acca.org/quality/](http://www.acca.org/quality/)  
“HARDI Architect, Builder & Remodeler Good Practice Guide”  
[www.hardinet.org/pdf/GdPractGuide2.pdf](http://www.hardinet.org/pdf/GdPractGuide2.pdf)

### 64. Provide appropriate controls and zoning for HVAC

**Strategy included in: Basement, Major Addition, Gut Rehab, Deep Energy Retrofit**

Controls for HVAC equipment can be just as important—or even more important—than the efficiency of equipment. During the heating season, for example, setting back thermostats by ten degrees for eight hours

each night can reduce total heating energy consumption by about 7%. (Note, however, that the degree of setback varies by heating system type and if the system is sized correctly, deep setbacks may pose comfort problems; best to consult a certified HVAC contractor.) Programmable thermostats often provide both nighttime and daytime setbacks, with the option for different set points on weekends when usage patterns will be different. Similar savings can be achieved with daytime setback of air conditioning systems. (Note, however, that refrigerant-based cooling systems are even more sensitive to setback recovery, particularly for right-sized systems.) Along with conventional programmable thermostats, there are some innovative new products that allow homeowners to conveniently bring the house into setback mode when they leave (see [www.GreenSwitch.tv](http://www.GreenSwitch.tv)).

Separate control of different spaces in a house provides another option for savings. Zoning allows homeowners to keep bedrooms cooler in winter than living rooms and kitchens, or unused rooms to be largely unconditioned. Traditionally, hydronic systems can be more easily separated into zones than forced-air systems, but retro-fit forced-air zoning systems have advanced tremendously and some level of zoning is possible with almost all distribution systems.

#### **Potential Issues:**

Not all HVAC controls are appropriate for all applications. Some of the most advanced European controls for boilers, for example, which regulate boiler temperature according to outside temperature, do not work well with usage that involves significant temperature setback. During swing seasons in the fall and spring, lower boiler temperatures will result in very long recovery times to bring a space up to comfortable conditions.

Note that setback thermostats for heat pumps are very different from those for boilers or furnace-based heating systems.

#### **Related Strategies:**

EA48, EA66

#### **References/Resources:**

*Consumer Guide to Home Energy Savings*, 9th Edition, ACEEE, 2007 - [www.aceee.org](http://www.aceee.org)

*Residential Energy*, John Krigger, Saturn Resource Management, 2004

“Thermostats and Control Systems”

[www.eeregov/consumer/your\\_home/space\\_heating\\_cooling/index.cfm/mytopic=12720](http://www.eeregov/consumer/your_home/space_heating_cooling/index.cfm/mytopic=12720)

## **65. Consider alternatives to conventional refrigerant-cycle air conditioning**

### **Strategy included in: Major Addition, Gut Rehab, Deep Energy Retrofit**

Instead of central or room air conditioners that rely on Rankine-cycle compressors and refrigerants, other options may be available. One is to use a whole-house fan, or attic fan, to move a large volume of air through a house at night (through open windows) when the outside air is cool, then close up the house during the day to keep it cool. In dry climates, evaporative coolers (swamp coolers) can provide very energy-efficient cooling by evaporating water into the occupied space. Direct, indirect, or all-indirect evaporative cooling systems allow evaporative cooling to work while adding less moisture to the indoor air (or none at all in the case of the Coolerado system—see [www.coolerado.com](http://www.coolerado.com)). Another option that uses compression air conditioning is to provide ice storage so that the compressor can operate at night during off-peak hours (see [www.ice-energy.com](http://www.ice-energy.com)).

#### **Potential Issues:**

Non-traditional cooling strategies often require more involvement by homeowners. For example, nighttime whole-house ventilation requires opening windows and knowing to operate this system only when the outside air is cooler than the indoor air. The need for such action should be clearly communicated to homeowners.

#### **Related Strategies:**

EA66, EA76

#### **References/Resources:**

“Evaporative Cooling”

[team.lbl.gov/Design-Guide/DGHtml/evaporativecooling.htm](http://team.lbl.gov/Design-Guide/DGHtml/evaporativecooling.htm)

“Residential-scale ice-storage system for space cooling”

[www.adsabs.harvard.edu/abs/1981tcs..meetQ..14H](http://www.adsabs.harvard.edu/abs/1981tcs..meetQ..14H)

## **66. Select high-efficiency HVAC equipment**

### **Strategy included in: Major Addition, Gut Rehab, Deep Energy Retrofit**

There have been dramatic improvements in the efficiencies of heating and air conditioning equipment in recent years. Top-efficiency gas furnaces and boilers have AFUE ratings of 95% or higher. The best oil-fired equipment exceeds 90% AFUE. Central air conditioning systems are available with SEER performance above 15 (the minimum allowable is now SEER 13), and room air conditioners are available with EER performance above 12 (the minimum ranging from 8.5 to 9.8, depending on size). As described under “Consider alternatives to conventional refrigerant-cycle air conditioning,” there are other cooling options that are much more efficient than the best refrigerant-cycle systems.



Air-conditioning efficiency ratings are only achieved by a properly-matched indoor and outdoor cooling system. The mismatched installation of a 13 SEER-rated air-conditioning system could pull performance down as low as 8.5 SEER. Be sure to use a qualified, licensed HVAC contractor who references the ARI Contractor Guide ([www.aridirectory.org/](http://www.aridirectory.org/)) to ensure properly matched system components.

Consider installing an air-to-air heat exchanger (HRV) for fresh air and moisture control to maximize heating energy.

High-efficiency heat pumps can significantly reduce furnace run times in many climates—lowering natural gas demands and maximizing efficiencies.

#### **Potential Issues:**

The importance of equipment efficiency drops when heating or cooling loads are reduced. If there is a limited budget, rather than spending the money to upgrade the heating and cooling equipment, it often makes more sense to reduce heating and cooling loads by putting money into envelope improvements—or upgrading only the HVAC motor to a variable speed motor.

#### **Related Strategies:**

EA65

#### **References/Resources:**

American Council for an Energy-efficient Economy - [www.aceee.org](http://www.aceee.org)

“HARDI Architect, Builder & Remodeler Good Practice Guide” [www.hardinet.org/pdf/GdPractGuide2.pdf](http://www.hardinet.org/pdf/GdPractGuide2.pdf)

### **67. Install programmable thermostats**

#### **Strategy included in: Bedroom, Basement, Major Addition, Gut Rehab, Deep Energy Retrofit,**

During the heating season, setting back thermostats by ten degrees for eight hours each night can reduce total heating energy consumption by about 7%. (Note, however, that the degree of setback varies by heating system type and if the system is sized correctly, deep setbacks may pose comfort problems; best to consult a certified HVAC contractor.) Programmable thermostats often provide both nighttime and daytime setbacks, with the option for different set points on weekends when usage patterns will be different. Similar savings can be achieved with daytime setback of air conditioning systems. (Note, however, that refrigerant-based cooling systems are even more sensitive to setback recovery, particularly for right-sized systems.) Along with conventional programmable thermostats, there are some innovative new products that allow homeowners to conveniently bring the house into setback mode when they leave (see [www.GreenSwitch.tv](http://www.GreenSwitch.tv)).

#### **Potential Issues:**

Setback thermostats for heat pumps are very different from those for boilers or furnace based heating systems; consult the heat pump manufacturer or contractor about proper operation. With radiant-floor heat distribution, the thermal lag results in long recovery times, so set-back settings should be adjusted accordingly (consult radiant floor designer or installer).

An important element of programmable thermostats is their simplicity, or ease of operation. Programmable thermostats will not be used or not be used properly, if they are complex and non-intuitive.

#### **Related Strategies:**

EA103, EA104, EA105

#### **References/Resources:**

“Programmable Thermostats”

[www.energystar.gov/](http://www.energystar.gov/)

[www1.eere.energy.gov/consumer/tips/thermostats.html](http://www1.eere.energy.gov/consumer/tips/thermostats.html)

### **68. Conduct duct tightness test (before and after) in homes with forced air systems**

#### **Strategy included in: Basement, Home Performance, Deep Energy Retrofit**

A duct blaster test is a performance test that uses pressure differences and air flow created by a calibrated fan to estimate the air tightness of forced-air duct systems. If a home has a duct distribution system, its performance can be a big player in terms of both energy performance, thermal comfort, and indoor air quality. Before and after testing is important in evaluating energy improvements in existing homes.

#### **Potential Issues:**

To conduct this test, the home will be without space conditioning for approximately one half to one hour.

#### **Image: Duct Blaster Test Set-Up**



#### **Related Strategies:**

EA51, EA63

#### **References/Resources:**

“Minneapolis Duct Blaster Operation Manual”

[www.energyconservatory.org/download/dbmanual.pdf](http://www.energyconservatory.org/download/dbmanual.pdf)

“Energy Star/ACCA Quality Installation Standards”

[www.energystar.gov/](http://www.energystar.gov/)

## 69. Properly commission new (or tune existing) HVAC systems

### Strategy included in: Basement, Major Addition, Home Performance, Gut Rehab, Deep Energy Retrofit

Mechanical equipment should be inspected, tested, and tuned up after installation. Both forced-air and hydronic distribution systems must be properly balanced to ensure even distribution of heat, chilled air, or ventilation air. Test the controls to make sure that they are functioning properly. Existing equipment should be tuned up on a regular basis (typically annually) to ensure that it is operating at top efficiency. At least annually, but sometimes as often as every three months, air filters for furnaces, air conditioners, heat pumps, and ventilation systems should be inspected or replaced.

Be sure to have air-conditioning systems checked thoroughly for refrigerant leaks that will emit refrigerant gasses into the atmosphere. Should your system require extensive service or replacement, insist that proper EPA regulations are met and all refrigerants are properly recovered and disposed. Refer to ACCA Quality Maintenance Guidelines (currently in final stages of development).

#### Potential Issues:

Improperly balanced forced-air distribution systems can result in leakage through the ducts or can depressurize the house, drawing in radon and other hazardous soil gases.

#### Related Strategies:

EA48, EA103

#### References/Resources:

“Energy Star/ACCA Quality Installation Standards”  
[www.energystar.gov/](http://www.energystar.gov/)

“HARDI Architect, Builder & Remodeler Good Practice Guide”  
[www.hardinet.org/pdf/GdPractGuide2.pdf](http://www.hardinet.org/pdf/GdPractGuide2.pdf)

## 70. Properly seal and insulate HVAC distribution system

### Strategy included in: Home Performance, Gut Rehab, Deep Energy Retrofit

With forced-air distribution for heating and cooling systems it is not uncommon for duct losses to result in a 30% reduction in overall efficiency. With hydronic heating, uninsulated pipes running through unconditioned or partially conditioned spaces can lower efficiency and can pose failure problems. Both ducting and hydronic piping should be kept within the insulated envelope and kept out of exterior walls whenever possible. All ducting should be properly sealed with mastic designed for duct sealing, and any ducts that extend through unconditioned or partially conditioned space should be insulated to, or preferably beyond, code

minimums. Test the airtightness of ducting after sealing and insulating using a Duct Blaster or comparable duct testing equipment. Hydronic piping that extends through unconditioned or partially conditioned space should be fitted with pipe insulation providing a minimum of R-3.

#### Potential Issues:

Unless you have a high performance HVAC contractor already on board, it can be hard to keep the focus on HVAC strategies such as this one. Consider bringing an energy professional, such as a HERS rater, on board for systems integration of HVAC strategies.

Fiberglass ductboard and poorly sealed metal ducts insulated with fiberglass can release fibers into the household air. Avoid fiberglass duct insulation unless that insulation is coated to prevent fiber shedding.

#### Related Strategies:

EA48

#### References/Resources:

“HARDI Architect, Builder & Remodeler Good Practice Guide”  
[www.hardinet.org/pdf/GdPractGuide2.pdf](http://www.hardinet.org/pdf/GdPractGuide2.pdf)

## 71. Make sure ducting is clean

### Strategy included in: All Projects

Ensuring that air-distribution ducts (for heating, cooling, and ventilation systems) are clean is an important priority in maintaining a healthy indoor environment. This is particularly important following construction or remodeling work. Procedures for cleaning ducts depend on the type of duct; the easiest to clean are sheetmetal ducts that are insulated on the outside. At the time of cleaning ducts, they should also be pressure-tested using a Duct Blaster system.

#### Potential Issues:

The first step should be to cover registers and any other duct openings during renovation; this can be done using plastic and duct tape, or with a specialized product, such as Speedi-Boot ([www.speediboot.com](http://www.speediboot.com)).

Ducts should only be cleaned by trained professionals; improper cleaning can release particulates and other contaminants into the household air, causing rather than solving problems.

#### Image: Duct Protection During Renovation



#### Related Strategies:

IEQ158

## References/Resources:

“Should You Have the Air Ducts in Your Home Cleaned?”  
[www.epa.gov/iaq/pubs/airduct.html](http://www.epa.gov/iaq/pubs/airduct.html)  
National Air Duct Cleaners Association - [www.nadca.com/](http://www.nadca.com/)  
[www.energyconservatory.com/products/products2.htm](http://www.energyconservatory.com/products/products2.htm)

## 72. Provide air-lock dryer vent

### Strategy included in: Bathroom

The vent used to exhaust hot moist air from drying clothes can be a major source of air infiltration when the dryer is not operating. Install a dryer vent cap that protects against air infiltration.

### Potential Issues:

The dryer vent cap should not unduly restrict exhaust air flow or lint will collect and drying performance will drop (and energy use increase).

### Related Strategies:

EA106

## References/Resources:

“Heartland Dryer Vent Closure”  
[www.energyfederation.org/consumer/default.php/cPath/86\\_742\\_110](http://www.energyfederation.org/consumer/default.php/cPath/86_742_110)

*Consumer Guide to Home Energy Savings*, 9th Edition, ACEEE, 2007- [www.aceee.org](http://www.aceee.org)

## 73. Minimize dryer duct length and number of turns

### Strategy included in: Bathroom

It is the duct length and number of turns that determine resistance to air flow. Use only smooth, rigid metal ducting for dryer exhaust and keep length of the run and number of turns to a minimum. For the addition of a booster fan, follow the dryer manufacturer instructions for length and number of turns that exceed the dryer’s capacity to efficiently exhaust.

### Potential Issues:

There are very few structures or climates for which clothes dryer exhaust should be vented inside conditioned space. The energy saved during the winter is offset by the increased moisture risk, particularly in rooms or parts of rooms where the exhaust originates. As a rule, do not vent clothes dryer exhaust internally.

### Related Strategies:

IEQ158

## References/Resources:

“In-line Fans”  
[www.toolbase.org](http://www.toolbase.org)  
“Energy Note: Buying and Using Clothes Washers and Dryers”  
[www.oregon.gov/ENERGY/CONS/RES/docs/apntwas.pdf](http://www.oregon.gov/ENERGY/CONS/RES/docs/apntwas.pdf)

## 74. Discontinue unconditioned basement or crawl-space ventilation

### Strategy included in: Basement, Gut Rehab, Deep Energy Retrofit

In more humid climates, including most of the U.S. east of the Mississippi River, summertime ventilation of basements and unconditioned crawl spaces has been found to introduce more moisture than it removes. Therefore, in most situations, it is advisable to keep windows and ventilation ports to these spaces closed.

### Potential Issues:

There will be situations in which this general recommendation to seal unconditioned basements and crawl spaces during the summer months does not apply. Consult an engineer or other building professional with experience in building science if unsure. Some building codes still require basement and crawl space ventilation, so it may be a challenge to convince local building officials that such requirements are based on bad science; ask for exemptions to these requirements, citing the extensive field research on unvented crawlspaces done by organizations such as Building Science Corporation or Advanced Energy Corporation.

### Related Strategies:

IDP124

## References/Resources:

“Conditioned Crawlspace Construction, Performance and Codes”  
[www.buildingscienceconsulting.com/resources/foundations/](http://www.buildingscienceconsulting.com/resources/foundations/)  
Advanced Energy Corporation Knowledge Library -  
[www.advancedenergy.org/buildings/knowledge\\_library/crawl\\_spaces/](http://www.advancedenergy.org/buildings/knowledge_library/crawl_spaces/)

## 75. Avoid ozone-depleting refrigerants

### Strategy included in: Deep Energy Retrofit, Gut Rehab, Basement

CFCs or chlorofluorocarbons were phased out in the 1990s after they were clearly implicated in depletion of the Earth’s stratospheric ozone layer, which protects us from high-energy ultraviolet radiation. CFCs were mostly replaced with HCFCs, which are less damaging to ozone but still a problem. Now, most of the HCFCs are being eliminated, according to international treaty, and replaced with ozone-safe HFCs, hydrocarbons such as pentane, and other compounds. Refrigerants used in air conditioning equipment are still largely dependent on HCFC refrigerants, including R-22, though some products are now coming onto the market that use non-ozone-depleting HFC refrigerants. In selecting air conditioning equipment, look for products using ozone-safe refrigerants—or no refrigerants at all.

## Residential Refrigerants that are Acceptable Based on ODP and GWP Ratings

Refrigerant	Combined LCGWP+ LCODP Score	System Refrigerant Charge	Size Equip	Leakage Rate	Life
R410A	152	2 Ton	3.7 Lb/Ton	1.5%	15 Years
R410A	151	3 Ton	3.0 Lb/Ton	2.0%	15 Years
R410A	151	4 Ton	3.0 Lb/Ton	2.0%	15 Years
R410A	121	5 Ton	3.0 Lb/Ton	2.0%	15 Years

Source: U.S. Green Building Council

### Potential Issues:

Central air conditioning systems are increasingly available with ozone-safe refrigerants but window or room air conditioners are several years behind in replacing HCFCs, so finding alternative products will be more difficult.

Non-HCFC refrigerants may lower the overall energy efficiency of air conditioning equipment to some extent. This lower efficiency can be compensated for by using better heat exchangers and ECM motors, but those features will raise costs. Some ozone-safe refrigerants are also fairly potent greenhouse gases (compounds that contribute to global warming by trapping heat in the atmosphere). The U.S. Green Building Council recommends considering both the ozone-depletion potential (ODP) and the global warming potential (GWP) of refrigerants when selecting cooling equipment.

### Related Strategies:

EA65, EA76

### References/Resources:

“What You Should Know about Refrigerants When Purchasing or Repairing a Residential A/C System or Heat Pump”  
[www.epa.gov/ozone/title6/phaseout/22phaseout.html](http://www.epa.gov/ozone/title6/phaseout/22phaseout.html)

## 76. Install ceiling fan

### Strategy included in: Bedroom, Living & Working, Major Addition, Finished Basement

Ceiling fans provide an inexpensive way to reduce air conditioning needs in homes—by helping people feel comfortable at higher air temperatures. Air flow from a ceiling fan increases evaporation and allows homeowners to be comfortable at air temperatures of 82°F or sometimes even higher. In other words, ceiling fans raise the temperature “comfort window” in a room.

### Potential Issues:

To be able to install a ceiling fan, there must be adequate ceiling height; check local building code requirements. Advise homeowners to turn off ceiling fans when they leave a room because the fan does not actually cool a room (it actually raises the air temperature slightly,

because of waste heat from the motor), but rather helps people maintain comfort at higher air temperatures. Also, advise homeowners that energy savings from the use of ceiling fans will only be achieved if the thermostat is turned up—so that the air conditioner comes on less.

### Related Strategies:

EA103, EA104

### References/Resources:

“Ceiling Fans”  
[www.energystar.gov/](http://www.energystar.gov/)

## Plumbing

### 77. Reconfigure plumbing to distribute domestic hot water efficiently

#### Strategy included in: Kitchen, Basement, Deep Energy Retrofit

Optimizing hot water plumbing runs means: pipe diameter no larger than is required for the flow, runs no longer than are needed, the minimum number of hard angle bends, and no plumbing runs in the exterior building envelope. “Home-Run” plumbing systems, in which individual runs of PEX tubing are made to each fixture from a central manifold with the tubing diameter optimized for the flow-rate of the fixture, are one approach for optimizing hot water distribution. When there is a very long distance from the water heater to the kitchen sink, wasted water and long waits for hot water can be reduced with an on-demand recirculating system that uses a small, user-controlled pump to bring hot water to the sink quickly and returns water in the pipe back to the water heater.

### Potential Issues:

The functionality of the kitchen space may not lend itself to optimal plumbing distribution for energy and water efficiency.



## Image: PEX Plumbing for Efficient Distribution of Hot Water



### Related Strategies:

IDP3, EA48

### References/Resources:

“Hot Water Delivery – Systems and Construction Practices”  
[www.awwa.org/waterwiser/references/pdfs/RES\\_HW\\_Klein\\_G\\_Hot\\_Water\\_Delivery\\_Systems\\_and\\_Constructi.pdf](http://www.awwa.org/waterwiser/references/pdfs/RES_HW_Klein_G_Hot_Water_Delivery_Systems_and_Constructi.pdf)

“Tech Set 1: Resource Efficient Plumbing”  
[www.toolbase.org](http://www.toolbase.org)

## 78. Install on-demand hot water recirculation system

### Strategy included in: Kitchen, Bathroom

Significant energy and water can be wasted running cooled hot water down the drain while waiting for the true hot water to make it from the water heater to the point of use. On-demand recirculation systems have been shown, in retrofit, to result in a change in user behavior and reduced resource use. The cold water line is used as a return so that cooled hot water is moved back to the water heater by a high speed pump that only runs when activated and just long enough to get the up-to-temperature hot water to the point of draw.

### Potential Issues:

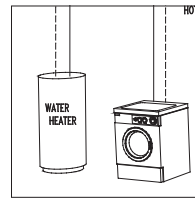
The recirculation pump must be properly sized to the pressure drop of the runs and the user must adjust to the activation system. And if the cold water line is used as the return, some “cold” water can be wasted when a user draws cold water to drink that has been warmed when acting as the return line.

NOTE: The term “on-demand” is also often used to refer to tankless water heating systems. With hot water recirculation systems, the term “on-demand” is used to indicate that the hot water recirculation pump only runs when a user hits the activation button and hot water is demanded.

## Image: On-Demand Recirculation Pump for Hot Water



## Detail: Typical On-Demand Recirculation System



### Related Strategies:

IDP3, EA77

### References/Resources:

“Benefits of Demand-Controlled Pumping”  
[www.cuwcc.org/res\\_hot\\_water/Home\\_Energy\\_Magazine\\_Sept-Oct-2006.pdf](http://www.cuwcc.org/res_hot_water/Home_Energy_Magazine_Sept-Oct-2006.pdf)

## 79. Choose a high-efficiency water heater

### Strategy included in: Basement, Home Performance, Gut Rehab, Deep Energy Retrofit

A water heater can be one of the two or three largest energy users in a home. Whether electric or gas-fired, whether storage or tankless, it is important to select a high-efficiency model. The energy performance of storage-type water heaters is determined by the amount of insulation around the tank, the efficiency of the heat exchanger, and (with gas water heaters) the burner configuration and efficiency. With gas-fired tankless (demand) water heaters, models with electronic ignition are significantly more efficient than models with pilot lights; some of these models include very high-efficiency heat exchangers and condensing technology. Electric-demand water heaters are not recommended for whole-house applications, because of the very large power demand (typically 40 to 60 amps at 240 volts).

Finally, probably the most efficient way to heat hot water is by using the sun. See consider solar water heating strategy.

### Potential Issues:

With gas-fired water heaters, choose sealed-combustion models to prevent risk of spilling combustion gases into the house.

Tankless (demand) water heaters have been gaining a lot of attention recently, and they can make a lot of sense in the right situation. Because demand water heaters do not store hot water, there is no *stand-by* heat loss, which results in much of the efficiency loss with storage-type water heaters. For whole-house applications, only gas-fired models are viable, because electric models require too much power demand (typically 40 to 60 amps at 240 volts). Whether a demand water heater makes sense for a family depends in part on their hot water usage patterns; if family members turn on the hot-water tap frequently for short periods of time (a quick hand-washing dozens of time per day, for example), a demand water heater may not make sense, because every time the hot-water

tap is turned on the demand water heater fires up. If that hot water draw is only for a few seconds, the gas burner will never reach full efficiency by the time it shuts off, and the frequent cycling on and off will waste energy. Combining domestic water heating and space heating in a tankless water heater in colder climates may result in an overall lower level of energy efficiency compared to the most efficient alternatives (condensing efficiency gas-fired furnaces and boilers).

If domestic water heating is combined with space heating, be sure that a switch to a tankless water heating system does not result in an overall drop in system efficiency.

**Image: One Approach to Efficient Water Heater: Gas Tankless**



**Related Strategies:**  
EA77, EA101

**References/Resources:**

- “Selecting a New Water Heater”  
[www.eere.energy.gov/consumer/your\\_home/](http://www.eere.energy.gov/consumer/your_home/)
- “Consumer Guide to Home Energy Savings: Water Heating”  
[www.aceee.org/consumerguide/waterheating.htm](http://www.aceee.org/consumerguide/waterheating.htm)

**80. Insulate water heater**

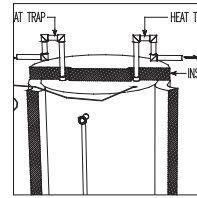
**Strategy included in: Basement, Home Performance, Deep Energy Retrofit**

Insulating storage-type water heaters reduces standby heat loss, so improves overall energy efficiency. If the water inside a tank water heater is 130°F, and the air temperature of the space in which it sits is 70°F, there is a larger temperature differential driving heat loss from the tank than there is between the inside and outside temperature of the house for all but the coldest of winter nights! Water heater blankets are available from weatherization supply companies and from some utility companies. Most are fiberglass with vinyl backing. Convective flow of hot water out of the water heater can be stopped with a “heat trap” valve or a loop in the pipe above the water heater. Be sure to also insulate hot water pipes leading from the water heater (see “Insulate Hot Water Pipes”).

**Potential Issues:**

With gas-fired natural draft water heaters, air flow beneath the water heater must not be blocked—because that air flow is needed for combustion. Follow manufacturer’s instructions for insulation.

**Detail: Improving Efficiency of Existing Water Heater**



**Related Strategies:**  
EA81

**References/Resources:**

- Consumer Guide to Home Energy Savings*, 9th Edition, ACEEE, 2007- [www.aceee.org](http://www.aceee.org)
- Residential Energy*, John Krigger, Saturn Resource Management, 2004
- “Insulate Your Water Heater Tank for Energy Savings”  
[www.eere.energy.gov/consumer/your\\_home/](http://www.eere.energy.gov/consumer/your_home/)

**81. Insulate hot water pipes**

**Strategy included in: Basement, Home Performance, Gut Rehab, Deep Energy Retrofit**

To slow down the cool-off of hot water in the hot-water piping, all hot water pipes should be insulated. This will increase the likelihood that water in the pipes will be suitably warm when turned on, thus reducing water waste (waiting for hot water) and limiting the time of operation of a water heater. If all hot-water pipes cannot be insulated easily, the first six to eight feet of pipe from the water heater are most important; insulate elbows and fittings in addition to straight runs.

In addition to insulating hot water pipes, it also makes sense to insulate cold-water pipes in an area with high summertime humidity—to prevent condensation of moisture on the pipes (which can result in mold growth and decay of cellulosic materials).

**Potential Issues:**

Select a durable pipe insulation material that can withstand the highest temperatures that will be experienced. Some low-cost pipe insulation does not hold up well in the long term. Pipe insulation must be tight-fitting to be effective, and while elbows and angles are harder to insulate, their greater surface area makes them that much more important to properly insulate. Hot water pipes in existing slabs can (of course) not be insulated but in some types of homes and climates, replumbing around these pipes should be considered.

**Related Strategies:**  
EA80

**References/Resources:**

- Consumer Guide to Home Energy Savings*, 9th Edition, ACEEE, 2007- [www.aceee.org](http://www.aceee.org)
- Residential Energy*, John Krigger, Saturn Resource Management, 2004

## 82. Set water heater temperature no higher than necessary

### Strategy included in: Kitchen, Bathroom, Basement

Setting the water heater's thermostat to 120°F can improve safety and conserve energy. Even though 120°F is high enough for most households, and water temperatures above 125°F can cause severe burns, the manufacturer setting may be as high as 140°F. According to EERE, each 10°F reduction in water temperature saves between 3%–5% in energy costs for water heating, and also slows corrosion in the water heater and pipes, helping the water heater to continue to operate efficiently.

### Potential Issues:

A dishwasher without a booster heater may require water temperatures between 130°F to 140°F.

### Related Strategies:

EA103, EA104, EA105

### References/Resources:

"Lower Water Heating Temperature for Energy Savings"  
[www.eere.energy.gov/consumer/your\\_home/](http://www.eere.energy.gov/consumer/your_home/)

## Lighting

## 83. Provide daylighting

### Strategy included in: Kitchen, Major Addition, Deep Energy Retrofit

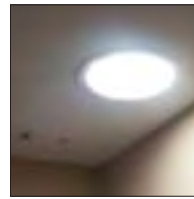
During the daytime, it makes sense to rely on natural lighting. If this daylighting can satisfy ambient lighting requirements, only task lighting will be needed during daytime hours, and electric ambient lighting will only be needed at night or during very dark days.

With new additions and significant house renovations (gut-rehab and whole-house deep energy retrofits), it is especially important to consider the potential for daylighting. Windows, skylights, and tubular skylights can be used to bring natural light into a space during the daytime. Select glazing systems carefully to meet or exceed the energy performance of the rest of the house or addition. With large glazing areas for daylighting, select glazing options that will minimize the increased cooling loads. Light-colored wall and ceiling interiors can help to distribute daylight more deeply into a house.

### Potential Issues:

Poorly implemented daylighting can lead to overheating of a space or an increase in air conditioning loads. South-facing and low-slope roof windows are particularly problematic because the angle permits a high percentage of the sunlight to be transmitted. Careful placement of skylights and glazing selection can minimize this problem. See glazing strategies.

## Image: Solar Tube for Daylighting



### Related Strategies:

IDP3, EA60

### References/Resources:

"Understanding High Performance Lighting: Room-by-Room Designs"  
[www.ibacos.com/hpl5.html](http://www.ibacos.com/hpl5.html)

## 84. Provide appropriate mix of color correct ambient and task lighting

### Strategy included in: Kitchen, Bathroom, Deep Energy Retrofit

Lighting design is not an element of all residential remodeling projects, but it should be. Distinguishing between ambient and task lighting needs is a critical part of effective and energy-efficient lighting design. Ambient, or area, lighting should be provided with daylight during the daytime if at all possible, and fluorescent light for overcast days and night. Indirect fluorescent lighting is quite effective. Task lighting delivers light more precisely where it is needed and can be provided more efficiently with recessed compact fluorescent lamps (CFLs) or LED light fixtures.

### Potential Issues:

While very attractive from an energy-efficiency standpoint, fluorescent lamps contain the toxic metal mercury, which can escape into the environment after disposal, particularly if municipal solid waste is incinerated. Burned-out fluorescent lamps should always be disposed of properly, through facilities that capture the mercury and recycle the components.

With recessed downlights that are installed in an insulated ceiling, use insulation-contact fixtures (IC-rated) that can be properly sealed to prevent air leakage and moisture migration into the attic space.

### Related Strategies:

EA103, EA104

### References/Resources:

"Understanding High Performance Lighting: Room-by-Room Designs"  
[www.ibacos.com/hpl5.html](http://www.ibacos.com/hpl5.html)

## 85. Install energy-efficient electric lighting

### Strategy included in: Kitchen, Bathroom, Home Performance, Deep Energy Retrofit

The new federal energy bill bans incandescent light bulbs by the year 2012. Fluorescent lighting has come a long way in the last several decades, with high-quality lamps offering excellent color rendering, color temperatures that match incandescent lighting, and silent, flicker-free operation. Attractive fixtures are available in many designs (sconce, recessed, surface-mount, indirect cove) for straight-tube and compact fluorescent lamps that work well with most kitchen designs. Energy Star-rated lighting fixtures and lamps ensure good performance in various areas, including color rendering, harmonic distortion, start-up time, long life, and energy-efficiency. While still relatively new, LED lighting is quickly emerging as a viable alternative to incandescent and, in certain applications, fluorescent lighting. LED lighting today is most practical for task and under-counter lighting, though as efficacy improves, LED ambient lighting will become increasingly practical.

#### Potential Issues:

Natural daylighting can be used to reduce the amount of electric lighting that is required.

Install low-mercury fluorescent lamps. Not all fluorescent lamps are created equal in terms of mercury content.

Not all compact fluorescent bulbs are dimmable—take care in specifying and installing.

There is a lot happening in terms of emerging technologies and commercialization of new lighting products. Green remodelers and interior designers will have to stay current with these changes as they are rapidly developing.

#### Related Strategies:

EA83

#### References/Resources:

“Light Bulbs and Fixtures”  
[www.energystar.gov/](http://www.energystar.gov/)

“The Low-down on Mercury in Fluorescent Lamps”  
[www.informinc.org/fact\\_P3fluorescentlamps.php](http://www.informinc.org/fact_P3fluorescentlamps.php)

“Dimmable Compact Fluorescent Lamps Fact Sheet”  
[www.pge.com/includes/docs/pdfs/res/rebates/lighting/dimmercflflyer.pdf](http://www.pge.com/includes/docs/pdfs/res/rebates/lighting/dimmercflflyer.pdf)

## 86. Avoid recessed lights in insulated ceilings or use insulation-contact fixtures

### Strategy included in: Kitchen, Bedroom, Major Addition

Recessed light fixtures installed in insulated ceilings are a very common source of heat loss through air leakage. When possible, use surface-mounted ceiling fixtures or track lighting to avoid penetrating the insulated ceiling

plane. When recessed cans cannot be avoided, specify “insulation-contact” fixtures that seal fairly tightly and allow insulation to be packed against them. To improve energy performance, select fixtures designed for compact fluorescent lamps (CFLs) or LED lighting. The most energy-efficient recessed lights available today are LED lights.

#### Potential Issues:

Insulation-contact recessed light fixtures are more expensive than standard recessed cans. Cost is also higher for CFL fixtures than for incandescent, and higher still for LED fixtures.

#### Related Strategies:

EA54, EA85

#### References/Resources:

Builders Guide to Home Lighting -  
[www.lrc.rpi.edu/programs/lightingTransformation/residentialLighting/buildersguide/introduction.asp](http://www.lrc.rpi.edu/programs/lightingTransformation/residentialLighting/buildersguide/introduction.asp)

*The Lighting Pattern Book for Homes*, Russell Leslie and Kathryn Conway, Lighting Research Center, Rensselaer Polytechnic Institute, 1996 (2007 online)

## 87. Provide adaptable lighting for multi-use spaces

### Strategy included in: Living & Working

In spaces that have varied uses, such as a living room that also serves as a home office, a variety of light sources may be required to meet changing lighting needs throughout the course of the day and evening. One approach is to install a variety of light sources, such as recessed can lights for directional light, wall sconces and cove lighting for ambient light, and task lighting to illuminate an office work desk. Daylighting can also play a role during daytime uses of the space. Another option is to have homeowners rely on moveable lamps, by providing plenty of wall receptacles, some of which can be switched to aid in controllability.

#### Potential Issues:

None

#### Related Strategies:

EA83, EA84

#### References/Resources:

Lighting Research Center at RPI - [www.lrc.rpi.edu/](http://www.lrc.rpi.edu/)

## 88. Select outdoor lighting to minimize light pollution

### Strategy included in: Outdoor Living

Light escaping from our buildings and outdoor spaces around them has brightened the night sky so much that stars are scarcely visible in many parts of the country. Along with the aesthetic concerns and impact on



astronomy, light pollution can affect health by keeping people up at night, and it can even affect wildlife and plants. In coastal areas, sea turtles that come ashore to lay eggs are confused by light pollution and sometimes return not to the sea but toward the lights. Rare moths swarm to outdoor lights and die rather than finding mates. And the flowering patterns of some plants are altered by artificial outdoor lighting. All outdoor lighting should be provided with full-cutoff fixtures (which prevent direct-beam light from exiting the fixture at an angle above the horizontal), and it is possible to go even further with controlling light pollution. The International Dark Sky Association has a certification program for outdoor light fixtures that will minimize light pollution. Motion-sensing controls can turn outdoor lights on only when that light is actually needed.

**Potential Issues:**

While safety is often raised as a concern and justification for high outdoor light levels, studies show that good nighttime visibility is about a lot more than lumen levels; in fact, too much light can reduce visibility.

**Related Strategies:**

IDP3, IDP6

**References/Resources:**

International Dark Sky Association - [www.darksky.org](http://www.darksky.org)

## 89. Provide appropriate outdoor lighting controls as needed

**Strategy included in: Outdoor Living**

Lighting outdoors is often provided primarily for security, or to provide illumination when entering or leaving a house or taking out the trash. For these applications, effective lighting controls that utilize motion sensors are often appropriate. The lights turn on when motion is sensed. Outdoor lighting that is controlled by motion sensors should use lamps that come on instantly, operate at cold temperatures (especially in cold climates), and reach full brightness almost instantly; LED lighting and cold-cathode fluorescent lamps are the best energy-saving options for such lighting. Incandescent lamps are more satisfactory than standard CFLs in most motion-sensor-controlled outdoor lighting applications.

**Potential Issues:**

Some energy-saving lighting, including compact fluorescent lamps (CFLs) take a while to come up to full brightness, especially when cold, so they may not work well for motion-sensor-controlled outdoor lighting.

**Related Strategies:**

EA88

**References/Resources:**

Lighting Research Center Outdoor Lighting Handbook - [www.lrc.rpi.edu/researchAreas/outdoor.asp](http://www.lrc.rpi.edu/researchAreas/outdoor.asp)

## 90. Provide appropriate indoor lighting controls as needed

**Strategy included in: Major Addition, Gut Rehab, Deep Energy Retrofit**

Indoor lighting controls for the home include dimmers, timers, and motion detectors. A whole house lighting control system is the most sophisticated form of indoor lighting control, consisting of zone controllers, a programmable central controller, dimming processors, remote controllers, and tie-ins to the internet, phone system or security system.

**Potential Issues:**

Care must be taken in mixing controlling technology and some types of compact fluorescent lamps and bulbs.

**Related Strategies:**

EA85

**References/Resources:**

“Builder’s Guide to Home Lighting: Controls” [www.lrc.rpi.edu/searchpublications.asp](http://www.lrc.rpi.edu/searchpublications.asp)

“Introduction to Lighting Automation for the Home” [www.aboutlightingcontrols.org/education/papers/homeautomation.shtml](http://www.aboutlightingcontrols.org/education/papers/homeautomation.shtml)

## Equipment

### 91. Properly maintain equipment

**Strategy included in: Kitchen**

Instruct homeowners on proper cleaning and maintenance needs of appliances and equipment:

Refrigerators should be maintained by periodically vacuuming the coils—at least annually, or more frequently. Removing dust from the heat-exchange coils can significantly improve energy performance. With older refrigerators, it is usually necessary to pull the refrigerator out into the room to clean the coils in the back. Most newer refrigerators have more accessible coils. Non-frost-free refrigerators and freezers have to be periodically defrosted to maintain efficient operation. Ovens should be cleaned of accumulated spilled food to ensure safe, efficient operation.

With dishwashers, the food scrap basket—if there is one—should be emptied regularly.

**Potential Issues:**

None

**Related Strategies:**

EA103, EA104, EA105

## References/Resources

*Consumer Guide to Home Energy Savings*, 9th Edition, ACEEE, 2007  
www.aceee.org

“HARDI Architect, Builder & Remodeler Good Practice Guide”  
www.hardinet.org/pdf/GdPractGuide2.pdf

## 92. Select a high-efficiency, H-axis clothes washer

### Strategy included in: Bathroom

The efficiency of clothes washers has improved dramatically in recent years as horizontal-access (H-axis, front-loading) washers have become more common. H-axis washers use about half as much water (with the most efficient using only a third) and conventional, vertical-axis, or top-loading washers because the drum does not have to be filled to ensure that clothes are adequately wetted in the wash cycle—in an H-axis washer the clothes are dipped into and out of water in the bottom of the drum. H-axis washers also typically spin a lot more rapidly than V-axis washers, so they extract a lot more water and the clothes require less drying energy. At a minimum, look for an Energy Star-labeled clothes washer; the current Energy Star standard requires a Modified Energy Factor (MEF) of 1.72 and a maximum Water Factor (WF) of 8.0. The Consortium for Energy Efficiency lists three different tiers for clothes washers. The maximum MEFs and minimum WFs for these tiers are as follows: Tier 1 – MEF 1.8 and WF 7.5; Tier 2 – MEF 2.0, WF 6.0; Tier 3 – MEF 2.2, WF 4.5. Select the highest tier possible to minimize water and energy use. A list of Tier 1, 2, and 3 clothes washers is available from The Consortium for Energy Efficiency.

### Potential Issues:

Horizontal-axis clothes washers are typically more expensive than vertical-axis, top-loading washers. And H-axis clothes washers vary widely in their acoustical performance; it's worth checking *Consumer Reports* on this and other performance issues.

### Image: High Efficiency H-axis Clothes Washer



### Related Strategies:

IDP4, EA106, MR124, MR125

### References/Resources:

Consortium for Energy Efficiency - www.cee1.org  
Energy Star - www.energystar.gov/

## 93. Install an energy-efficient refrigerator

### Strategy included in: Kitchen

Select refrigerators that meet or exceed Energy Star standards. In general, bottom-freezer refrigerators are the most efficient, followed by top-freezer models; side-by-side models are the least efficient. When choosing refrigerators, in addition to looking for Energy Star labels, compare the estimated annual kWh consumption and percent-savings ratings on the yellow EnergyGuide labels. Features such as through-the-door ice makers and water dispensers typically lower the energy performance, so carefully evaluate whether such features are needed.

### Potential Issues:

Be aware that the energy ratings for refrigerators, including Energy Star standards, are based on the size and configuration. A smaller non-Energy Star refrigerator may use less energy than a larger, side-by-side model. Don't get a larger refrigerator than is needed. If continuing to use an older refrigerator, ensure sufficient air flow around condenser coils; new refrigerators are designed to ensure adequate air circulation. Follow manufacturer's instructions for installation.

### Related Strategies:

IDP3

### References/Resources:

“Refrigerators”  
www.cee1.org/resid/seha/refrig/refrig-main.php3

## 94. Choose an energy-efficient dishwasher

### Strategy included in: Kitchen

Most of the energy used by dishwashers is energy used to heat water. Therefore, water-conserving dishwashers are the most energy-efficient. Dishwashers vary considerably in water and energy use.

Dishwashers that rely on condensing technology for drying should introduce less moisture into a kitchen, thus helping to avoid potential moisture problems and reducing air conditioning loads. Also, dishwashers that heat water directly, rather than by way of an open element, may be among the most efficient.

### Potential Issues:

Modern dishwashers have booster heaters that heat the incoming hot water to 140°F or higher, which is considered necessary for optimal washing performance. Be aware that these booster heaters use considerable electricity, which may cause problems with net-zero-energy homes or homes that are off-the-grid and powered by solar electricity.

To minimize use of the electric booster heater in a dishwasher, it MAY make sense to keep the water heater temperature higher than generally recommended (i.e., 140° rather than 120°F).

**Related Strategies:**

IDP3

**References/Resources:**

“Dishwashers”

[www.energystar.gov/](http://www.energystar.gov/)[www.cee1.org/resid/seha/dishw/dishw-main.php3](http://www.cee1.org/resid/seha/dishw/dishw-main.php3)

## 95. Install energy-efficient cooking appliances

**Strategy included in: Kitchen**

Convection ovens are more energy-efficient than standard models because the cook temperature can be reduced or the cook time shortened. The most efficient cooktops are induction models that transfer electromagnetic energy directly to ferrous metal cooking pans, but most induction cooktops are quite expensive. Gas ovens are less energy-efficient than electric ovens because much greater airflow through the oven is required. Gas ovens also use considerable electricity (300 to 500 watts) whenever the oven is operating as a safety feature. Microwave ovens provide a more efficient method of cooking and re-heating because the food is heated directly, rather than the air in the oven. For very small portions of food being cooked, toaster ovens may be more energy-efficient than full-size ovens.

**Potential Issues:**

Gas ovens and cooktops release combustion products into the house, so proper venting is essential. Many indoor air quality experts recommend against gas cooking equipment for this reason. Electric ovens can be more precisely controlled than gas ovens, and some electric cooktops, especially induction and halogen, respond as rapidly as gas cooktops.

**Related Strategies:**

IDP3, EA105

**References/Resources:**

“Consumer Guide to Home Energy Savings: Cooking”

[www.aceee.org/consumerguide/cooking.htm](http://www.aceee.org/consumerguide/cooking.htm)

## 96. Consider the energy toll of small appliances

**Strategy included in: Kitchen, Living & Working**

The energy consumption of extra consumer appliances – or plug loads – can be significant. In deciding how to outfit a kitchen, include only those appliances and features considered necessary to meet the homeowners’ needs. Reconsider extras like a second dishwasher, second freezer, wine chiller, ice maker, and refrigerator water dispenser. For appliances and features deemed necessary, seek the most efficient.

**Potential Issues:**

Phantom loads (or vampire loads)—the electricity consumed by many pieces of equipment even when turned off—can be significant with many consumer appliances that are plugged.

**Related Strategies:**

IDP3, EA105

**References/Resources:***Consumer Guide to Home Energy Savings*, 9th Edition, ACEEE, 2007, [www.aceee.org](http://www.aceee.org)

“Small Appliances”

[www.consumerenergycenter.org/home/appliances/small\\_appl.html](http://www.consumerenergycenter.org/home/appliances/small_appl.html)

“Home Electronics”

[www.energystar.gov/](http://www.energystar.gov/)

## 97. Choose an efficient hot tub or spa

**Strategy included in: Bathroom**

While hot tubs and spas are not remotely green—due to their considerable water consumption—if one is desired, at least choose the most resource-efficient model possible. A hot tub that is kept filled with water should be well insulated, including a tightly fitting, well-insulated cover. The least-toxic approach for keeping it clean should be employed. For water treatment in this case, look into UV or ozone treatment in place of heavy chlorination. With spas and whirlpool bathtubs that are filled each use, keep the size as small as possible for the given needs.

**Potential Issues:**

Again, the big issue with spas or hot tubs is energy use. Look for other solutions to whatever needs a home hot tub or spa meet.

**Related Strategies:**

IDP3, EA105

**References/Resources:**

“Energy Efficiency Fact Sheet: Hot Tub and Pool Conservation Tips”

[www.energy.wsu.edu/documents/building/res/spatips.pdf](http://www.energy.wsu.edu/documents/building/res/spatips.pdf)

## 98. Manage phantom loads

**Strategy included in: All Projects**

Many—but not all—televisions and other entertainment equipment, as well as office equipment and devices with AC adapters that plug into the wall continue to use power even when “turned off.” At average electricity rates today, every one watt of phantom load (one watt being consumed 24/7) uses about 10 kWh per year and costs homeowners about \$1 per year. Thus, a television or computer monitor using 10 watts when “off” would consume about 100 kWh per year, costing \$10. To be sure that the equipment is really off, there are several options: 1) that equipment can be plugged into power

strips that can easily be switched off when equipment is not being used; 2) certain outlets can be controlled with wall switches to facilitate easy on and off (though accidentally switching off equipment in use can cause problems); or 3) a specialized system can be installed to provide radio-frequency control of selected features, as is possible with the GreenSwitch ([www.greenswitch.com](http://www.greenswitch.com)).

Advise homeowners that when buying a new TV and other equipment, consider both the standby and the operating power consumption. Though there is a lot of variability, for comparable-size screens, LCD models are usually more energy-efficient than CRT (standard picture-tube models using cathode ray tubes), and plasma models are usually less efficient than CRTs. Be aware that digital recording devices, such as TiVo, tend to draw significant power (25–35 watts) even when not recording, and they are typically left on 24/7 to be ready for preset recording. Internet connection equipment, including cable modems and wireless routers are significant electricity users in many homes—often surpassing even televisions. If acceptable to family members, plug these devices into power strips and switch them off at night and when not home. Note that with Voice over Internet Protocol (VoIP) telephone systems, cable modems cannot be turned off without losing phone service.

#### **Potential Issues:**

Most appliances or electronic devices with clocks need to be reset if AC electricity is interrupted; homeowners should be advised of this issue when a switched circuit is being considered to manage phantom loads.

#### **Related Strategies:**

EA96, EA105

#### **References/Resources:**

[www.GreenSwitch.tv](http://www.GreenSwitch.tv)

*Consumer Guide to Home Energy Savings*, 9th Edition, ACEEE, 2007 - [www.aceee.org](http://www.aceee.org)

“Off is a Three-Letter Word”

[www.homeenergy.org/archive/hem.dis.anl.gov/eehem/96/960715.html](http://www.homeenergy.org/archive/hem.dis.anl.gov/eehem/96/960715.html)

## **99. Select energy-efficient Energy Star-rated office equipment**

### **Strategy included in: Living & Working**

With any office equipment that falls into a category for which there are Energy Star listed products, buy only Energy Star-certified products. Along with lower operating energy use, most Energy Star office equipment will go into a power-saving sleep mode, and phantom loads when equipment is turned off are very low.

#### **Potential Issues:**

Energy-saving features, such as sleep mode, can be deactivated by users; encourage homeowners not to change settings to disable energy conservation features.

#### **Related Strategies:**

IDP3, EA105, MR155

#### **References/Resources:**

“Office Equipment”

[www.energystar.gov/](http://www.energystar.gov/)

*Consumer Guide to Home Energy Savings*, 9th Edition, ACEEE, 2007 - [www.aceee.org](http://www.aceee.org)

## **Energy Sources**

### **100. Configure for solar access**

#### **Strategy included in: Addition**

During predesign and design of any remodeling project (but particularly major additions), carefully consider orientation and the potential for solar energy features, including passive-solar heating, daylighting, solar water heating, and photovoltaic (PV) power production. This strategy should start with a careful site assessment to determine access to the southern sky (various site assessment tools are available for carrying out such analysis). To the extent possible, configure the space to benefit from sunlight and control unwanted heat gain. With passive solar heating, this will involve window placement, potential for heat storage within the space, and an interior layout that facilitates natural circulation of solar-warmed air.

#### **Potential Issues:**

With daylighting, care should be taken to avoid unwanted solar heat gain that can result from roof-mounted skylights and west-facing windows. Solar water heating and PV arrays are typically roof-mounted, requiring an unobstructed south-facing roof.

#### **Related Strategies:**

IDP3, SS31, EA45, EA83

#### **References/Resources:**

National Renewable Energy Laboratory - [www.nrel.gov](http://www.nrel.gov)

“Passive Solar Design”

[www.eere.energy.gov/consumer/your\\_home/](http://www.eere.energy.gov/consumer/your_home/)

Solar Today, American Solar Energy Society - [www.ases.org](http://www.ases.org)

### **101. Consider solar water heating**

#### **Strategy included in: Major Addition, Home Performance, Gut Rehab, Deep Energy Retrofit**

Renewable energy systems can make a tremendous difference in improving the environmental performance of a house. Beyond passive solar design and daylighting, solar water heating is often the most cost-effective renewable energy system for residential applications. There are many types of solar water heaters, including flat-plate collector systems with closed-loop antifreeze collector fluid, drainback systems, evacuated-tube



systems, passive thermosiphon systems, and integral-collector-storage systems (batch solar water heaters). Some active solar water heaters use integral photovoltaic (PV) panels to power the pumps, obviating the need for sophisticated controls.

**Potential Issues:**

Most solar water heating systems are fairly expensive, particularly in retrofit situations.

**Related Strategies:**

IDP3, SS31, EA45, EA79, EA104

**References/Resources:**

American Solar Energy Society - [www.ases.org](http://www.ases.org)  
Solar Energy Industries Association - [www.seia.org](http://www.seia.org)  
National Renewable Energy Laboratory - [www.nrel.gov](http://www.nrel.gov)

## 102. Consider a solar electric (photovoltaic) system

**Strategy included in: Major Addition, Home Performance, Gut Rehab, Deep Energy Retrofit**

Photovoltaic (PV) power systems use available sunlight to generate electricity. PV systems work by moving electrons; there are no moving parts. Systems can be very small to provide walkway lights or limited back-up power needs, or they can be large and sophisticated. Some PV systems are designed to feed electricity into the power grid (through net-metering). Others are stand-alone, providing power only to that house and not connected to the utility grid. These stand-alone systems require battery banks to store power for when the sun is not shining. With batteries, control systems, an inverter to operate AC equipment, and panels, a PV system for a home can cost several tens of thousands of dollars.

**Potential Issues:**

PV systems are expensive; be careful not to spend your “greening budget” on high-profile items like PV systems at the expense of more cost-effective energy conservation improvements. A licensed electrician who has experience with PV power systems should be hired for design and installation of a PV system, and proper safety procedures must be followed.

**Related Strategies:**

IDP3, SS31, EA45

**References/Resources:**

“BSC Photovoltaic Primer”  
[www.buildingscienceconsulting.com/resources/homeowner.htm](http://www.buildingscienceconsulting.com/resources/homeowner.htm)  
Solar Energy Industries Association - [www.seia.org](http://www.seia.org)  
“Photovoltaic Basics”  
[www1eere.gov/solar/pr\\_basics.html](http://www1eere.gov/solar/pr_basics.html)

## Use

## 103. Provide a homeowner’s manual of green features and O&M practices

**Strategy included in: All Projects**

Leading builders today are providing a homeowner’s manual when they complete a new house; the same should be provided for a significant remodeling project. This is a place to explain how systems work, compile all equipment and appliance owner’s manuals into a single binder, provide photographs showing wall framing before walls are closed in, list the contractors and subcontractors with contact information in case they need to be reached, describe special maintenance requirements (such as seasonal cleaning of solar collector panels), and offer safe, healthy cleaning recommendations. A lot of effort goes into creating a green, healthy addition or remodel; to ensure that the space remains green and healthy, it is necessary for homeowners to practice green cleaning practices. In a homeowner’s manual, these cleaning practices can be described, and lists of specific cleaning products can be provided.

**Potential Issues:**

None

**Related Strategies:**

IDP6, IDP12, EA104, EA105

**References/Resources:**

“Model Green Homebuilding Guidelines: User Guide-Operation”  
[www.nahbr.org/greenguidelines/userguide\\_homeowner\\_manual.html](http://www.nahbr.org/greenguidelines/userguide_homeowner_manual.html)

## 104. Complete client education

**Strategy included in: All Projects**

If green remodeling moves the home to higher performance, then the project must also move the occupants to higher levels of performance as well. Much of the energy savings and many of the improvements to comfort and indoor air quality initiated by building improvements need to be supported by changes in occupant behavior. Exhaust fans need to be turned on, lights need to be turned off, regular maintenance needs to be scheduled for key equipment. While the weatherization community may have taken the lead on client education, it is work from which all green remodeling professionals can learn and upon which they can build.

**Potential Issues:**

Any template homeowner education manual will need to be customized by the green remodeling professional, perhaps even by project type. But having a master document from which to draw and customize means that issues are less likely to be missed and the homeowner left with something that has their stamp on it.

**Related Strategies:**  
EA103, EA105

**References/Resources:**

“Home Energy Guide.”  
Calif. Energy Commission. Publication #400-99-003  
(compliant with Title 24 requirements)

CMHC “Homeowner’s Manual”  
[www.cmhc-schl.gc.ca/en/](http://www.cmhc-schl.gc.ca/en/)

*The Energy Efficiency Manual*, Donald Wulfinghoff, Energy  
Institute Press, 2000.

## 105. Practice an energy-efficient, healthy lifestyle

**Strategy included in: All Projects**

Homeowners should be encouraged to alter their lifestyles in ways that reduce energy use and ensure that a home will be as healthy as possible. Specific recommendations to save energy include properly setting back thermostats, limiting water use, closing windows reduce operation of air conditioning or heating systems, closing window blinds to reduce unwanted heat gain, using a ceiling fan to increase summertime comfort without air conditioning, turning off a ceiling fan when leaving a room, turning off lights when not in a room, and making use of task lighting while keeping ambient light levels lower. Practices to keep houses healthy include wiping feet when entering and/or removing shoes, avoiding overwatering plants, operating bath and rangehood fans when generating moisture or cooking odors, avoiding smoking in or even next to the house, and avoiding excessive perfume use.

**Potential Issues:**

In speaking with homeowners about lifestyle and behavioral issues, be careful not to sound preachy, as that can turn people off. Explain the benefits of such actions, but leave it up to homeowners to follow these suggestions or not.

**Related Strategies:**  
EA103, EA104

**References/Resources:**

“Sustainable Lifestyles”  
[www.greenhomeguide.org/](http://www.greenhomeguide.org/)

## 106. Provide for line drying options for laundry

**Strategy included in: Bathroom, Outdoor Living**

Clothes drying consumes a significant amount of energy, yet fewer and fewer people today dry clothes on lines. Outdoor clothes lines provide the cleanest, lowest-energy option for drying clothes—and provides homeowners with an opportunity to spend time outdoors (which is healthy in and of itself). If outdoor clothes drying is not

an option, it is often possible to dry laundry indoors, though space and humidity concerns may be a concern.

**Potential Issues:**

Avoid drying clothes indoors in humid climates or during seasons when humidity levels in a house are elevated. Be aware that covenants in many subdivisions do not permit hanging clothes outdoors.

**Related Strategies:**  
IDP3, SS31, EA105

**References/Resources:**

“Project Laundry List”  
[www.laundrylist.org/index2.htm](http://www.laundrylist.org/index2.htm)

## Materials and Resources (MR)

### General Design and Construction Strategies

## 107. Manage construction and demolition waste

**Strategy included in: All Projects**

It makes good environmental sense to minimize solid waste during construction—because landfills are filling up, incineration of construction and demolition (C&D) waste generates pollution, and such waste represent lost resources. The first priority should be to minimize the generation of construction waste. This can be done during design by optimizing dimensions to reduce cut-off waste, and it can be done on the job site through careful use of materials. Second, C&D waste materials that are generated on the job site should be sorted and stored for salvage and reuse, or recycling. As part of a Waste Management Plan, research what the salvage and recycling options are for different materials, and designate storage receptacles accordingly. A local municipal solid waste agency should be able to help you identify these disposal options.

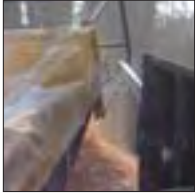
Additionally, it is good practice, common sense, and good public relations to recycle consumer materials on the job site, such as glass/plastic/aluminum beverage containers and paper products. Arrangements can be made to use either the client’s recycling containers or designate a crew member to handle municipal recyclables.

**Potential Issues:**

Good waste management plans for remodeling are especially challenging because of the lack of space on the job site, the smaller quantities of new construction waste material, the complications of what can be a huge amount of demolition waste, and finally, hazardous waste management. On the other hand, remodeling projects present increased opportunities for salvage and reuse.

## Images:

- On-Site Recycling of Clean Wood Waste
- Clean Woodwaste From a Remodel



## Related Strategies:

SS39, MR108, IEQ158, IEQ159, IEQ162

## References/Resources:

EPA C&D Waste Management  
[www.epa.gov/epaoswer/non-hw/debris-new/index.htm](http://www.epa.gov/epaoswer/non-hw/debris-new/index.htm)  
Building Materials Reuse Association - [www.buildingreuse.org/](http://www.buildingreuse.org/)  
"Construction Waste"  
[www.toolbase.org](http://www.toolbase.org)

## Site

### 108. Consider reuse of existing materials

#### Strategy included in: Outdoor Living

Just as there is tremendous potential to use salvaged materials indoor, outdoor living spaces and landscape features offer lots of opportunity to use salvaged materials outdoors. Patios can be made from salvaged stone or brick. Retaining walls can be made from a wide range of salvaged materials, including railroad ties and pieces of broken concrete slabs (called "urbanite" by some green builders). Outdoor decks and railings can be made from decay-resistant salvaged woods, such as cypress, redwood, longleaf yellow pine, black locust, and various tropical hardwoods.

#### Potential Issues:

Whenever using salvaged wood or concrete, consider contamination. Do not reuse wood that has lead paint on it or has been treated with persistent pesticides. Determine the source of salvaged concrete slab material and avoid concrete floor slabs from industrial facilities where toxins may have been spilled and absorbed into the concrete. Only use creosote-treated timbers in locations where offgassing from the material will not get indoors or affect outdoor living areas.

#### Image: Salvaged Roofing Tiles



## Related Strategies:

IEQ158, IEQ159

## References/Resources:

Building Materials Reuse Association - [www.buildingreuse.org/](http://www.buildingreuse.org/)

### 109. Consider a patio rather than a wooden deck

#### Strategy included in: Outdoor Living

Treated wood has traditionally been one of the least-green materials used in and around homes. While today's pressure-treated woods are less toxic than their predecessor (chromated copper arsenate or CCA), they may still leach copper compounds that are toxic to many aquatic organisms, and their expected life outdoors is usually no more than ten years, creating a disposal problem. Wood-plastic composite decking and 100% plastic decking should outlast pressure-treated wood, but many homeowners dislike the look and feel of plastic or are concerned about flammability. A greener alternative is a stone or brick patio. Properly designed and installed, a patio will long outlast a wooden deck, and it has none of the flammability concerns of a wood-plastic composite or all-plastic deck. Patios can be very effectively integrated into other landscape features, such as stone walls, stairs, trellises, and garden areas.

#### Potential Issues:

Patios can be hard with uneven surfaces, a potential cause for concern for seniors or young children.

## Related Strategies:

IDP7

## References/Resources:

"Reduce Impervious Surfaces"  
[www.recycleworks.org/greenbuilding/sus\\_impervioussurfaces.html](http://www.recycleworks.org/greenbuilding/sus_impervioussurfaces.html)

### 110. Use naturally rot-resistant, responsibly produced wood for decks

#### Strategy included in: Outdoor Living

Different species of wood vary tremendously in their rot resistance. Some domestic hardwoods, such as black locust, and a number of tropical hardwoods, such as ipé, teak, and certain mahoganies, will significantly outlast standard pressure-treated wood, and they may even outlast plastic decking. The challenge with these woods, especially those of tropical origin, is ensuring that they were produced in responsibly managed forests. The best way to ensure responsibly sourced wood is to specify wood from forests certified according to Forest Stewardship Council (FSC) standards. Some resistant woods may also be available from salvaged sources.

**Potential Issues:**

If using salvaged sources of durable wood, make sure it has not been treated with persistent pesticides or other toxic chemicals.

**Related Strategies:**

IDP28, MR108

**References/Resources:**

“Wood Handbook”

USDA Forest Products Laboratory -

[www.fpl.fs.fed.us/documnts/fplgtr/fplgtr113/fplgtr113.htm](http://www.fpl.fs.fed.us/documnts/fplgtr/fplgtr113/fplgtr113.htm)

“Protecting Wood Fences for Yard and Garden”

[www.treesearch.fs.fed.us/pubs/5700](http://www.treesearch.fs.fed.us/pubs/5700)

## 111. Choose less harmful pressure treated lumber

**Strategy included in: Major Addition, Outdoor Living**

The most common pressure-treated lumber for decks today uses copper as the active ingredient (either ACQ or copper azole). Other treatments include borates (which are not water resistant) and a new generation of light organic solvent preservatives (LOSPs), for which not a great deal is known about long-term performance or health concerns. The greenest option for treated-wood decking today, involves a sodium silicate/heat treatment. The resulting material, available in some parts of the country, is nontoxic and highly resistant to insects and decay.

**Potential Issues:**

The greenest option for pressure-treated wooden decks, the process using sodium silicate followed by heat treatment, is not yet widely available in most of the country.

**Related Strategies:**

IDP28, IEQ162

**References/Resources:**

TimberSIL - [www.timbersilwood.com](http://www.timbersilwood.com)

REGREEN Product Selection Resources -

[www.regreenprogram.org](http://www.regreenprogram.org)

## 112. Use recycled content plastic or composite decking boards

**Strategy included in: Outdoor Living**

Wood-plastic composite decking and 100% plastic decking will outlast most treated wood decking. Some of these plastic-composite and 100% plastic decking products are also made of recycled material. The most common recycled plastic in decking is high-density polyethylene (HDPE). Some of the composite decking products also contain reclaimed wood—typically sawdust or mill waste from lumber mill operations.

**Potential Issues:**

Some of the manufacturers of wood-plastic composite and plastic decking that used to make extensive use of recycled plastic have switched to virgin plastic, so these products are no longer as “green” as they had been. There is also growing concern about flammability with plastics in decking—if a barbecue grill tips over, hot coals can quickly ignite such decks.

**Related Strategies:**

IDP28

**References/Resources:**

California Integrated Waste Management Board’s Recycled Content Product Directory - [www.ciwmb.ca.gov/RCP/](http://www.ciwmb.ca.gov/RCP/)

REGREEN Product Selection Resources -

[www.regreenprogram.org](http://www.regreenprogram.org)

## 113. Use environmentally preferable patio materials

**Strategy included in: Outdoor Living**

In many respects, patios are far greener than decks. They last longer, the risk of damaging the house due to moisture intrusion is lower, and the materials used in construction are often greener. Look for local stone or salvaged material (stone or brick) to build a patio. Also consider porous materials for a patio—either the materials themselves (porous grid pavers, for example) or how the patio surfacing is installed (providing free-draining crushed stone between and under stone or brick).

**Potential Issues:**

Be aware that locally bought stone may not be local. A lot of the stone being sold in the U.S. today comes from Brazil and even China. The transportation energy and environmental burdens of bringing in stone from foreign countries outweigh most of the environmental benefits of decks.

**Image: Site-Processed Materials****Related Strategies:**

IDP14, MR108, MR109

**References/Resources:**

California Integrated Waste Management Board’s Recycled Content Product Directory - [www.ciwmb.ca.gov/RCP/](http://www.ciwmb.ca.gov/RCP/)

REGREEN Product Selection Resources -

[www.regreenprogram.org](http://www.regreenprogram.org)



## Foundation

### 114. Use fly ash in concrete

#### Strategy included in: Major Addition

Portland cement, which comprises about 12 percent of most concrete, is highly energy-intensive to manufacture, and its production releases significant quantities of carbon dioxide (both from the energy of manufacture and from the chemical process of calcining limestone). In fact, approximately 6% of the world's carbon dioxide emissions result from portland cement production. One way to reduce the environmental burdens of foundations is to use concrete that contains a percentage of fly ash (or other pozzolans such as blast furnace slag) in place of portland cement. Fly ash is a waste product from coal-fired power plants. Mixes with 15%-25% Type C or Type F fly ash are fairly common, and mixes as high as 60% are sometimes used.

One approach in moving to fly ash-content concrete is to check with local or regional Departments of Transportation to see what fly ash mixes they have tested and support. This type of information can go a long way in gaining local support, both from the building inspection department, the ready mix supplier, and the concrete contractor

#### Potential Issues:

The use of fly ash in residential concrete is still relatively new; be sure to find a ready-mix concrete provider who is familiar with fly ash mixes and can advise about any differences in installation and performance.

There are different types and grades of fly ash and blast furnace slag and their quality and qualities can vary widely. Some of these materials come from manufacturing or energy production activities here in the United States, but increasingly these materials are being imported from overseas due to supply and demand issues.

#### Related Strategies:

EA47

#### References/Resources:

*Making Better Concrete*, Bruce King, Chelsea Green Publishing, 2006  
[www.buildersbooksource.com/cgi-bin/booksite/21165.html](http://www.buildersbooksource.com/cgi-bin/booksite/21165.html)  
"Fly Ash Concrete"  
[www.toolbase.org](http://www.toolbase.org)

### 115. Use biobased form-release agent or permanent forms

#### Strategy included in: Major Addition

Standard form-release agents (used to allow concrete formwork to be easily removed from concrete footings and walls after concrete has set) are made from petroleum. Some of this oil seeps into the ground around

the foundation, and some remains on the concrete after the forms are removed—where it can contribute to indoor air pollution. A new generation of form-release agents are made from vegetable oils; these biodegrade naturally and are less harmful in the indoor air. An alternative to removable concrete forms are insulated concrete forms (ICFs), which are made from polystyrene insulation. They remain in place permanently and provide insulation on both the interior and exterior of the foundation wall. While ICFs are most commonly used for foundation walls, they are sometimes used to construct the entire wall of a house or addition.

#### Potential Issues:

Bio-based form release agents generally come at a substantial price premium.

#### Related Strategies:

EA47

#### References/Resources:

REGREEN Product Selection Resources -  
[www.regreenprogram.org](http://www.regreenprogram.org)

## Building Envelope

### 116. Minimize wood use with Advanced Framing or SIP construction

#### Strategy included in: Major Addition, Gut Rehab

Conventional wood framing uses 15% to 20% more framing lumber than is structurally required. Extra studs at corners and wall intersections, cripple studs, solid-wood headers (flanked with two-by plates top and/or bottom), double top-plates, and 16-inch-on-center stud spacing are all overkill, according to proponents of *Advanced Framing*. By switching to 24-inch studs and roof trusses or rafters, switching from a double to a single top plate (and aligning roof trusses or rafters with wall studs), eliminating superfluous studs, and replacing solid-wood headers above windows and doors with engineered (and insulated) headers, wood use can be reduced and insulation performance can be increased (because insulation insulates at least three times better than wood). Advanced framing also saves money by reducing wood use. Structural insulated panels (SIPs) go beyond advanced framing by eliminating framing lumber altogether for the exterior envelope. With SIPs, panels of oriented strand board surround a core of rigid insulation (usually EPS or polyurethane); they insulate extremely well and—if properly installed—result in a very tight envelope.

#### Potential Issues:

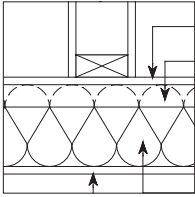
In going from 16-inch to 24-inch on-center wall and ceiling framing, some contractors prefer using 5/8-inch drywall. There is typically a bit of a learning curve

(sometimes more than a bit) in moving framers over to advanced framing techniques.

### Image: Advanced Framing on Interior Partitions

#### Details: Advanced Framing

- Ladder blocking
- Intersecting wall details (5)
- Corner details (8)
- Stacked frame elevation



#### Related Strategies:

IDP3, EA48

#### References/Resources:

*Efficient Wood Use in Residential Construction*, NRDC, 1998

“Using Wood Efficiently”

[www.buildingscienceconsulting.com/resources/misc/](http://www.buildingscienceconsulting.com/resources/misc/)

## 117. Use high-recycled-content, formaldehyde-free insulation

### Strategy included in: Major Addition, Gut rehab, Deep Energy Retrofit

All fiberglass today contains at least 25 percent recycled glass, most of which is from the window glass manufacturing industry, but some is from recycled beverage glass. In fact, the insulation industry is now the largest user of recycled glass in the country. Cellulose insulation, however, contains a significantly higher recycled content: typically 80% post-consumer recycled newspaper (the remainder being borate and/or ammonium sulfate flame retardants). Most fiberglass insulation is produced using phenol formaldehyde binders that hold the fibers together. While most of the free formaldehyde is driven off during a baking process, residual formaldehyde may still be released into a home. Formaldehyde was reclassified in 2004 by the International Agency for Research on Cancer (IARC) from being a “probably human carcinogen” to being a “known human carcinogen,” raising greater concern about formaldehyde from fiberglass. At least one major fiberglass manufacturer has switched production to a non-formaldehyde acrylic binder. While polystyrene, polyisocyanurate, and spray polyurethane insulation do not contain significant recycled content, they do not contain formaldehyde. Of the insulation materials available today, only extruded polystyrene (XPS) is still made with an ozone-depleting blowing agent—with phase-out scheduled for 2010.

#### Potential Issues:

Because the majority of insulation’s environmental impact is its contribution to reduced energy consumption of the building, the material’s applied performance should always be considered before other features like high-recycled content.

#### Related Strategies:

EA48, EA49

#### References/Resources:

“Insulation: Thermal Performance Is Just The Beginning”  
[www.buildinggreen.com/auth/article.cfm?fileName=140101a.xml](http://www.buildinggreen.com/auth/article.cfm?fileName=140101a.xml)

REGREEN Product Selection Resources -  
[www.regreenprogram.org](http://www.regreenprogram.org)

## 118. Use FSC-certified wood

### Strategy included in: All Projects

The best way to ensure that wood used in remodeling projects or additions was produced in an environmentally responsible manner is to specify Forest Stewardship Council (FSC) certified products. FSC has established rigorous standards for forest management and a process for third-party certification of those forests and products derived from them.

#### Potential Issues:

Most (but not all) FSC-certified wood products will be more expensive than non-certified products, because of the cost of carrying out third-party certifications of forest operations and chain-of-custody certifications of products coming from those forest operations. Obtaining a consistent, ready supply of FSC-certified wood products may also be a problem; supply and distribution of various FSC-certified materials varies widely by region.

A strong second option is to use 3<sup>rd</sup>-party certified SFI materials, with a third option being SFI materials.

#### Related Strategies:

MR134, MR147

#### References/Resources:

Forest Stewardship Council - [www.fscus.org](http://www.fscus.org)

Scientific Certification Systems - [www.sccertified.com/](http://www.sccertified.com/)

SmartWood Program of the Rainforest Alliance -

[www.rainforest-alliance.org/forestry.cfm?id=certification](http://www.rainforest-alliance.org/forestry.cfm?id=certification)

Sustainable Forestry Initiative - [www.sfiprogram.org/](http://www.sfiprogram.org/)

## 119. Install a durable wall cladding

### Strategy included in: Major Addition, Deep Energy Retrofit

Choices with siding affect the moisture management, long-term durability, and maintenance needs of a house exterior. With any moisture-permeable siding material (wood, fiber cement, brick), an air space

behind the siding is highly recommended. With wood or fiber cement siding, this air space or rainscreen can be provided with strapping that is perpendicular to the siding or a specialized drainage/rainscreen material designed for this application. Properly finished and installed over a rainscreen, wood or fiber cement siding should require far less frequent painting or staining than when installed directly over sheathing. In fire-prone areas, a noncombustible siding, such as fiber cement, can provide important building protection, but must be coupled with fire-resistant screening of the air space behind the cladding to be effective.

Properly finished means all cut edges primed with a preference for factory pre-primed claddings.

#### **Potential Issues:**

Some of the environmental impact from siding happens every time that siding is painted or stained, so measures to reduce the need for refinishing can improve the environmental performance significantly. The air space between the cladding and the wall sheathing can make for challenging jamb extensions at windows and doors.

#### **Related Strategies:**

IDP1, IDP24, IDP25

#### **References/Resources:**

“Siding Question/Rainscreen Question”  
[www.buildingscienceconsulting.com/resources/walls/](http://www.buildingscienceconsulting.com/resources/walls/)  
“Exterior Ventilated Cladding”  
[www.uaf.edu/ces/publications/freepubs/HCM-01558.pdf](http://www.uaf.edu/ces/publications/freepubs/HCM-01558.pdf)

### **120. Provide a durable, reflective roof**

#### **Strategy included in: Major Addition, Deep Energy Retrofit**

Roofs are exposed to the most stressful conditions of any component of a house: tremendous temperature fluctuation, UV light, rainstorms, and high wind. Their long-term performance in excluding precipitation is critical to the long-term durability of a house, and a roof can be a source of significant unwanted heat gain. Roofing is also one of the largest components of C&D waste today, especially short-lifespan asphalt shingles. A highly durable, 50-year roof is recommended for any green addition or in re-roofing a house. To reduce unwanted heat gain, provide a high level of insulation in the ceiling or roof assembly, and also consider a reflective roof. With a reflective roof, look for a roofing material that is certified by EPA’s Energy Star Roof program. While a reflective roof may reduce air conditioning costs in a home, it also helps to reduce the “urban heat island effect” (the regional warming that occurs as a result of dark paved areas and buildings).

#### **Potential Issues:**

If a roof is to be used for potable water collection, a material should be used that does not capture and hold contaminants (such as asphalt or fiberglass with a textured surface), and the roof should not result in leaching of contaminants into the water, as can be the case with copper and certain other materials.

#### **Related Strategies:**

IDP1, IDP24, IDP25

#### **References/Resources:**

EPA Energy Star roofing products -  
[www.energystar.gov/](http://www.energystar.gov/)

## **Lighting and Electrical**

### **121. Plan for the future with wiring and cabling needs**

#### **Strategy included in: Living & Working, Major Addition, Gut Rehab, Deep Energy Retrofit**

Cabling is an important issue in any 21st century home, but especially in any space that could be used as a home office. Living rooms, too, need to meet more and more needs when it comes to cabling, including sophisticated audio and visual systems. We have seen dramatic changes in the needs for both electrical and communications/data cabling in the past two decades—particularly communications and data, from standard phone lines to Ethernet to T-1 and fiber-optic. It is hard to predict what the needs will be in five years; indeed, it is possible that wireless technology will obviate the need for communications and data cabling altogether. To plan for the unknown and minimize the likelihood of expensive cabling upgrades in the future, it is advisable to provide either wiring conduit through which new cables can be run, or surface-mounted wiring raceways that is highly accessible for homeowner modifications. In addition to planning for adaptability, provide plenty of electrical receptacles and communications ports to provide flexibility within these spaces.

#### **Potential Issues:**

Raceways erode usable floor area ever so slightly. The main issue is height requirements for outlets (off the floor) and issues of universal design.

#### **Image: Baseboard Wiring Raceway with SIP Walls**



#### **Related Strategies:**

IDP7

## References/Resources:

“Electrical Raceways”  
www.toolbase.org

## Plumbing

### 122. Consider the environmental preferability of piping material

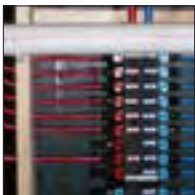
#### Strategy included in: Kitchen, Bathroom,

Of the most common piping materials used in homes today—copper, CPVC, and PEX (cross-linked polyethylene), PEX is often considered the greenest. PEX is a plastic containing only carbon and hydrogen atoms, so its manufacture and disposal is relatively clean. While most copper pipe contains fairly high recycled content, the mining required to produce virgin copper is environmentally damaging, and all copper is highly energy-intensive to produce. Home-run piping systems are becoming increasingly common; they have a central manifold near the water heater with separate PEX tubing lines running directly to each fixture or appliance. This configuration offers the benefit of matching the tubing diameter to the usage of each fixture. The diameter of a tubing line for a bathroom faucet can be kept small (say  $\frac{3}{8}$ " diameter), so hot water will reach the faucet quickly and losses will be minimized—while a bathtub will be served by larger-diameter tubing. If copper is used in a more conventional pipe distribution network, the hot-water pipes should be insulated to retain heat in the pipes longer between uses. (Some even recommend insulating PEX tubing, though because the tubing diameter is matched with the usage and because the PEX tubing has lower conductivity than copper, insulating the tubing is not quite as important.

#### Potential Issues:

Some local jurisdictions have shown resistance to PEX tubing for domestic water supply (as opposed to PEX tubing for radiant heating systems) because of confusion between PEX and other plastic tubing systems and because of concerns regarding the leaching potential from soil into PEX tubing (in some slab-on-grade applications). Also, efficient plumbing design (clustering of hot water draw locations) is the best way to achieve plumbing pipe efficiency, although in remodeling there is certainly less opportunity for plumbing distribution redesign.

#### Image: PEX Piping Manifold



## Related Strategies:

EA77

## References/Resources:

Copper Development Association -  
www.copper.org/environment/homepage.html  
Plastic Pipe Institute - www.plasticpipe.org  
“Piping in Perspective: Selecting Pipe for Plumbing in Buildings”  
www.buildinggreen.com/auth/article.cfm?fileName=160401a.xml

### 123. Include a plumbing access panel

#### Strategy included in: Bathroom

To facilitate inspection and repairs to plumbing components, it makes a great deal of sense to provide a plumbing access panel in a bathroom, kitchen, or other space where significant plumbing lines are run. The access panel should be located to permit access to as much plumbing as possible—especially for piping that is most likely to require future modification or repairs. Most common are access panels that open into walls with pipes serving showers and baths.

#### Potential Issues:

A plumbing access door that penetrates a wall's air barrier should be well constructed and tight-sealing to prevent it from being a source of air and moisture movement into the wall cavity.

## Related Strategies:

EA77

## References/Resources:

(Type “plumbing access panel” into any browser)

### 124. Install readily accessible, single-throw shut-off valve

#### Strategy included in: Bathroom

Water pressure—both hot and cold—is maintained 24/7 in a clothes washer unless the shut-off valves are closed. This means that if a hose starts to leak or bursts, water will flow unabated until someone discovers the leak or flood. Installing a single-throw shut-off valve in a readily available location means that all water supplied to the clothes washer can be turned on and off, like a light switch, to prevent flooding or to quickly shut off water if a leak or burst hose occurs. The single-throw lever turns off both the hot and cold supply in one motion.

#### Potential Issues:

A location for the single-throw shut-off that is handy but not prominent can be an aesthetic issue, depending on the location of the clothes washer.



### Image: Single-Throw Clothes Washer Shut-Off



#### Related Strategies:

EA92, MR125

#### References/Resources:

“Read This Before You Design, Build, Or Renovate”

[www.buildingscienceconsulting.com/resources/mold/](http://www.buildingscienceconsulting.com/resources/mold/)

[www.plumbingwarehouse.com/clotheswasherhoseshtutoff.html](http://www.plumbingwarehouse.com/clotheswasherhoseshtutoff.html)

### 125. Install drain and drain pan for clothes washer located over finished space

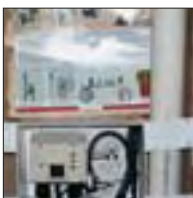
#### Strategy included in: Bathroom

More and more, clients want the laundry room located in a finished space, on the 1st floor or even the 2nd floor instead of the basement space or in a utility room. This means that the clothes washer is located around and over finished space where a burst or leaking hose or washer drum can result in catastrophic water damage. Installing the clothes washer on a shower pan, plumbed for drainage, is a smart strategy for reducing risk and increasing service life.

#### Potential Issues:

Sizing of the pan must be coordinated with the selection of the clothes washer, and the pan must be in the rough plumbing layout.

### Image: Electronic Leak Detection for Clotheswasher



#### Related Strategies:

MR124

#### References/Resources:

“Checklist for Decay Resistance”

[www.lsuagcenter.com/en/family\\_home/home/la\\_house/my\\_house/Durable/](http://www.lsuagcenter.com/en/family_home/home/la_house/my_house/Durable/)

“Clotheswasher Drain Pan Specifications”

[www.floodsaver.com/24\\_Specs.htm](http://www.floodsaver.com/24_Specs.htm)

## Walls and Ceilings

### 126. Install environmentally preferable interior sheathing

#### Strategy included in: Kitchen, Bathroom, Basement

Select drywall (wallboard) products with a high recycled content and use taping materials and joint compound without hazardous additives that aid drying and setting. Conventional, paper-faced drywall is a fairly good material from an environmental standpoint (recycled paper facing and low offgassing of pollutants). Drywall is also available made from flue-gas desulfurization gypsum (a waste product from pollution control equipment on coal-fired power plants). In high-moisture areas, specify drywall products that are more resistant to moisture, such as non-paper-faced products (monolithic and fiberglass-faced drywall is available for high-moisture areas). Drywall materials are becoming available with higher pre-consumer recycled content. In some cases, interior finish panels can be eliminated altogether by using “structure-as-finish” components. For example, if the wall is being made from blocks (such as autoclaved aerated concrete, AAC), a natural clay plaster could be applied directly to that masonry surface, eliminating the need for panelized products altogether.

#### Potential Issues:

During remodeling work, protect both the workers and homeowners by capturing dust during drywall finishing and using temporary fans to maintain negative pressure (and exhaust dust) in the space being finished. To avoid contaminating the heating system, seal registers and the duct work during drywall sanding and finishing.

Recycling opportunities for drywall cut-off waste are generally quite limited; on-site recycling of ground gypsum board as a soil amendment is permissible in many locations.

Low- and zero-VOC joint compound may contain chemical compounds that have adverse health effects for some individuals.

#### Related Strategies:

MR107, IEQ183

#### References/Resources:

ReGreen Reference Guide to Product Considerations - [www.regreenprogram.org](http://www.regreenprogram.org)

### 127. Select environmentally preferable interior doors

#### Strategy included in: Bedroom, Living & Working

When selecting interior doors, consider salvaged and refinished products that may be available from architectural salvage yards, or reuse doors that were in the house after refinishing. With new doors, look

for the following features: ag-fiber (e.g., wheat straw particleboard) core; formaldehyde-free or urea-formaldehyde-free wood components; FSC-certified wood or wood veneers; transom lites to help distribute natural light; and zero-VOC or low-VOC finishes.

**Potential Issues:**

Many of the environmental features described here are not widely available in interior doors, so availability may be an issue. When greener products are found, there may be a cost premium.

**Related Strategies:**

EA83, MR108, MR118

**References/Resources:**

REGREEN Product Selection Resources - [www.regreenprogram.org](http://www.regreenprogram.org)

## 128. Frame for installation of future grab bars

**Strategy included in: Bathroom**

With walls opened up to the studs during a remodel, additional blocking can be added for the installation of grab bars during the current remodel, or called out for a future installation when health issues necessitate. Take photographs of the framing for future reference before installing drywall.

**Potential Issues:**

Care should be taken on exterior walls to maintain thermal performance as blocking is added that replaces insulation—yet another good argument for considering the addition of exterior rigid insulation as a part of any bathroom remodel.

**Related Strategies:**

IDP7, EA48

**Resources/References:**

“Residential Remodeling and Universal Design” [www.huduser.org/publications/destech/resid.html](http://www.huduser.org/publications/destech/resid.html)

“Universal Design” [www.extension.iastate.edu/housing/elderly/udha-ud.html](http://www.extension.iastate.edu/housing/elderly/udha-ud.html)

## 129. Consider alternative wallcovering products

**Strategy included in: Bathroom, Bedroom**

In the past, wallpaper was indeed made from paper, or natural fiber materials backed with paper. Over time, the need for sturdier wallcoverings, mostly for commercial interiors, and more cleanable products for bathroom and kitchen applications, has brought about the development of non-breathable wallcovering made mostly from plastic materials, nearly universally PVC-based. Recent concerns about manufacturing by-products from the PVC industry, and growing awareness about outgassing

characteristics of the plasticizers in PVC-based products, has instigated the industry development of a number of greener wallcovering products. These new wallcovering products include those that are PVC-, plasticizer- and heavy-metal-free, from natural and rapidly renewable materials, including wood pulp, cork, grasses, and other plant fibers. These new wallcoverings are also breathable; they do not act as barriers to trap moisture behind the walls.

**Potential Issues:**

Many wallcoverings create an attractive, durable, and easily-cleaned surface, sometimes more durable than a good wall paint. In areas that are guaranteed continued abuse from furniture and equipment hitting the walls, wallcovering can still be the best option.

**Related Strategies:**

IDP25

**Resources/References:**

“Green From Wall To Wall” [www.edcmag.com/CDA/Archives/8f8837e14c697010VgnVCM100000f932a8c0](http://www.edcmag.com/CDA/Archives/8f8837e14c697010VgnVCM100000f932a8c0)

## 130. Use appropriate sheens for paints and finishes.

**Strategy included in: Kitchen, Bathroom, Bedroom**

In areas that may experience high humidity and where walls will frequently be washed, durable paints with high “scrubability” ratings will ensure longer life. In these applications, painters long preferred oil-based enamel paint, but newer high-sheen, water-borne acrylic paints are now available with excellent performance in these applications. As with all paints, look for low VOC levels.

**Potential Issues:**

Thick layers of higher sheen paints might act as a vapor barrier on the inside of walls, and trap moisture behind.

**Related Strategies:**

IDP1

**References/Resources:**

“Selecting Healthy and Environmentally Sound Finishes” [www.bayarea.greenhomeguide.com/index.php/knowhow/entry/760/C224](http://www.bayarea.greenhomeguide.com/index.php/knowhow/entry/760/C224)

## 131. Consider natural finishes

**Strategy included in: Bedroom, Living & Working**

Natural paints, varnishes, oil finishes, and plasters provide more natural alternative to conventional petroleum-based finishes. A wide range of such products are on the market, though many will not be available locally. Natural pigments often provide the colors, so options may be somewhat limited. Many of the plant-based paints and oils are produced in Europe, as are

some of the lime and clay plasters. Be sure to follow manufacturers' instructions for installation and apprise homeowners of care and maintenance requirements.

**Potential Issues:**

Natural finishes tend to be more labor intensive to apply and more expensive. Many natural finishes are not as moisture-resistant as acrylic and polyurethane finishes. Also, some of the natural, plant-based finishes can contain natural terpenes and other ingredients that chemically sensitive people cannot tolerate.

**Related Strategies:**

EA103, IEQ196

**References/Resources:**

"Selecting Healthy and Environmentally Sound Paints"  
[www.bayarea.greenhomeguide.com/index.php/knowhow/entry/750/C224](http://www.bayarea.greenhomeguide.com/index.php/knowhow/entry/750/C224)

### 132. Consider tile and tile trim pieces with recycled content

**Strategy included in: Kitchen, Bathroom**

Ceramic and porcelain tile is available with high recycled content. Some products are made entirely from recycled glass, others from pre-consumer recycled industrial waste (such as tailings from mining operations). Some recycled-content tile are available with unique stories—recycled window glass from a particular building, for example, or a certain type of recycled beverage glass.

**Potential Issues:**

Recycled content tile is available in limited styles and types, although inventories are growing.

**Related Strategies:**

MR156

**References/Resources:**

"Green Buyer's Guide To Stone & Tile"  
[www.bayarea.greenhomeguide.com/index.php/knowhow/entry/642/C225/](http://www.bayarea.greenhomeguide.com/index.php/knowhow/entry/642/C225/)

## Floors and Flooring Products

### 133. Consider reuse of existing flooring and subflooring

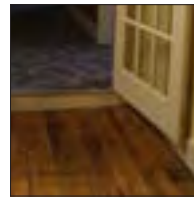
**Strategy included in: Kitchen, Bathroom**

An attractive environmental solution is to refinish an existing floor that has structural integrity and is made from a safe product, such as hardwood or concrete. Attention should be paid to ensure that an older wooden floor being refurbished does not have lead-based paint. New grinding and hardening technology is allowing old concrete slabs to be turned into beautiful polished-concrete floors.

**Potential Issues:**

Existing finished flooring should be assessed for hazardous material content (lead and asbestos, primarily) and subflooring should be assessed for its structural integrity. See EPA or HUD resources for managing materials such as lead- and asbestos-containing materials in the home.

**Image: Birch Flooring Reused**



**Related Strategies:**

IEQ159, IEQ160

**References/Resources:**

National Wood Flooring Association - [www.woodfloors.org/consumer/maintRenewal.aspx](http://www.woodfloors.org/consumer/maintRenewal.aspx)

"Asbestos In Your Home"  
[www.epa.gov/asbestos/pubs/ashome.html#4](http://www.epa.gov/asbestos/pubs/ashome.html#4)

"Lead Paint Safety: A Field Guide for Painting, Home Maintenance, and Renovation Work"  
[www.hud.gov/offices/lead/training/LBPguide.pdf](http://www.hud.gov/offices/lead/training/LBPguide.pdf)

### 134. Select wood subflooring that is FSC-certified and low-formaldehyde

**Strategy included in: Bedroom**

To ensure the most environmentally friendly and healthiest wood subflooring, use product that has been certified according to standards of the Forest Stewardship Council (FSC). For wood-panel subflooring, such as particleboard, select product that is not made with urea-formaldehyde binder and that meets the forthcoming California Air Resources Board (CARB) standards for formaldehyde emissions.

**Potential Issues:**

FSC-certified and non-UF formaldehyde may be difficult to find, and it will likely be priced above standard subflooring.

**Related Strategies:**

MR118

**References/Resources:**

"Formaldehyde in the Home"  
[www.arb.ca.gov/research/indoor/formaldbg108-04.pdf](http://www.arb.ca.gov/research/indoor/formaldbg108-04.pdf)  
Forest Stewardship Council - [www.fsc.org](http://www.fsc.org)

### 135. Consider flooring made from certified or reclaimed wood

#### Strategy included in: Kitchen, Bedroom

Wood use in buildings is enormous. Careful consideration should go into researching the correct type of wood for dimensional stability, the quantity of wood use with a goal of minimizing use and waste, and the source and the species of wood (avoiding sourcing endangered wood or wood from a fragile ecosystem). Each of these areas of concentration takes effort.

Reuse of wood in appropriate situations is ideal, assuming the wood is dimensionally stable and does not have any lead paint. Sourcing reused or reclaimed wood is another good way to reduce wood use.

When new wood must be purchased, the highest standards in wood production and harvesting practices is overseen by the Forest Stewardship Council. Their logo “FSC” can now be found more often on wood and wood products at major and specialty home improvement stores.

Tree-farmed or plantation grown woods, such as teak, are better than extracting trees from delicate forests, but most of these farming operations lack natural healthy forest ecosystems, and must rely on added fertilizers and pesticides to maintain appropriate growth and vitality.

#### Potential Issues:

Assure that reclaimed woods do not have old lead-based finishes. Some wood certification programs are more stringent than others, and some are backed by “chain of custody” paperwork to “guarantee” their certification.

#### Related Strategies:

MR118

#### References/Resources:

REGREEN Product Selection Resources - [www.regreenprogram.org](http://www.regreenprogram.org)

### 136. Consider flooring made from natural or rapidly renewable materials

#### Strategy included in: Kitchen, Bedroom

Products made using fast-growing and under-utilized agricultural materials take strain off wood and lumber use. Sheet products made from wheat, recycled waste paper and resins, and more exotic paneling made from plants such as waste “sorghum” stalks can make unique and more environmentally benign products.

Our popular trend to use bamboo for flooring and paneling is a good use of a very rapidly growing plant product.

Cork and true linoleum are two flooring products that are durable and good substitutes to other mainstream

kitchen flooring products. Cork flooring is made from the bark peeled off Spanish Oak trees. It gives cushioning under foot and has good sound mitigation qualities. Natural linoleum is made much the way it has been for decades and contains wood and cork flours, colorants and linseed oil. It is a very durable product, and allows for endless design opportunities.

#### Potential Issues:

Watch for formaldehyde content in glues, and applicability in situations when water might be an issue. Pay attention to manufacturing processes when buying products manufactured overseas. These products may also have odors that could impact sensitive individuals.

#### Related Strategies:

MR137

#### References/Resources:

“Navigating The Flooring Ticket...”  
[www.bayarea.greenhomeguide.com/index.php/knowhow/entry/802/C220](http://www.bayarea.greenhomeguide.com/index.php/knowhow/entry/802/C220)

### 137. Refinish wood floors using environmentally preferable products

#### Strategy included in: Living & Working, Gut Rehab

Reusing existing wood flooring has many positive environmental benefits, including the opportunity to show off beautiful woods that have been “on location” for years. But attention needs to be paid to how floors are refinished. Start by testing for lead paint and, if found, follow accepted practices for stripping or encapsulating the paint. When sanding and refinishing wood floors, provide active dust collection and seal off adjoining parts of the house and any air distribution registers to prevent contamination. When finishing wood floors with coatings, use low-VOC products, such as water borne polyurethane.

#### Potential Issues:

If proper testing is not done and proper care is not taken, refinishing older wooden floors can cause significant building contamination problems, posing a health risk to homeowners.

#### Related Strategies:

IEQ159

#### References/Resources:

“Buyer’s Guide To Clear Finishes”  
[www.greenhomeguide.com/index.php/knowhow/](http://www.greenhomeguide.com/index.php/knowhow/)



## 138. Choose environmentally preferable carpet and rug products

### Strategy included in: Bedroom, Living & Working

Choices for greener carpeting and area rugs include:

- Products made from natural materials, such as wool, cotton, jute, or hemp (but try to avoid wool treated with mothproofing and other pesticides);
- Products that do not contain residues from the dyes and finishes used in manufacturing;
- Products that do not have surface treatments to repel stains;
- Products with low VOC offgassing, documented through independent, third-party testing, such as CRI Green Label Plus, GreenGuard, and FloorScore;
- Products with high recycled content and made by companies that take back old carpeting for recycling.

In addition, avoid carpet cushion that may contain brominated flame retardants (BFRs), such as product made from bonded polyurethane foam. While the amount of BFR has dropped since penta BDE ceased being used in 2005, carpet cushion made from post-consumer recycled polyurethane foam may still contain residual BFR.

Also, once available only for commercial applications, carpet tile is now being produced in residential styles, patterns, and textures. Carpet tile installations allow for the simple replacement of smaller areas of the carpeted areas, which might result from staining, moisture damage, or wear.

#### Potential Issues:

Examine manufacturer claims carefully—some claims are exaggerated and some misleading. While residential carpet tile is now on the market, it is not yet widely available; shopping around may be necessary.

#### Related Strategies:

IEQ179, IEQ182

#### References/Resources:

Carpet and Rug Institute - [www.carpet-rug.org](http://www.carpet-rug.org)

Greenguard Environmental Institute  
[www.greenguard.org](http://www.greenguard.org)

## 139. Select carpet cushion that does not contain brominated flame retardants

### Strategy included in: Bedroom, Living & Working

Flexible polyurethane foam carpet cushion (underlayment) used to contain fairly high levels of brominated flame retardants (BFRs). While the amount of BFR has dropped since penta BDE ceased being used in 2005, carpet cushion made from post-consumer

recycled polyurethane foam may still contain residual BFR. As the polyurethane foam breaks down over time, these BFRs may be released into the house as dust. Various health concerns have been raised about BFRs—enough so that carpet cushion with post-consumer recycled content should be avoided unless the recycled sources are known not to contain BFRs.

#### Potential Issues:

Natural-fiber carpet cushion may be difficult to find or more expensive.

#### Related Strategies:

IEQ182

#### References/Resources:

Carpet and Rug Institute - [www.carpet-rug.org](http://www.carpet-rug.org)

Carpet Cushion Council – [www.carpetcushion.org](http://www.carpetcushion.org)

Greenguard Environmental Institute -  
[www.greenguard.org](http://www.greenguard.org)

## Furniture and Fittings

## 140. Consider reusing clean existing cabinetry or buying salvaged

### Strategy included in: Kitchen

Should the existing or recycled cabinets be in good shape, have a style that you are willing to work with, and can be refinished if needed, reusing cabinets can be a good idea. Some reconfiguring, new finishes, hardware, and sometimes new drawer and door fronts can be practical, and add details, features and storage.

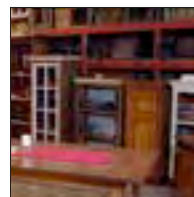
Another good choice for reuse of existing cabinetry is re-facing. If the structural integrity and configuration of the existing cabinetry fits the client's needs, cabinet re-facing is a good investment for the client and the environment.

#### Potential Issues:

Do not let improperly sized and styled cabinets dictate a kitchen design that does not allow you to maximize your design and ideals; make sure cabinets are in good shape, free of lead paint, mold or other toxins.

#### Images:

- Second Hand Bath Counter Top
- Retail Architectural Salvage Center



#### Related Strategies:

IEQ159

## References/Resources:

*Sustainable Residential Interiors*, Foster/Stelmack/Hindman – Associates III

[www.kitchencabinetrefacing.org/](http://www.kitchencabinetrefacing.org/)

“Taking a Green Approach to Furniture”

[www.bayarea.greenhomeguide.com/index.php/knowhow/entry/943/C221](http://www.bayarea.greenhomeguide.com/index.php/knowhow/entry/943/C221)

## 141. Consider reusing clean existing furnishings and fixtures or buying salvaged

### Strategy included in: Bathroom

Using salvaged cabinetry and plumbing fixtures can be a way to reduce the impacts of manufacturing new goods, as well as reducing the amount of material entering landfills. While it makes sense to salvage and reuse certain bathroom fixtures—such as sink basins, tub/shower surrounds, and bathtubs—older, high-water-use toilets should not be reused; newer, top-water-conserving models should be used, such as high-efficiency toilets that use at least 20% less water than the federal maximum of 1.6 gallons per flush.

### Potential Issues:

Along with avoiding older toilets, make sure that older sinks can accommodate faucets with modern screw-in aerators to control water flow. With any painted salvaged product coming from a house built prior to the 1970s, test for lead paint.

### Related Strategies:

IEQ159

### References/Resources:

Building Materials Reuse Organization - [www.buildingreuse.org/](http://www.buildingreuse.org/)

## 142. Consider cleaning existing furniture or purchasing salvaged/antique furniture

### Strategy included in: Bedroom, Living & Working

Antique, salvaged, or re-used furniture and accessories provide a good use of resources, but only if these items are clean and in good condition. Not only do salvaged goods reduce the environmental and energy impacts of manufacturing new goods, but they also reduce the burden on landfills. Be careful to avoid bringing furniture that contains dust, mold or toxic finishes into a newly renovated space. Test painted furniture for lead paint. Thoroughly vacuum and clean any “new” used item outside the home before bringing it into the living space. Use green cleaning products and practices.

### Potential Issues:

The risk of lead contamination is significant with salvaged materials coming from houses built before the 1970s; always test for lead paint and if found, follow accepted best practices for lead paint removal and sealing, or do not install.

## Related Strategies:

IEQ159, IEQ160

## References/Resources:

National Lead Information Center - [www.epa.gov/lead/pubs/nlic.htm](http://www.epa.gov/lead/pubs/nlic.htm)

## 143. Purchase the best, most durable furniture possible within a given budget

### Strategy included in: Bedroom, Living & Working

Purchase tomorrow’s antiques today. Well-made, durable furniture is a good financial investment, is less likely to go out of style than cheaper furnishings, and can be passed on for many generations. Examine workmanship and materials carefully, and consider warranties, which may be indicative of expected life. With wood furniture, look for FSC certification, indicating that the wood came from well-managed forests.

### Potential Issues:

Often, within a given furniture budget, it is possible to get better-quality, more durable furniture by finding older, salvaged goods and spending money on reupholstering or cleaning. (See “Consider reusing clean existing furniture and accessory items, or purchase reused and salvaged furniture.”)

### Related Strategies:

IDP1, MR118, IEQ159, IEQ192

### References/Resources:

*Sustainable Residential Interiors*, Foster/Stelmack/Hindman – Associates III

## 144. Select ergonomic furniture and office equipment

### Strategy included in: Living & Working

Keeping homeowners healthy means looking beyond VOC emissions and control of mold and other contaminants; also consider posture and support when sitting and sleeping. To protect homeowner posture, select ergonomically designed office furniture and seating for living spaces throughout a house. Select beds that will provide back support.

### Potential Issues:

In confined spaces that serve multiple uses, such as living rooms that serve as home offices, the same furnishings may serve multiple roles, so paying attention to ergonomics is particularly important.

### Related Strategies:

IDP6

### References/Resources:

“Computer Workstations” [www.osha.gov/SLTC/etools/computerworkstations/index.html](http://www.osha.gov/SLTC/etools/computerworkstations/index.html)

## 145. Evaluate use of cabinetry and furniture made from particleboard or MDF

### Strategy included in: Kitchen, Basement, Bathroom

Conventional particleboard and medium-density fiberboard (MDF) produced with urea-formaldehyde binder is highly susceptible to moisture damage. Liquid water or even high humidity can swell these panel products, and repeated exposure to moisture can cause delamination or decomposition. Avoid cabinets and furniture made from these materials in moist locations; if they must be used, select more moisture-resistant products, such as particleboard and MDF produced with MDI (polyurethane) or phenol-formaldehyde binders. Most plywood and solid wood are significantly more moisture-resistant than standard particleboard and MDF. Sealing can also help to prevent moisture damage.

### Potential Issues:

Alternatives to urea-formaldehyde particleboard and MDF are more expensive, but in addition to greater moisture resistance, they result in much lower formaldehyde offgassing.

### Related Strategies:

IDP5

### References/Resources:

*Sustainable Residential Interiors*, Foster/Stelmack/Hindman – Associates III

“Taking a Green Approach to Furniture”

[www.bayarea.greenhomeguide.com/index.php/knowhow/entry/943/C221](http://www.bayarea.greenhomeguide.com/index.php/knowhow/entry/943/C221)

## 146. Select compact furniture that incorporates storage

### Strategy included in: Kitchen, Living & Working

With the growing trend in business that encourages employees to work from home, more and more manufacturers are providing home office furnishings that are compact and incorporate integral storage. Often with home offices, spaces are shared with other functions, including living rooms, bedrooms, and dens, necessitating compact furnishings, including desks that fold up to look like cabinets.

### Potential Issues:

Try to choose office furniture with low-formaldehyde offgassing.

### Related Strategies:

IDP10

### References/Resources:

*Sustainable Residential Interiors*, Foster/Stelmack/Hindman – Associates III

“Taking a Green Approach to Furniture”

[www.bayarea.greenhomeguide.com/index.php/knowhow/entry/943/C221](http://www.bayarea.greenhomeguide.com/index.php/knowhow/entry/943/C221)

## 147. Select solid furniture that is made from green and safe sources

### Strategy included in: Kitchen, Bedroom, Living & Working

With all furniture, but especially in the bedroom, select furniture that will not emit significant sources of formaldehyde. Furniture made with conventional particleboard or medium-density fiberboard (MDF) that is produced with urea-formaldehyde (UF0 binders should be avoided. More preferable is furniture made from solid wood or from manufactured wood products with soy-based, phenolic, or polyurethane (MDI) binders. Also look for furniture finished with zero- or low-VOC coatings and made with FSC-certified wood and other green materials.

### Potential Issues:

With furniture made from salvaged wood, testing for residual lead paint is recommended.

### Related Strategies:

IEQ159

### References/Resources:

*Sustainable Residential Interiors*, Foster/Stelmack/Hindman – Associates III

“Taking a Green Approach to Furniture”

[www.bayarea.greenhomeguide.com/index.php/knowhow/entry/943/C221](http://www.bayarea.greenhomeguide.com/index.php/knowhow/entry/943/C221)

## 148. Select cabinets made from greener materials

### Strategy included in: Kitchen

A number of stock and semi-custom cabinet manufacturers will let you select cabinets that are from some FSC-wood (solid or veneers) and have low toxic finishes. In addition, the boxes of the cabinets can be made from marine grade plywood (not particle board or interior-grade ply), which will emit lower formaldehyde levels.

Totally custom cabinetry provides the opportunity to select all FSC-wood, potentially all solid wood boxes and drawer faces and doors, with any degree of ‘green-ness’ for cabinets’ paint or finish.

The trend to add real “furniture” pieces to the kitchen or bathroom provides an opportunity to select furniture, antiques or unique reclaimed pieces into the design. Certain design styles are easy to keep clean, both by the nature of the style and the materials used to make them. Strive for cabinets that can be cleaned using the least toxic products.

### Potential Issues:

Currently, in order to secure greener materials for cabinetry, custom or semi-custom cabinet manufacturers must be used, which usually reflects higher price point.

## Related Strategies:

MR118

## References/Resources:

*Good Green Kitchens*, Jennifer Roberts, Publisher: Gibbs Smith, 2006

“Where Can I Find Wheatboard Unfinished Cabinets?”  
[www.bayarea.greenhomeguide.com/index.php/knowhow/entry/1311/C221](http://www.bayarea.greenhomeguide.com/index.php/knowhow/entry/1311/C221)

## 149. Install environmentally preferable countertops

### Strategy included in: Kitchen, Bathroom

Countertops function as horizontal surfaces to prepare food and perform other kitchen related activities. One should examine the relevance of using products with a higher environmental toll, such as exotic granite, or those typically considered not very green, such as plastic laminate. Greener choices would include natural stone, tiles, manufactured solid surfaces (some with recycled content), and wood and plastic laminates with greener substrates. The durability and cleanability of the countertop is an important consideration.

The substrates that support the finished countertop should be constructed from green materials as well, such as an exterior grade plywood, preferably from a certified wood source. When using substrates with any unsafe degree of chemical emissions, seal penetrations and exposed surfaces with numerous coats of appropriate sealer or paint to block some of those emissions.

### Potential Issues:

It is difficult to find green countertops at the lower end of the price range, and it is very difficult to change the market trend that reveres granite that is often Italian and far from local.

## Related Strategies:

IDP1

## References/Resources:

“Green Countertop Know-How”  
[www.greenhomeguide.com/index.php/knowhow/](http://www.greenhomeguide.com/index.php/knowhow/)

## 150. Select furniture from suppliers that are practicing fair and safe manufacturing processes

### Strategy included in: Bedroom, Living & Working

As the majority of our furniture and accessories manufacturing continues to be produced outside of the U.S. and Canada, we are more and more separated from the source of these goods. Finding accurate and honest information about manufacturing processes, and factory worker safety and well-being, is challenging in our growing global market. For example, some of the finishes

that are safest for homeowners, such as manufactured wood products made with polyurethane (MDI) binders, pose significant risk to factory workers (MDI is highly toxic until fully cured). Try to purchase from local or U.S. companies with environmentally and socially responsible business practices.

### Potential Issues:

It is often difficult to be sure that a “U.S.-made” product is derived from U.S.-made components. For example, some particleboard and medium-density fiberboard (MDF) used in furniture making is foreign-made and significantly exceeds acceptable formaldehyde standards in the U.S.

## Related Strategies:

MR147

## References/Resources:

Sustainable Furniture Council -  
[www.sustainablefurniturecouncil.org](http://www.sustainablefurniturecouncil.org)

## 151. Select upholstered furniture with care

### Strategy included in: Bedroom, Living & Working

Upholstered furniture is made up of an assembly of many different parts. From the hardwood framing and glues, to the supporting parts such as webbing and springs, to the foams, cushioning and fabrics—each of these components can have health and environmental implications.

- Framing should be made from hardwoods, glued or attached with water-based glues. Framing is available from wood that is certified or from well-managed (FSC-certified) forests.
- Webbing is usually made from jute and springs are made from steel. Ask the supplier or furniture manufacturer about the source of these materials.
- Foams used for upholstered goods are typically made from synthetic materials that used to contain potentially harmful brominated flame retardants (BFRs). The BFR of greatest concern, pentaBDE, was phased out in 2005, and today upholstered furniture and bedding manufacturers are using fire barrier layers to achieve fire resistance. Salvaged upholstered furniture and mattresses will likely contain BFRs in the polyurethane foam. When BFRs are present, they may volatilize or be released as dust as the foam breaks down over time. One solution with upholstered furnishings is to use products made with organic or “Pure Grow” wool, which is naturally flame resistant.

### Potential Issues:

It is very difficult to get information on flame retardants used in furniture, especially since the fire resistance strategies have changed considerably in recent years; look



for companies that have pledged to eliminate BFRs or halogenated flame retardants across their product lines.

**Related Strategies:**

MR118, IEQ189

**References/Resources:**

“Furniture, Mattresses, and Flame Retardants”  
[www.thegreenguide.com/docprint.mhtml?i=106&s=pbde](http://www.thegreenguide.com/docprint.mhtml?i=106&s=pbde)  
*Sustainable Residential Interiors*, Foster/Stelmack/Hindman – Associates III

## 152. Choose environmentally preferable fabrics

**Strategy included in: Bedroom, Living & Working**

Choices in more environmentally-friendly fabrics have grown dramatically over the past half dozen years. Improvements in sources for raw materials, as well as better manufacturing processes, has provided designers with many durable and attractive fabrics in both natural and synthetic goods. Best choices include fabrics with no residual chemicals or heavy metals, fabrics made from organically grown, rapidly-renewable resources such as cotton, hemp, wool, and wool-blends. Greener synthetic fabrics include those made with recycled plastic content. Look for fabric made by companies that oversee their overseas manufacturing.

**Potential Issues:**

Although many greener and more attractive textiles are becoming available, we still need to look at all the component parts of the fabric, such as the growing needs of any plant materials used, manufacturing processes and locations, and the fabrics' carbon footprint. Recycled polyester fabrics must be low in, or free of, antimony.

**Related Strategies:**

IDP6, IEQ189

**References/Resources:**

“Eco-Tip: Mini-Directory of Green Fabrics”  
[www.treehugger.com/files/2007/02/ecotip\\_mini\\_dir.php](http://www.treehugger.com/files/2007/02/ecotip_mini_dir.php)

## 153. Support local artisans as well as indigenous peoples

**Strategy included in: Bedroom, Living & Working**

Support sustainability by purchasing art, home decorations, and accessories from local artists and crafts people, and from indigenous peoples who maintain sustainable lifestyles and protect their ecosystems through the production of traditional crafts. With the use of locally produced goods, not only are local economies supported, but the added environmental impacts of shipping items from remote locations are avoided.

**Potential Issues:**

Most products supporting talented and poorer indigenous peoples must be shipped long distances.

**Related Strategies:**

IDP6

**References/Resources:**

*Sustainable Residential Interiors*, Foster/Stelmack/Hindman – Associates III  
[www.tenthousandvillages.com](http://www.tenthousandvillages.com)

## 154. Choose environmentally friendly outdoor furniture and accessories

**Strategy included in: Outdoor Living**

Outdoor furniture is a challenge because the weather can quickly degrade many materials. The majority of outdoor furniture sold today is made from virgin plastic, including PVC (vinyl). Plastic furniture is resistant to moisture, but degrades in sunlight, significantly reducing the expected life. Greener options include FSC-certified wood furniture, and furnishings made from wood and recycled high-density polyethylene (HDPE) composite material.

With the growing popularity of outdoor cooking, look for durable products that are designed to withstand the elements, including stainless steel grills and terra cotta fire pots.

**Potential Issues:**

Durability is key with outdoor furnishings, and care is an important factor. Outdoor furniture should be stored under cover during months when it will not be used.

**Related Strategies:**

IDP1, MR109

**References/Resources:**

*Sustainable Residential Interiors*, Foster/Stelmack/Hindman – Associates III

## Use

### 155. Provide for paper recycling

**Strategy included in: Living & Working**

In a home office or other space in the home where mail is sorted or wastepaper generated, provide a paper recycling receptacle. Additional storage may be required for paper recycling in a garage or utility room, especially in homes with newspaper subscriptions that generate considerable paper waste.

**Potential Issues:**

Check with the municipal solid waste authority to find out what forms of paper are accepted for recycling. Some areas may not accept boxboard, for example, or may require that corrugated cardboard be separated out.

**Related Strategies:**  
IDP12

**References/Resources:**

“Setting Up A Home Office: Making Environmental Choices”  
[www.epa.gov/epaoswer/aging/home-off.pdf](http://www.epa.gov/epaoswer/aging/home-off.pdf)

## 156. Select materials that are easy to clean

**Strategy included in: Kitchen, Bathroom**

Some interior finish materials inherently need stronger chemicals to keep them safe and clean. Choosing solid surfaces that do not need regular applications of treatments and sealers will reduce the use of unsafe chemicals.

**Potential Issues:**

Color can play an important role in the maintenance and service life of finish materials, particularly of fabrics.

**Related Strategies:**  
IEQ196

**References/Resources:**

“Good, Clean Fun: How to clean your house without hurting the planet”  
[www.grist.org/advice/possessions/2003/03/18/possessions-cleaning/index.html](http://www.grist.org/advice/possessions/2003/03/18/possessions-cleaning/index.html)

Unified Green Cleaning Alliance -  
[www.zerowaste.org/ugca.htm](http://www.zerowaste.org/ugca.htm)

## 157. Consider using bulk-product dispensers for body care products

**Strategy included in: Bathroom**

Bulk dispensers allow for the purchase of body care products that are bought in bulk, reusing one’s own plastic containers, and reducing the number of plastic bottles thrown away. Due to the target market for body care products available in bulk—usually available at health food stores and co-ops—most of these products are made from healthier ingredients by companies that have progressive policies, including cruelty-free product testing.

**Potential Issues:**

Bigger storage containers for body products require more storage space, which can be in tight supply with a small bathroom. Investigate nearby or adjacent storage to substitute for bathroom storage of bulk containers.

**Related Strategies:**  
IDP10

**References/Resources:**

*Sustainable Residential Interiors*, Foster/Stelmack/Hindman – Associates III

# Indoor Environmental Quality (IEQ)

## General Design and Construction Strategies

### 158. Control the spread of pollutants

**Strategy included in: All Projects**

During any remodeling project or the construction of an addition, particularly when the house is being lived in while construction is going on, it is very important to keep contaminants from the construction site out of the house. Many construction activities, such as concrete grinding, tile and backerboard cutting, pipefitting, drywall finishing, caulking and foam sealing, gluing, and painting can introduce significant quantities of indoor air contaminants. To control such contaminants, first avoid creating them to the extent possible by using zero-VOC paints and finishes, carrying out dust-producing activities outside of the space if possible, and capturing pollutants as they are produced (with sanding and drywall finishing, for example). Second, seal off the construction area from the rest of the living space by erecting tightly sealing temporary partitions. Third, operate temporary exhaust fans in the area under construction to maintain negative pressure and keep airborne contaminants from flowing into adjacent interior spaces—alternately, the adjacent living space can be pressurized. And fourth, seal off ducts, air distribution registers, and air inlets for ventilation systems to avoid contaminating ducts and HVAC equipment.

**Potential Issues:**

In general, indoor contaminants will be far worse from demolition of existing space than from new construction activities. Be particularly careful in isolating all demolition activities from the rest of the house. When you use an exhaust fan to depressurize a space, make sure that this negative pressure does not affect the function of whatever gas appliances may be in the space or adjacent to it.

**Related Strategies:**  
IDP5

**References/Resources:**

“Indoor Environmental Quality During Construction Projects”  
[www.ehs.uci.edu/programs/ih/IEQinConstruction.html](http://www.ehs.uci.edu/programs/ih/IEQinConstruction.html)

“Addressing Indoor Environmental Concerns During Remodeling”  
[www.epa.gov/iedweb00/homes/hip-concerns.html](http://www.epa.gov/iedweb00/homes/hip-concerns.html)

## 159. Test for, and appropriately handle, hazardous materials

### Strategy included in: Kitchen, Basement, Home Performance, Gut Rehab

While some hazardous materials are fairly apparent, such as mold and asbestos, it is usually a good idea to test for potential hazards in an older home. Hazards such as lead paint and persistent pesticides generally cannot be identified without testing, and even visible hazards like mold and asbestos may be hard to identify. Various test kits are available to aid in identification of these hazards.

How to deal with hazards that are found depends on the material. Wood trim painted with lead paint can be removed and disposed of, stripped and sealed off-site, or painted with a specialized “lead-encapsulant” coating. Asbestos should be encapsulated or removed by a trained asbestos mitigation contractor. Wood contaminated with persistent pesticides, such as chlordane, should be removed and disposed of at a hazardous waste landfill. Mold should be cleaned up by someone trained in mold mitigation, or mold-contaminated materials should be removed and disposed of. Whenever salvaged materials are used in a remodeling project, they should be tested for lead paint before installation and either avoided or stripped and sealed.

#### Potential Issues:

If not properly dealt with, problems with hazardous materials can be exacerbated by releasing contaminants into the house. Be aware of potential liability exposure when dealing with such hazards such as asbestos, lead paint, and mold.

#### Related Strategies:

IDP5, IEQ160

#### References/Resources:

“Hidden Environmental Hazards for the Home Remodeler”  
[www.montana.edu/wwwcxair/remodel.htm](http://www.montana.edu/wwwcxair/remodel.htm)

“Playing it safe: How to keep your family out of danger during a remodel”  
[www.consumerreports.org](http://www.consumerreports.org)

## 160. Conduct lead-safe work

### Strategy included in: Home Performance, Gut Rehab

Many older existing homes still have lead-based paint that can pose a hazard for workers and the occupants of the home. Lead-safe work practices should be followed during any remodeling work, including weatherization projects.

#### Potential Issues:

Follow local regulations for worker protection, risk mitigation and homeowner notification for any work that could or does involve lead-based paint.

#### Related Strategies:

IDP5, IEQ159

#### References/Resources:

Weatherization Assistance Program - [www.waptac.org/](http://www.waptac.org/)

## 161. Install track-off mats at exterior doors

### Strategy included in: Kitchen, Major Addition, Gut Rehab, Deep Energy Retrofit

Area rug and track-off mats at doorways are an excellent way to control dirt and pollutants from coming into the home through major entryways. Entryways should be designed to provide adequate space for track-off mats so that people and pets entering scuff their feet several times.

#### Potential Issues:

Track-off mats are designed to get wet, so provision should be made for that. The surface beneath the mats should be impermeable and easily washable (such as concrete, stone, or tile), and the mat should be easily removable for cleaning.

#### Related Strategies:

IDP5, IDP9

#### References/Resources:

“The Sensible House Project: Contaminants”  
[www.sensiblehouse.org/tu\\_hlth\\_toxics.shtml](http://www.sensiblehouse.org/tu_hlth_toxics.shtml)

## 162. Clean-up and dispose of pressure treated sawdust and shavings appropriately

### Strategy included in: Outdoor Living

Sawdust from all but sodium silicate pressure-treated lumber is potentially hazardous and should be collected during construction and properly disposed of. Collect sawdust and shavings and dispose of through landfiling. Never burn scraps.

#### Potential Issues:

Working outdoors, it may be difficult to collect sawdust. When working on a deck, spread a drop cloth beneath to capture sawdust.

#### Related Strategies:

MR107

#### References/Resources:

“Lumber Pressure Treated With CCA”  
[www.dec.ny.gov/chemical/8790.html#epaalt\\_](http://www.dec.ny.gov/chemical/8790.html#epaalt_)

## Foundation

## 163. Install a radon mitigation system

### Strategy included in: Major Addition, Basement

Radon is a radioactive element that can enter a house through a concrete slab floor or foundation walls; it is

considered the number two source of lung cancer in the U.S., after cigarettes. Radon is not the only soil gas of concern; other potentially hazardous soil gases include pesticide residues, hydrocarbons and other contaminants in the soil from past spills. A well-designed radon mitigation system includes a four-inch layer of crushed stone beneath a floor slab with a four-inch standpipe that extends through the slab into the layer of crushed stone. This standpipe is typically installed to have a straight shot from slab to roof so that the stack effect passively pulls gases from beneath the slab. Should radon testing ever show high radon levels in the house, an in-line fan can be added to the pipe to actively depressurize the sub-slab area.

**Potential Issues:**

If not properly sealed, the standpipe extending through the concrete slab can be a source of moisture or termites.

**Image: Air-Tight Sump with Radon Exhaust System**



**Related Strategies:**

IDP5, IDP19

**References/Resources:**

EPA - [www.epa.gov/radon/index.html](http://www.epa.gov/radon/index.html)

## 164. Install CO and smoke alarms

**Strategy included in: Home Performance, Major Addition, Gut Rehab, Deep Energy Retrofit**

Although many local building codes require the installation of smoke alarms during home renovation projects, it should also be done in coordination with carbon monoxide (CO) detectors in homes with any type of combustion equipment, unvented space heaters, or where backdrafting is a potential CO hazard, such as in a house with a fireplace, woodstove, or atmospherically-vented water heater, boiler or furnace.

**Potential Issues:**

The type of CO monitor is important, as well as the installation location; follow manufacturer restrictions on CO monitor location.

**Related Strategies:**

EA104

**References/Resources:**

“Basic Information: Carbon Monoxide”  
[www.epa.gov/iaq/co.html](http://www.epa.gov/iaq/co.html)

## Building Envelope

### 165. Isolate attached garages

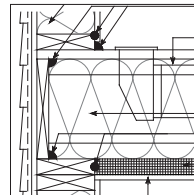
**Strategy included in: Kitchen, Bedroom**

It is quite common for rooms adjacent to attached garages (most commonly the kitchen and/or the “bonus” room—be it a bedroom, family room, or playroom) to have poor insulating and air sealing details between the attached garage and these adjacent living spaces. For health/safety and energy efficiency reasons, it is imperative that the air and thermal barriers be complete and continuous between these two spaces and/or that the garage space be depressurized with a high-efficiency exhaust fan.

**Potential Issues:**

The garage ceiling and interior wall(s) will already have gypsum board sheathing per the building code, requiring its removal to re-insulate and airseal the shared framing assemblies between the garage and bonus room and/or the garage and kitchen. It is quite possible that thermal comfort or odor problems from the garage are enough to indicate a need to address this issue but a blower door test will certainly confirm the need.

**Detail: Air Sealing at Garage Ceiling**



**Related Strategies:**

IDP5, EA54

**References/Resources:**

“EPA Energy Star Thermal Bypass Checklist”  
[www.energystar.gov/](http://www.energystar.gov/)

“6 Steps to a Healthier Garage”  
[www.offroaders.com/tech/healthier-garage.htm](http://www.offroaders.com/tech/healthier-garage.htm)

## HVAC

### 166. Install effective kitchen ventilation

**Strategy included in: Kitchen**

A kitchen range hood fan exhausted to the outdoors is a combustion safety requirement when gas kitchen appliances are installed and is an odor and moisture control strategy for both gas and electric stoves/ovens. The fan should be, at a minimum, Energy Star-rated, which ensures an efficacy of at least 2.8 cfm/watt, a maximum sound level of 2.0 sones, and fluorescent lighting for products with integral lights. Quiet fans are important because homeowners are unlikely to use noisy fans.



It may also make sense to provide whole-house ventilation with an exhaust port in the kitchen. The best whole-house ventilation systems are balanced (two fans with roughly equal incoming and outgoing air flow), and in cold climates it makes sense to provide heat recovery to capture heat from the outgoing air flow.

#### **Potential Issues:**

The negative pressure exerted by some powerful range hoods can be problematic when combined with operation of other equipment, such as clothes dryers, and fireplaces or wood stoves. A worst-case depressurization test can be helpful in identifying this problem and one important solution is to make sure that all major combustion equipment is sealed combustion or power-vented.

#### **Related Strategies:**

IDP2, IDP4, IEQ171

#### **References/Resources:**

Home Ventilating Institute Library - [www.hvi.org/resource/library/library.html](http://www.hvi.org/resource/library/library.html)

“Oversized Kitchen Fans—An Exhausting Problem” [www.homeenergy.org/archive/hem.dis.anl.gov/eehem/99/990113.html](http://www.homeenergy.org/archive/hem.dis.anl.gov/eehem/99/990113.html)

### **167. Install effective bath ventilation**

#### **Strategy included in: Bathroom**

Because so much moisture is produced in a bathroom, ventilation is extremely important. A bath fan should vent to the outdoors, rather than attic, keeping any duct runs as short as possible with few sharp bends (to minimize pressure drop and loss of effectiveness). Specify a durable fan rated for *continuous operation*, even though the cost will be higher than the least expensive bath fans available. An energy-efficient fan motor will save energy and money, particularly if the fan will serve whole-house ventilation needs. Size the fan according to the ventilation needs it will be satisfying and the pressure-drop from the ducting; most bath fans should provide 50–75 cubic feet per minute (cfm). The fan should also be as quiet as possible; a maximum of 1.5 sones is recommended, and below 1.0 sones is preferable. Ducting should be installed to minimize vibration and noise. The most common control for a bath fan is a simple on-off switch next to the light switch; more sophisticated controls provide for automatic operation based on humidity level, automatic shut-off a certain period of time after the lights are turned off, or automatic operation throughout the day—either continuous or intermittent. The latter control option is called for if bathroom fans are being relied upon to satisfy the home’s whole-house ventilation needs.

#### **Potential Issues:**

The key to bath exhaust fans is getting people to use them. They must be quiet and often hard-wired to the

light and/or on a mandatory timing cycle.

#### **Related Strategies:**

IDP2, IDP4, IEQ171

#### **References/Resources:**

“EPA Energy Star Ventilating Fans” [www.energystar.gov/](http://www.energystar.gov/)

Home Ventilating Institute - [www.hvi.org](http://www.hvi.org)

### **168. Provide appropriate venting of all combustion-based heating and water heating equipment**

#### **Strategy included in: Gut Rehab, Deep Energy Retrofit**

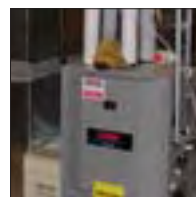
Improperly vented or unvented combustion equipment can introduce combustion gases into a house through backdrafting. Backdrafting most commonly occurs with gas- or oil-fired heating equipment that relies of “natural draft” for venting the combustion products up a chimney. (Natural draft venting is the process by which lightweight flue gasses naturally rise up a chimney due to their buoyancy.) To prevent backdrafting, only *sealed-combustion* or *power-vented* combustion equipment should be installed. Most of the high-efficiency furnaces, boilers, and water heaters sold today already incorporate power venting or sealed-combustion, but many older models do not. Install a carbon monoxide detector whenever combustion heating and water heating equipment is installed to warn occupants of combustion gas spillage or malfunctioning power-venting fans.

Unvented combustion heating equipment, such as vent-free gas stoves and gas fireplaces, should never be installed in any house—especially an energy-efficient, tight house. In addition to introducing small quantities of carbon monoxide and other combustion byproducts, unvented combustion devices introduce significant quantities of water vapor, which can cause moisture problems.

#### **Potential Issues:**

Particularly in tight homes, kitchen range-hood fans (especially downdraft and commercial-style top-venting models), outdoor-venting central vacuum cleaning systems, and wood stoves and fireplaces, can depressurize a house, and exacerbate backdrafting. Conduct a worst-case depressurization test as cited below.

#### **Image: Sealed Combustion, Condensing Efficiency Gas Furnace**



**Related Strategies:**

IDP2, IEQ166

**References/Resources:**

“Backdrafting: Causes and Cures”

[www.homeenergy.org/archive/hem.dis.anl.gov/eehem/91/910512.html](http://www.homeenergy.org/archive/hem.dis.anl.gov/eehem/91/910512.html)

“Combustion Safety Test Procedure for Vented Appliances”

[www.bpi.org/documents/gold\\_sheet.pdf](http://www.bpi.org/documents/gold_sheet.pdf)**169. Consider stand-alone equipment to address moisture****Strategy included in: Basement, Living & Working**

If moisture problems are limited to only one area of the house, such as a basement or home office, consider a stand-alone dehumidifier. Dehumidifiers are rated by moisture removal capacity and include either integral receptacles to collect water (which have to be regularly emptied) or a drain line that can lead to a floor drain or outdoors.

**Potential Issues:**

Dehumidification is most effectively accomplished with whole-house air distribution systems.

**Related Strategies:**

IDP19, IDP24, IEQ173

**References/Resources:**EPA Energy Star Dehumidifiers - [www.energystar.gov/](http://www.energystar.gov/)**170. Provide for forced-air system pressure relief****Strategy included in: Bedroom**

There are basically five ways to address pressure relief in homes with forced-air HVAC systems when the doors to rooms are closed: dedicated return ducts, operable interior transoms, jump ducts, transfer grilles, or undercutting doors (at least 1.5 inches).

**Potential Issues:**

Negative pressure in a bedroom may be evidence of an improperly balanced forced-air distribution system. Carry out a room-to-room pressurization test to determine the extent of the problems.

**Related Strategies:**

IDP5, EA52, IEQ168

**References/Resources:**

“Transfer Grilles”

[www.buildingscienceconsulting.com/resources/mechanical/](http://www.buildingscienceconsulting.com/resources/mechanical/)

“Pressure Relief: The Hows and Whys”

[www.advancedenergy.org/buildings/svenews/index.html#pressure](http://www.advancedenergy.org/buildings/svenews/index.html#pressure)

“Minimizing Energy Losses In Ducts”

[www.eere.energy.gov/consumer/your\\_home/](http://www.eere.energy.gov/consumer/your_home/)**171. Provide fresh air as part of ventilation system****Strategy included in: Bedroom**

In tight houses, mechanical ventilation is extremely important. In fact, most experts now recommend that nearly all houses should have mechanical ventilation. Relying on natural ventilation through operable windows may be fine if there is an adequate pressure differential between indoors and out (for example, a breeze or significant difference in temperature), but during the spring and fall swing seasons, open windows may not provide adequate ventilation. Also, for those with pollen allergies, or who live in smoggy/urban environments, keeping windows open at all may not be practical. Rely on fresh air either supplied directly to the living areas in a dedicated ventilation system, or delivered through the distribution ducts of an HVAC system. With a balanced whole-house ventilation system (in which two fans are used—one to exhaust stale indoor air and another to deliver fresh outdoor air), fresh air should be delivered to locations in the house where homeowners will spend the most time, such as bedrooms and living rooms, and exhaust air should be removed from locations where moisture or pollutants are generated, such as kitchens, bathrooms, and hobby rooms. In cold climates, energy performance of a balanced ventilation system can be improved by using heat-recovery ventilator (HRV) that recovers heat from the outgoing air stream and transfers it to the incoming fresh air. If an exhaust-only ventilation system is being used (in which fans exhaust air and make-up fresh air is provided naturally), passive inlet ports should be provided in bedrooms and other living areas. Advanced controls are available for mechanical ventilation systems to operate them continually, intermittently, or based on conditions in the home (such as humidity or carbon dioxide levels).

**Potential Issues:**

Properly balancing ventilation systems is important. Improper balancing or use of exhaust-only ventilation without fresh-air make-up ports, may depressurize the house and draw in radon and other soil gases. Remodelers should consider the use of the new ASHRAE 62.2 Ventilation standard in their high performance remodeling work.

**Related Strategies:**

IDP5, EA69

**References/Resources:**

“Read This Before You Ventilate”

[www.buildingscienceconsulting.com/resources/mold/](http://www.buildingscienceconsulting.com/resources/mold/)**ASHRAE Standard 62.2: Ventilation and Acceptable Indoor Air Quality in Low-Rise Residential Buildings**, ASHRAE

## 172. Provide for additional ventilation and air conditioning needs in certain activity areas

### Strategy included in: Living & Working, Outdoor Living

Home offices with copiers and laser printers, hobby rooms where paints or adhesives are used, and garages or storage areas where vehicles or hazardous substances are stored all may require higher ventilation rates than other areas in a home. Home offices with significant equipment may generate enough extra heat that more air conditioning is required. Work with a mechanical engineer to determine these additional ventilation and cooling loads. With whole-house ventilation systems, provide for operation at a higher airflow rate in locations where significant pollutants are generated. If a whole-house ventilation system is not being installed, provide separate exhaust fans in these locations, with passive make-up air vents.

### Potential Issues:

Whenever extra exhaust ventilation is added to a home, install no more cfm capacity than is required to manage the extra contaminant load the activity represents. And whenever exhaust ventilation is added, a whole-house depressurization test should be conducted to determine what happens to any gas appliances or to radon entry into the home as a consequence of every exhaust component in the home operating all at the same time.

### Related Strategies:

IDP5

### References/Resources:

"Ventilation and Air Quality in Offices"  
[www.epa.gov/iaq/pubs/ventilat.html](http://www.epa.gov/iaq/pubs/ventilat.html)

**ASHRAE Standard 62.2: Ventilation and Acceptable Indoor Air Quality in Low-Rise Residential Buildings**, ASHRAE

## 173. Provide for additional air filtration

### Strategy included in: Bedroom

In general, whole-house filtration systems, integrated with air-handling equipment, are more effective than stand-alone room units. Providing stand-alone, room-sized air filtering equipment might be advised, however, if the house HVAC system does not provide the needed filtration in certain rooms, such as bedrooms. Room air cleaners that use fans to push air through filters or electrostatic precipitators are far more effective than units without fans; avoid the latter. Size air filtering equipment to room air volume and choose a unit that removes pollutants with activated carbon, and good HEPA filtration. Choose the most energy-efficient unit available.

### Potential Issues:

Never install air cleaners that generate ozone, which is a dangerous pollutant. Some disreputable companies

continue to market ozone generators for standard household use.

Care must be taken in adding higher efficiency air filters to central forced-air systems; make sure that the added pressure drop associated with installation of the air filter can be met by the existing air handler motor or the air handler motor is upgraded to deal with the increased pressure drop.

### Related Strategies:

IDP5, IEQ169

### References/Resources:

"Guide to Air Cleaners in the Home"  
[www.epa.gov/iaq/pubs/airclean.html](http://www.epa.gov/iaq/pubs/airclean.html)

"High-Efficiency Whole-House Air Filtration"  
[www.toolbase.org](http://www.toolbase.org)

## 174. Install appropriate HVAC in the finished basement

### Strategy included in: Basement

Many basements need active ventilation and dehumidification much more than they need active space cooling and heating. Make sure that finished basement spaces have both carbon monoxide (CO) monitors and humidistats along with conventional thermostats. If a stand-alone dehumidifier is used, it should be Energy Star-rated. (Note that dehumidifiers with scroll wheels move air around more efficiently than those with paddle fans.)

### Potential Issues:

Be careful about relying upon your space cooling system to dehumidify, particularly in basement spaces. Check the Sensible Heat Ratio (SHR) of the existing or new air conditioning system and where high humidity is a problem, make sure that the SHR is .75 or less. Seek the advice of a qualified mechanical engineer if uncertain about moisture dynamics of mechanical equipment.

### Related Strategies:

IDP5, EA63, IEQ169

### References/Resources:

Energy Star -  
[www.energystar.gov/index.cfm?c=dehumid.pr\\_dehumidifiers](http://www.energystar.gov/index.cfm?c=dehumid.pr_dehumidifiers)  
[www.energystar.gov/index.cfm?c=vent\\_fans.pr\\_vent\\_fans](http://www.energystar.gov/index.cfm?c=vent_fans.pr_vent_fans)

## Plumbing

## 175. Install undersink water filtration system

### Strategy included in: Kitchen

Undersink water filters remove contaminants from tap water and improve the taste, thus reducing the likelihood that homeowners will feel a need to buy bottled water (which results in significant packaging waste). There are a number of options for water treatment, including

reverse-osmosis and ultraviolet (UV) treatment, but most common and least expensive are activated carbon or specialized-media filters installed under the kitchen sink with a special drinking-water faucet. With these filters, tap water is forced through filters that remove particles as well as a wide range of contaminants—depending on the media used. The filter cartridges are replaced as needed, typically after several months of use.

**Potential Issues:**

While undersink water filters rely on water pressure to operate—no energy use—waste is generated when filters are replaced, and wastewater may be generated with systems that involve backwashing of the filter. Before installing a water filter, consider lab testing of your water to determine whether there is justification for avoiding unfiltered tap water.

**Related Strategies:**

WE41

**References/Resources:**

“Consumer Guide to Water Filters”  
[www.nrdc.org/water/drinking/gfilters.asp](http://www.nrdc.org/water/drinking/gfilters.asp)

## 176. Install water filter on showerhead

**Strategy included in: Bathroom**

While some experts recommend whole-house water filters, it often makes more sense to limit filtration to the kitchen sink to filter drinking water [cross-link] and showerheads to filter the water homeowners use for showering. Screw-on showerhead water filters can remove chlorine from water-treatment chemicals and various compounds that may form when chlorine reacts with organic material in water, such as trihalomethanes, chloroform, and trichloroethylene. Showerhead filters typically rely on either charged copper- and zinc-based granules that remove chlorine by changing the free chlorine atoms into charged chlorine ions that are precipitated out (this is the principle of a KDF filter), or activated carbon filtration, or a combination of the two. The result is shower water from which most of the chlorine-based contaminants have been removed.

**Potential Issues:**

Most showerhead filters are screw-mounted and install on the shower step, above the showerhead. They can add several inches to the showerhead, necessitating mounting the showerhead higher in the shower stall. Showerhead filters have to be replaced regularly (typically every three to six months) to remain effective.

**Related Strategies:**

EA43

**References/Resources:**

Santa Barbara Green Remodeler Checklist -  
[www.greendifference.org/downloads/bgsb-remodel-list.pdf](http://www.greendifference.org/downloads/bgsb-remodel-list.pdf)

## Lighting and Electrical

### 177. Use prudent avoidance with electromagnetic fields

**Strategy included in: Bedroom**

There remains a great deal of uncertainty about health risks from electromagnetic fields (EMF), but there is enough evidence of risk to carry out *prudent avoidance* strategies to minimize homeowner exposure to these fields. This is particularly important in bedrooms, where people spend so much time. Use a gauss meter to test for magnetic fields, and carry out measures to minimize exposure to those fields. Common sources of high EMF include improper wiring of three-way switches (in violation to electrical code), which creates a current loop; old knob-and-tube wiring (which should be replaced for safety reasons as well); and accidental grounding of metal-sheathed (BX) electrical cable to grounded water pipes. Keep service panels away from heavily used interior spaces—especially bedrooms—and minimize high-current wiring runs along the most-used spaces.

It is also a good idea to keep electronic devices that generate significant magnetic fields (including some bedside clocks) at least several feet from beds.

**Potential Issues:**

Scientists are not in agreement about the level of risks from EMF fields.

**Related Strategies:**

IDP6, MR121

**References/Resources:**

“Exposure to Radio Frequency Electro-Magnetic Fields”  
[www.epa.gov/EPA-IMPACT/2003/September/Day-08/i22624.htm](http://www.epa.gov/EPA-IMPACT/2003/September/Day-08/i22624.htm)

“Electromagnetic Pollution”  
[www.buildingbiology.net/elpo.html](http://www.buildingbiology.net/elpo.html)

The Collaborative on Health and the Environment -  
[www.healthandenvironment.org](http://www.healthandenvironment.org)

### 178. Provide controllable interior shading

**Strategy included in: Living & Working**

Most rooms that are actively used during the daytime, such as home offices, should have controllable blinds or shades on windows to allow users to both block glare and control heat gain. While useful in most rooms, controllable shading is most important on east- and west-facing windows. Venetian blinds, which allow sunlight to be directed upwards while controlling direct glare, are an excellent choice relative to sun-control, while accordion-type blinds that fit into a track at the edges and create a layer of trapped air when lowered are significantly more effective at controlling heat loss.



**Potential Issues:**

Inward-opening casement (tilt-turn) windows generally cannot be fitted with interior blinds or shades. Assure that interior window treatments are not installed so that HVAC registers are blocked, that the positive air flows created by registers below windows are not negated or compromised, or that excess heat is not trapped behind close-fitting, inside mount window shades.

**Related Strategies:**

EA48, EA62, EA83

**References/Resources:**

“Window Orientation and Shading”

[www.fsec.ucf.edu/en/consumer/buildings/homes/windows/](http://www.fsec.ucf.edu/en/consumer/buildings/homes/windows/)

## Floor and Flooring Finishes

### 179. Avoid carpeting in high moisture areas

**Strategy included in: Kitchen, Bathroom**

Carpeting and soft porous floor coverings are an excellent choice to give comfort under foot, and to improve acoustical concerns. But in the best of situations, carpet is difficult to clean or dry out if it gets wet. Additionally, carpet is often installed over a carpet cushion that can break down and generate more dust—with older carpet cushion materials or materials made from recycled polyurethane, brominated flame retardants may be released into the space as the materials break down over time. In below-grade areas, or in rooms where water spills are inevitable, carpet should not be used. Even carpet products that are made exclusively of synthetic materials can harbor dust, dust mites and other materials that can be tracked into the house from outdoors.

**Potential Issues:**

Some areas with higher moisture potential are rooms where carpeting adds the benefits of warmth, cushioning, and sound control.

**Related Strategies:**

IDP4, IDP20, MR156, IEQ196

**References/Resources:**

*Sustainable Residential Interiors*, Foster/Stelmack/Hindman – Associates III

“House Dust Mites—OSU Extension Fact Sheet”

[www.ohioline.osu.edu/hyg-fact/2000/2157.html](http://www.ohioline.osu.edu/hyg-fact/2000/2157.html)

### 180. Choose hard-surface flooring

**Strategy included in: Kitchen, Bathroom, Basement**

Hard surface flooring includes finished concrete, tile, terrazzo, and resilient floor tiles (wood flooring is covered in another strategy). Concrete can provide a high-quality

finished floor in slab-on-grade applications. Using the concrete slab as the finished floor reduces material use. Concrete sealant and colorants can make any concrete floor an attractive and durable finished floor. New grinding and polishing equipment and sodium silicate densifying agents can be used to achieve very attractive, durable polished-concrete floors. Fly ash (or other pozzolanic material) content—a by-product from the production of electricity from coal-burning power plants—can be added to the concrete mix to reduce the amount of portland cement used, which is beneficial because standard portland cement is very energy-intensive to produce.

Tile and terrazzo flooring are durable, easy to maintain and healthy flooring choices. Care should be taken to use low-toxic glues, grouts, and grout sealers in their installation. A number of manufacturers are offering tile and terrazzo products with both pre- and post-consumer recycled content.

Hard surface floors may be preferable to carpeting in bedrooms because they are easy to keep clean, especially under the bed. Area rugs can provide cushioning underfoot and are removable for cleaning or drying if they get wet.

**Potential Issues:**

Concrete has high embodied energy, but using a concrete slab as a finished floor usually saves materials, because it obviates the need for a separate finished floor.

**Related Strategies:**

IDP5, MR114, IEQ191

**References/Resources:**

LEED for Homes program - [www.usgbc.org/ShowFile.aspx?DocumentID=2267](http://www.usgbc.org/ShowFile.aspx?DocumentID=2267) (Materials & Resources)

“Concrete Floor Finishes”

[www.toolbase.org](http://www.toolbase.org)

“Floor Score: What and Why”

[www.rfci.com/int\\_FloorScore.htm](http://www.rfci.com/int_FloorScore.htm)

### 181. Install appropriate finish flooring in basements

**Strategy included in: Basement**

The appropriate finish flooring for a basement depends in large part on the moisture profile of everything underneath it. If both liquid water and vapor have been decoupled from the basement floor system (comprehensive drainage system, capillary break, and vapor retarder or barrier—see Upgrade Basement Floor), then a wide range of finish flooring can be used. But if the basement floor system is relying upon drying to the interior to manage water vapor, then a vapor-permeable finish flooring must be used, and there are fewer choices; examples include finished concrete, concrete painted

with an appropriate acrylic-latex paint, and terra cotta tile pavers. Wall-to-wall carpeting is *not* recommended (even though it is highly vapor permeable), particularly if rigid insulation has not been installed as a part of the basement floor system (which would maintain a warmer floor surface where water would be unlikely to condense). If you don't know the vapor permeability of the finished flooring you are considering, and the distributor or the manufacturer doesn't have that information, do not use that finished flooring material.

#### **Potential Issues:**

Sound attenuation can be a significant concern in finished basements. If carpeting is part of this strategy, it should come in the form of throw rugs rather than permanently secured wall-to-wall carpeting, because the former can be easily removed for periodic cleaning and drying should they get wet. It is very important to couple this with control of interior relative humidity. (See the basement HVAC strategy.)

#### **Related Strategies:**

IDP25, IEQ179

#### **References/Resources:**

Basement Solutions of New England -  
[www.basementsolutionsne.com/delta\\_flooring.html](http://www.basementsolutionsne.com/delta_flooring.html)

DRICore Subfloor System -  
[www.dricore.com/en/eIndex.aspx](http://www.dricore.com/en/eIndex.aspx)

"Upgrading Below Grade"  
[www.pathnet.org/sp.asp?id=1800](http://www.pathnet.org/sp.asp?id=1800)

## **182. Use area rugs instead of wall-to-wall carpeting**

#### **Strategy included in: Bedroom**

Wall-to-wall carpeting and large carpets and their cushioning underneath, are very difficult to clean or remove for drying should they get wet. Because they harbor dirt, organic detritus, and moisture, they can become a significant source for mold and mildew. Hard-surface floors can be enhanced with smaller area rugs that can be removed for cleaning or drying. Try to avoid all biocide-treated (moth repellent) wool or cotton carpets.

#### **Potential Issues:**

This criterion may narrow the range of choices on furniture and fittings and add to cost.

#### **Related Strategies:**

IDP5, IEQ180

#### **References/Resources:**

*Sustainable Residential Interiors*, Foster/Stelmack/Hindman – Associates III

## **Wall and Ceiling Finishes**

## **183. Use non-paper-faced gypsum board in moist areas**

#### **Strategy included in: Bathroom, Basement**

A variety of interior wallboard products exist that will satisfy the building code in terms of smoke developed and combustibility, yet are also more moisture and mold resistant than conventional paper-faced drywall. These products are either monolithic (with cellulose fibers dispersed through the board), or faced with fiberglass rather than paper. Since most of these sheathings will still be porous in nature, they should be installed with a minimum 3/16-inch free space between the board margins and concrete. So-called moisture-resistant (MR) "greenboard" with wax emulsifiers, but still with paper facings, is not recommended

#### **Potential Issues:**

All of the non-paper faced alternative gypsum boards are more expensive than conventional paper-faced products.

#### **Related Strategies:**

IDP1, IDP24, MR126

#### **References/Resources:**

"Read This Before You Design, Build or Renovate"  
[www.buildingscienceconsulting.com/resources/foundations/](http://www.buildingscienceconsulting.com/resources/foundations/)

## **184. Limit use of wallcoverings in high moisture areas**

#### **Strategy included in: Kitchen, Bathroom**

To prevent mold and mildew, avoid the use of impermeable, surface-applied wallcoverings, such as vinyl (PVC) products in most applications. Vinyl wallcoverings can trap moisture in the wall surface or within the wall cavity. Permeable wall treatments, such as paints and clay surface treatments, or uncoated wallcoverings are recommended for these applications. The cleanability needs of a wall may pose a conflict in this regard; for maximum cleanability, an impermeable wallcovering might be desirable; the use of an impermeable layer on the interior of any building assembly means that this assembly **MUST** be capable of drying to the exterior—see the strategy on Vapor Profiles.

#### **Potential Issues:**

Design wall systems to minimize the transfer of moisture into the wall cavity while also providing breathability to allow wall cavities to dry out.

#### **Related Strategies:**

IDP25

#### **References/Resources:**

"Understanding Vapor Barriers"  
[www.buildingscience.com/doctypes/digest](http://www.buildingscience.com/doctypes/digest)

## 185. Use low- or zero-VOC interior paints and finishes

### Strategy included in: Kitchen, Bathroom, Bedroom

Paints, coatings and clear finishes can contain a wide range of hazardous chemicals, many referred to as volatile organic compounds (VOCs), which are detrimental to human health. Safer products are readily available through most major coating manufacturers. Although most include components that are derived from petroleum or natural gas, many are now waterborne (meaning that water, instead of solvent, is the carrier). These waterborne, acrylic products are strong and durable. Low- or zero-VOC products can be found in most tint bases to allow creation of nearly any color desired. Additionally, a few manufacturers are producing paints and coatings formulated for individuals with chemical sensitivities. (Some people are sensitive to the chemical compounds found in low- and zero-VOC paints and coatings.) While costing more, there are also “plant chemistry”-based paints and coatings that are formulated using (almost exclusively) plant oils and minerals. Natural clay and lime plasters provide another healthy alternative. Careful selection of safer paints and coatings is especially important in bedrooms, where people spend such long hours sleeping.

Recycled paint is also available for use as primer. These paints are produced from unused paint collected at solid-waste facilities. A number of brands are marketed widely.

### Potential Issues:

Low- and zero-VOC paints may still contain chemical compounds that could have adverse health effects for some individuals.

### Related Strategies:

IDP5, MR130

### References/Resources:

REGREEN Product Selection Resources - [www.regreenprogram.org](http://www.regreenprogram.org)

## 186. Limit use of VOC emitting wallcoverings

### Strategy included in: Bedroom

Plastic-coated-paper and vinyl wallcoverings are popular because they are very durable and easy-to-clean, but these PVC (vinyl) products contain high levels of phthalate plasticizers. Phthalates are endocrine disruptors (compounds that mimic natural hormones) that many experts consider to be health hazards. The PVC itself may be hazardous when its entire life cycle is considered. Finally, plastic wallcoverings block moisture, which can result in mold. Avoid these products, especially in bedrooms.

### Potential Issues:

Paper and natural-fiber wallcoverings are susceptible to moisture damage and mold (if they stay wet), and they cannot be washed as easily as vinyl or plasticized wallcoverings, so great care may be required in protecting these surfaces from soiling.

### Related Strategies:

IDP5, MR156

### References/Resources:

*Sustainable Residential Interiors*, Foster/Stelmack/Hindman – Associates III

## 187. Use low- or zero-VOC construction adhesives, caulking, and sealants

### Strategy included in: Kitchen, Basement

As with paints and coating products, there are many high-quality caulks and sealants for interior and exterior applications with very low VOC levels. Many major manufacturers are making these safer, and durable products readily available.

### Potential Issues:

Along with any health-related features like VOC levels, it is important to ensure that the selected product performs well for the particular application.

### Related Strategies:

IDP5, EA54

### References/Resources:

U.S. Green Building Council - [www.usgbc.org/ShowFile.aspx?DocumentID=2267](http://www.usgbc.org/ShowFile.aspx?DocumentID=2267) (Materials & Resources)

REGREEN Product Selection Resources - [www.regreenprogram.org](http://www.regreenprogram.org)

## Furniture and Fittings

## 188. Choose furniture and fittings that will not absorb moisture

### Strategy included in: Basement

Carpet, furniture made from standard particleboard and MDF, fully upholstered furniture, fabrics, and other porous products may absorb moisture, making them inappropriate choices for basement living spaces and other areas that may experience high humidity. Hard-surface flooring with smaller area rugs, solid wood furniture, loose cushion seating pieces, and solid-slat window shades would all be safer choices in these areas.

### Potential Issues:

This criterion may narrow the range of choices on furniture and fittings.

## Related Strategies:

IEQ191

## References/Resources:

*Sustainable Residential Interiors*, Foster/Stelmack/Hindman – Associates III

## 189. Choose furniture finished with least-toxic products

### Strategy included in: Bedroom, Basement

Other than plastic and plastic-laminated furniture products, most furniture is made from wood and is nearly always coated with some type of finish to protect its surfaces from wear and tear. The majority of these finishes are solvent-based synthetic stains and lacquers that can be both dangerous to workers during the manufacturing process and sources of VOC offgassing in homes until they completely cure (which can take months or years). Safer synthetic finishes are conversion varnishes and water-based urethane finishes. These products may still be unsafe in the factory, but can render a safer finish for the end-user.

Finishes made from natural ingredients, such as tung or linseed oil, are still solvent-based and contain volatile chemicals that chemically sensitive individuals may be sensitive to. From an ecological standpoint, these plant-based, more natural finishes are generally better than conventional products.

### Potential Issues:

From a health standpoint alone, the safest way to guarantee the “tolerability” of a finish is to order a finished sample, and have the homeowner self-test the product.

### Related Strategies:

MR152

### References/Resources:

*Sustainable Residential Interiors*, Foster/Stelmack/Hindman – Associates III

“Product Report: Wood Finishes”

[www.thegreenguide.com/reports/productprint.mhtml?id=24](http://www.thegreenguide.com/reports/productprint.mhtml?id=24)

## 190. Avoid fully upholstered furniture where moisture may be a problem

### Strategy included in: Bedroom, Living & Working, Basement

Upholstered furniture is made from porous and absorbent materials; once it absorbs and collects dirt and moisture, it does not readily release those agents. In areas where elevated levels of moisture are likely, one should limit the use of fully upholstered furniture. From a health standpoint, dust and dust mites will find a supportive environment in upholstered furniture, and thorough vacuuming and cleaning of upholstered

furniture is very difficult. Also, most fabrics are treated with potentially hazardous surface treatments to enhance their appearance, durability, and stain resistance.

A better choice is to use furniture made with finished wood framing, and unattached cushions that can be removed, cleaned and/or dried.

### Potential Issues:

This criterion may narrow the range of choices on furniture and fittings.

### Related Strategies:

IEQ191

### References/Resources:

*Sustainable Residential Interiors*, Foster/Stelmack/Hindman – Associates III

## 191. Minimize use of plush and porous materials

### Strategy included in: Bedroom, Office/living Space, Basement

Carpets, fabrics, and products with plush fibers and foam may absorb moisture, collect dirt, and act as sinks for other VOCs and airborne pollutants. Design and plan the use of these porous materials to allow for good cleaning and drying. In homes with extensive use of plush materials, extra care should be taken to manage moisture levels and avoid products that will offgas significant pollutants.

### Potential Issues:

This criterion may narrow the range of choices on furniture and fittings.

### Related Strategies:

IEQ190

### References/Resources:

*Sustainable Residential Interiors*, Foster/Stelmack/Hindman – Associates III

## 192. Select furniture that is easy to clean

### Strategy included in: Bedroom, Living & Working

When choosing all furniture and accessory items, consider how easy they will be to maintain, vacuum, and keep clean. Heavily detailed pieces, wicker and rattan, and upholstered pieces are generally not easy to keep clean. Smooth, hard-surfaced furniture is the easiest to maintain. In addition, some materials need ongoing applications of less-green cleaning products to keep them looking their best and ensure long lifetimes. Choose furniture and accessories that can be cleaned easily using environmentally responsible cleaning products and practices, and provide recommendations to homeowners



for sources of such cleaning compounds. Slipcovers over upholstered furniture allow removal and laundering, while protecting and prolonging the life of the primary upholstery. Avoid permanent-press and stain-resisting fabric treatments that may contain hazardous chemicals, such as formaldehyde and fluoropolymers (for example, Teflon).

**Potential Issues:**

This criterion may narrow the range of choices on furniture and fittings and add to cost.

**Related Strategies:**

IEQ196

**References/Resources:**

Destination Green - [www.destinationgreen.com](http://www.destinationgreen.com)

### 193. Select window treatments with health considerations in mind

**Strategy included in: Bedroom**

Window treatment in the form of shades and drapery have many benefits. They can insulate to reduce heat loss (especially with blinds that seal tightly into tracks at the edges), block unwanted solar heat gain and harmful UV rays, provide privacy, and enhance a room's appearance. But all porous materials and fabrics act as dust collectors, and can be difficult and time-consuming to take down and clean. Draperies may include linings that are made using potentially hazardous surface treatments. Almost all fabrics themselves contain dye residues, and are coated with surface treatments to enhance their resistance to fire and staining, improve appearance, modify the "hand" (how they hang), and boost durability. When possible, avoid complex fabric or foam window treatments made, or treated with, flame retardants, opting instead for smooth, nonporous surfaces such as shutters or untreated, non-vinyl shades.

**Potential Issues:**

The available options for insulating window treatments are less than they were in the 1980s; few such products are on the market.

**Related Strategies:**

EA62

**References/Resources:**

*Sustainable Residential Interiors*, Foster/Stelmack/Hindman – Associates III

"How Do I Select Safe Natural Fiber Products For My Home?"

[www.greenhomeguide.com/index.php/knowhow/](http://www.greenhomeguide.com/index.php/knowhow/)

### 194. Select mattress and bedding with attention to health issues

**Strategy included in: Bedroom**

The polyurethane foam used in mattresses used to contain brominated flame retardant chemicals (especially pentaBDE) in order to meet the federal flame-resistance standards, but today, most manufacturers achieve fire safety with fire barrier layers, rather than with BFRs. This is one reason to avoid salvaged mattresses and to look for mattresses manufactured after 2005, the year pentaBDE was phased out. Mattresses also are prone to trapping body moisture, which in combination with body heat and dead skin cells, may provide an ideal environment for dust mites and mold.

If produced correctly, environmentally responsible, chemical-free, organic fabrics, fills, and latex foam can provide natural resistance to dust mites, fire, moisture, and mold without harmful materials and chemicals. Chemical-free and/or organic wool padding is particularly suitable in mattresses for those with mold and dust mite allergies.

Bedding, which includes linens and pillows, can be manufactured from both natural and synthetic sources. Whenever possible, natural and—even better—organically grown plant-based products are good for our health and the environment. Organic-cotton sheets, and cotton, wool, or kapok pillows are readily available from a number of sources. Bamboo and Modal cellulose fiber sheets are increasingly popular, especially given their plant-fiber source, but the overseas manufacturing processes for these products are poorly understood and may pose significant health and environmental risks. Fiber made from bamboo or hemp may provide natural antimicrobial and antifungal benefits. Hemp is especially durable and long-lasting when uncompromised (by bleaching and other processes) in fiber manufacturing.

**Potential Issues:**

This criterion may narrow the range of choices on furniture and fittings and add to cost.

**Related Strategies:**

EA104, MR152

**References/Resources:**

International Sleep Products Association - [www.sleepproducts.org](http://www.sleepproducts.org)

### 195. Choose interior accessories with care

**Strategy included in: Bedroom, Living & Working**

It is difficult to find accessories—artwork, pictures, frames, silk flowers, and on and on—that are not made overseas where health and environmental standards may

be lax. It is often best to minimize all accessories both to avoid purchasing overseas goods with questionable health and environmental profiles, and to minimize cleaning and dusting. Buying older—rather than new—decorations is often a good option.

**Potential Issues:**

With antiques and older decorations, test for lead paint and try to avoid products with mold and mildew.

**Related Strategies:**

MR141, MR142, IEQ159

**References/Resources:**

*Sustainable Residential Interiors*, Foster/Stelmack/Hindman – Associates III

**Use**

**196. Use environmentally preferable cleaning materials and strategies**

**Strategy included in: Kitchen, Bathroom**

Many standard cleaning products contain and emit harmful chemicals and volatile organic compounds (VOCs). This can be especially dangerous due to the proximity to occupants and the frequency in which these products are used. Many nontoxic cleaning products are inexpensive and quite basic. Their use can improve indoor air quality.

**Potential Issues:**

This criterion may narrow the range of choices on furniture and fittings and add to cost.

**Related Strategies:**

EA104, EA105, MR156

**References/Resources:**

“Household Cleaners”  
[www.seventhgeneration.com/our\\_products/household.php](http://www.seventhgeneration.com/our_products/household.php)  
Family and Consumer Sciences -  
[www.ces.ncsu.edu/depts/fcs/index.html](http://www.ces.ncsu.edu/depts/fcs/index.html)

**197. Store all toxic chemicals away from living space**

All sorts of harmful chemicals can all escape from lawn-and-garden chemicals, lawnmower gas cans, partially used cans of paint, and so forth. Firesafe and carefully sealed storage units located in well-ventilated garages or storage sheds should be used for storage of such materials. Encourage homeowners not to keep older chemicals in their homes or garages; such materials can often be disposed of during hazardous-waste-collection at municipal solid waste facilities.

**Potential Issues:**

Some waterborne materials, such as latex paints, must be stored in locations where they won't freeze.

**Related Strategies:**

EA103, EA104

**References/Resources:**

[www.thegreenguide.com/green\\_home/](http://www.thegreenguide.com/green_home/)

**198. Be attentive to chemicals that might be stored in close proximity to a finished basement room**

**Strategy included in: Basement**

Potentially toxic chemicals, such as paints, solvents, and cleaning compounds, are often stored in the basement where homeowners won't think about them. When we create living spaces in basements, it is important to keep these chemicals and their emissions away from the living space, and not in proximity to the ductwork that will feed air to the basement room.

**Potential Issues:**

Hazardous chemicals should not be stored in living areas or basement spaces connected to living spaces, but if they must be stored in basements, at least keep them isolated from spaces that are to be remodeled.

**Related Strategies:**

EA103, EA104

**References/Resources:**

National Geographic - [www.thegreenguide.com/green\\_home/](http://www.thegreenguide.com/green_home/)

# Strategy Image Appendix

**IDP2 Home Performance Test During an Audit**



Photo: Matt Golden

**IDP2 Home Performance Test During an Audit**



Photo: Matt Golden

**IDP2 Home Performance Test During an Audit**



Photo: Matt Golden

**IDP23 Borate Insect Treatment of Framing**



Photo: Carl Seville

**IDP25 Drip-Through Deck Grating on Gutterless Eaves**



Photo: Peter Yost

**SS39 Clean Wood Waste for Site Erosion Control**



Photo: Carl Seville



**EA45 Interior Rigid Insulation (taped seams for air seal) on Walls**



Photo: Peter Yost

**EA45 Interior Rigid Insulation and Air Sealed (taped seams) on Ceiling**



Photo: Peter Yost

**EA45 Exterior Wall Air Sealed and Insulated with Spray Foam; Reclad (note exterior jamb extensions furring)**



Photo: Peter Yost

**EA45 Exterior Wall Spray Foam Insulation**



Photo: Peter Yost

**EA47 Furred Out and Spray Foamed Basement Walls (vapor-permeable polyurethane)**



Photo: Peter Yost

**EA49 Spray Foam Insulation at Roof Line for Conditioned Attic**



Photo: Carl Seville



**EA51 Blower Door Test Set-Up**



Photo: Matt Golden

**EA54 Thermal Bypass: Duct Chase**



Photo: Peter Yost

**EA53 Tough-to-Insulate Cathedral Ceiling**

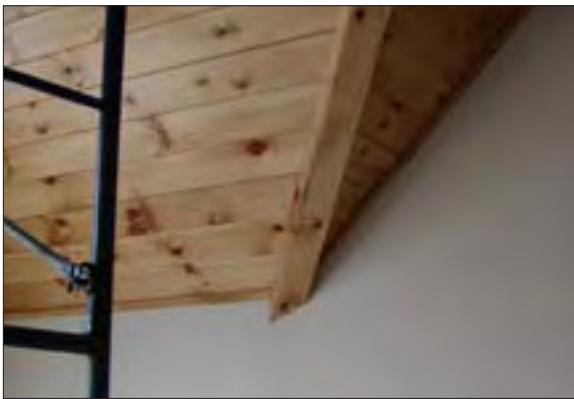


Photo: Peter Yost

**EA54 Spray Foam to Insulate and Air Seal**



Photo: Carl Seville

**EA55 Spray Foam Insulation at Rim Joists**



Photo: Carl Seville

**EA53 After-the-Fact Infrared Image of Cathedral Valley**

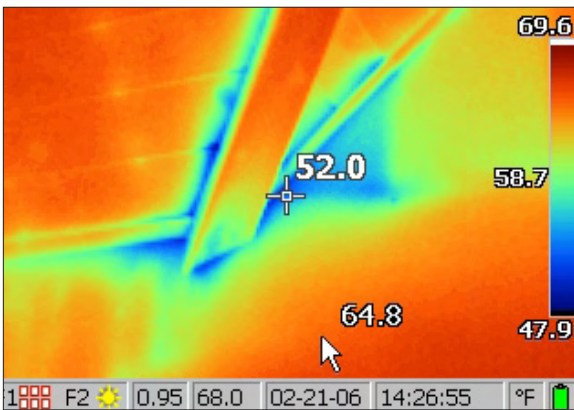


Photo: Peter Yost

**EA56 Airtight, Low-e Triple-Track Storm Window**



Photo: Peter Yost

**EA58 Interior Trim Removed to Insulate/Air Seal Sash Pockets After Sash Replacement**

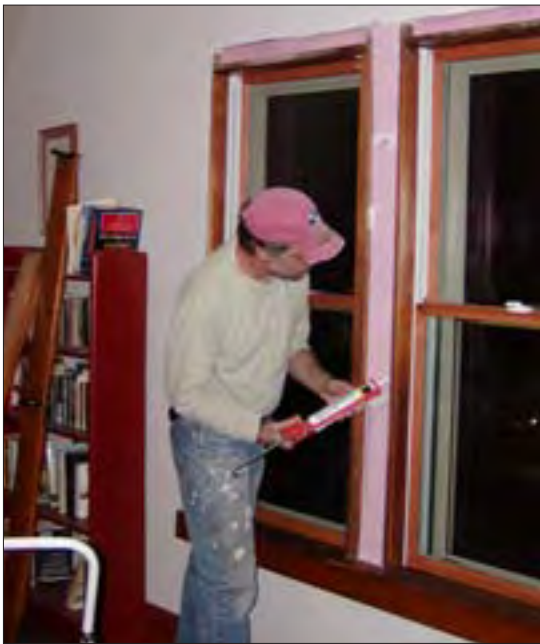


Photo: Peter Yost

**EA68 Duct Blaster Test Set-Up**

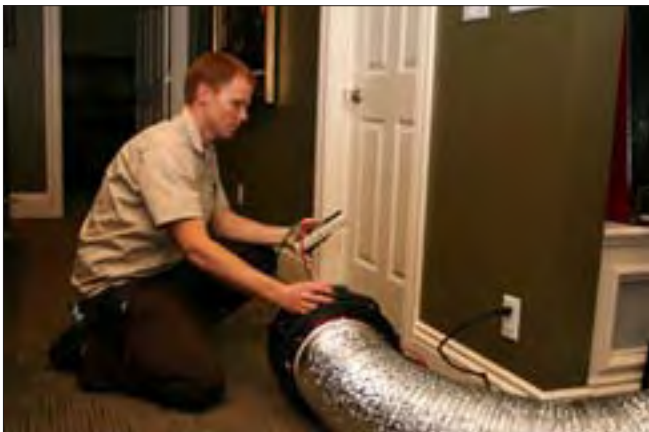


Photo: Matt Golden

**EA71 Duct Protection During Renovation**



Photo: Carl Seville

**EA77 PEX Plumbing for Efficient Distribution of Hot Water**



Photo: Carl Seville



**EA78 On-Demand Recirculation Pump for Hot Water**



Photo: Carl Seville

**EA79 One Approach to Efficient Water Heater: Gas Tankless**



Photo: Carl Seville

**EA83 Solar Tube for Daylighting**

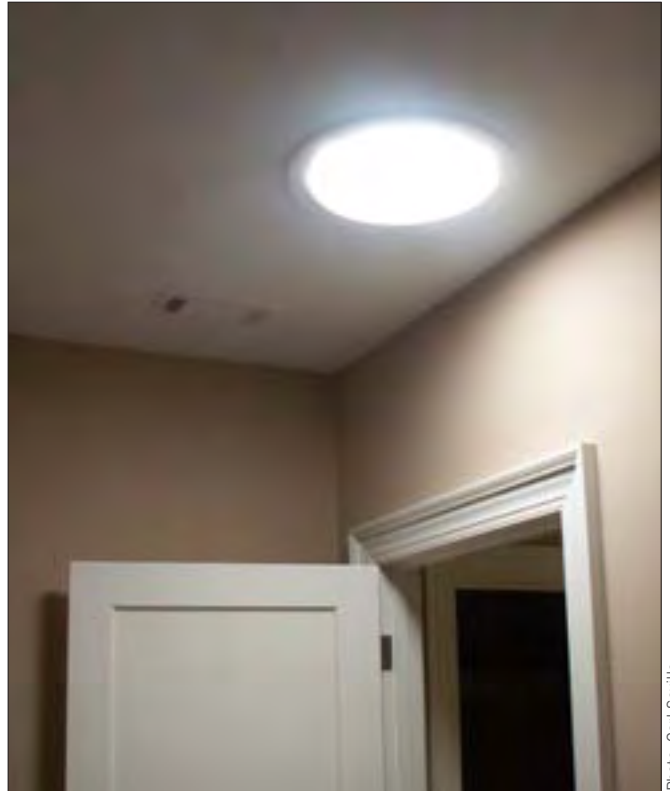


Photo: Carl Seville

**EA92 High-efficiency H-axis clothes washer**



Photo: Peter Yost

**MR107 Clean Wood Waste From a Remodel**



Photo: Carl Seville

**MR107 Onsite Recycling of Clean Wood Waste**



Photo: Carl Seville

**MR116 Advanced Framing on Interior Partitions**



Photo: Carl Seville

**MR108 Salvaged Roofing Tiles Ready for Reinstallation**



Photo: Carl Seville

**MR121 Base Board Wiring Raceway with SIP Walls**



Photo: Peter Yost

**MR113 Site-Processed Materials (brick, fill) for Patio Block Base**



Photo: Carl Seville



**MR122 PEX Piping Manifold**

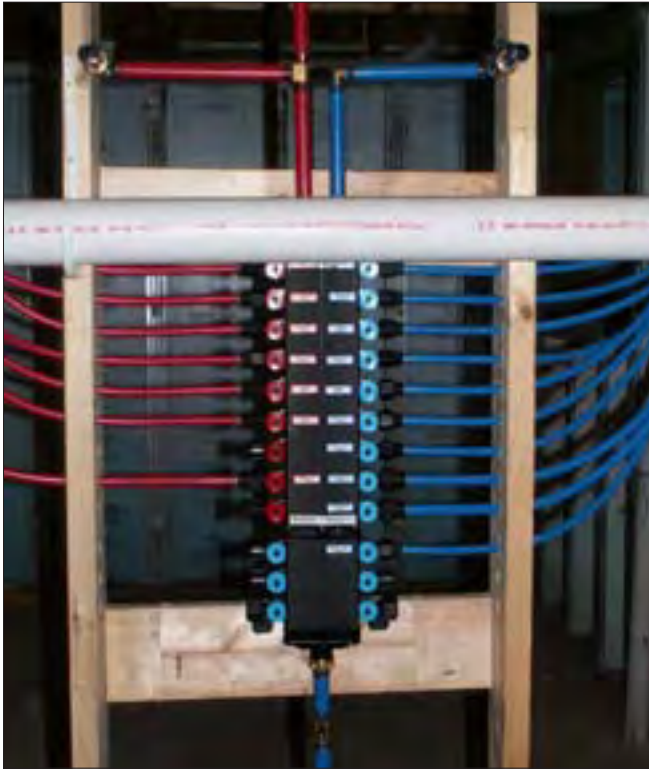


Photo: Carl Seville

**MR125 Alternative to Drain and Pan: Electronic Leak Detection for Clothes Washer**



Photo: Carl Seville

**MR124 Single-Throw Clothes Washer Shut-Off**



Photo: Peter Yost

**MR133 Birch Flooring Reused**



Photo: Mark Piepkorn

**MR140 Second-Hand Bath Counter Top Purchased From a Salvage Center**

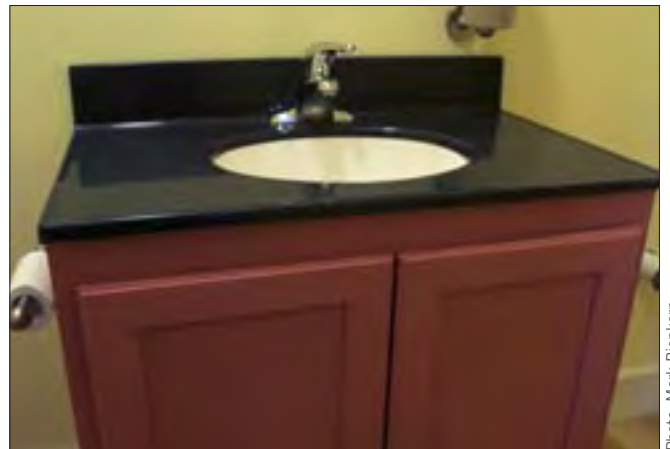


Photo: Mark Piepkorn

**MR140 Retail Architectural Salvage Center**



Photo: Kelly Bentham

**IEQ163 Airtight Sump with Radon Exhaust System**

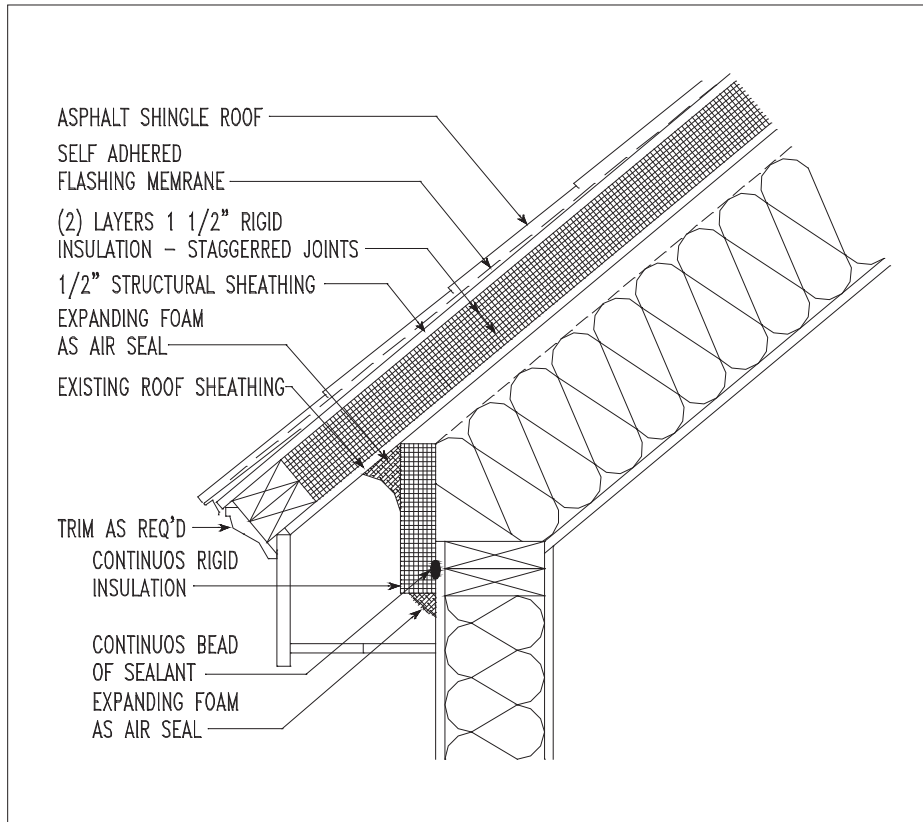


**IEQ168 Sealed Combustion, Condensing Efficiency Gas Furnace**

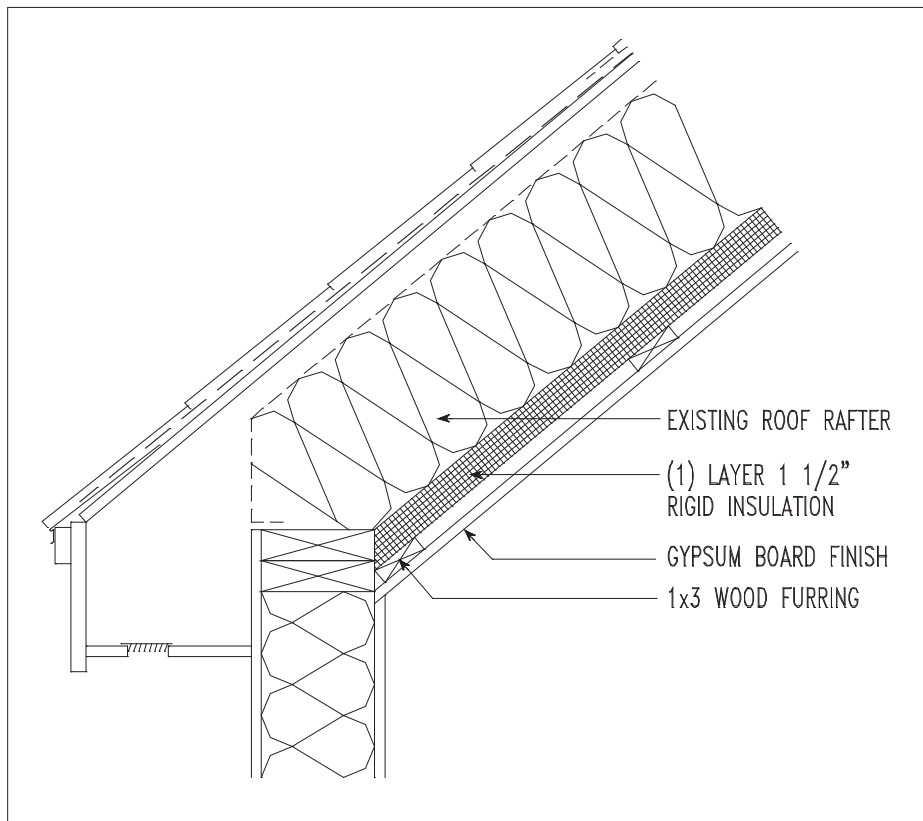


Photo: Peter Yost

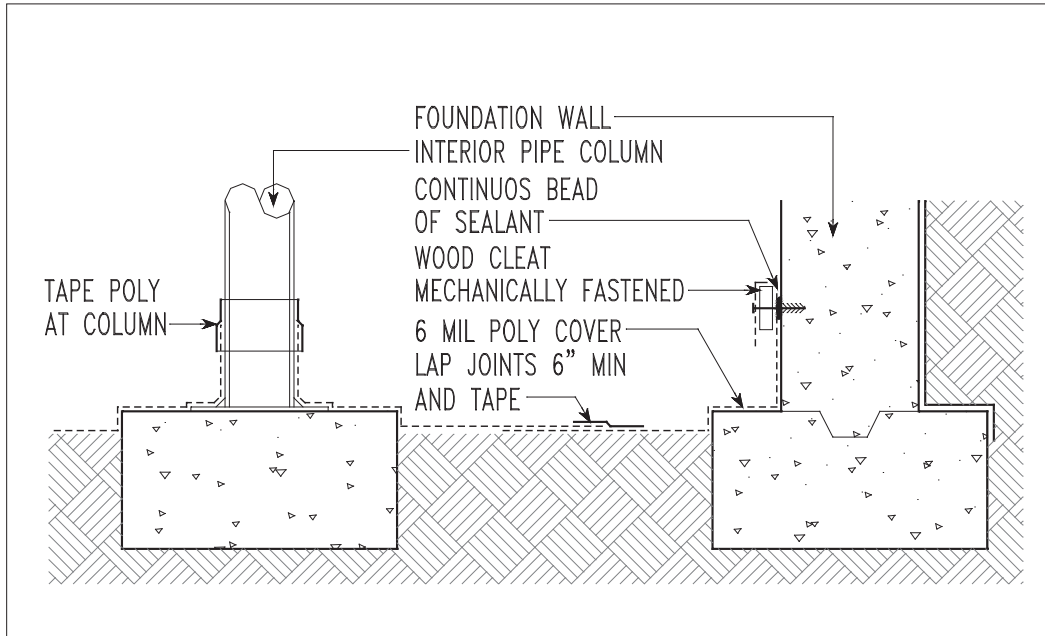
**IDP3 Roof Retrofit Insulation: Exterior Roof Retrofit**



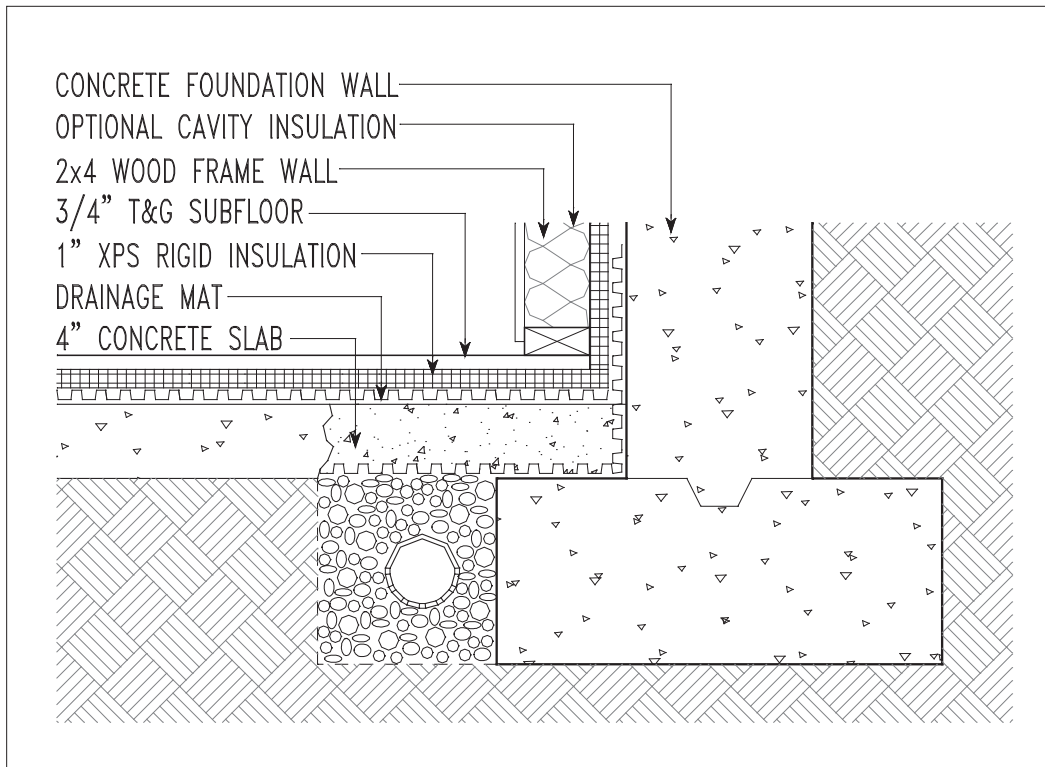
**DP3 Roof Retrofit Insulation: Interior Roof Retrofit**



**IDP20 Foundation Water Management: Crawl Space Foundation With Piers**

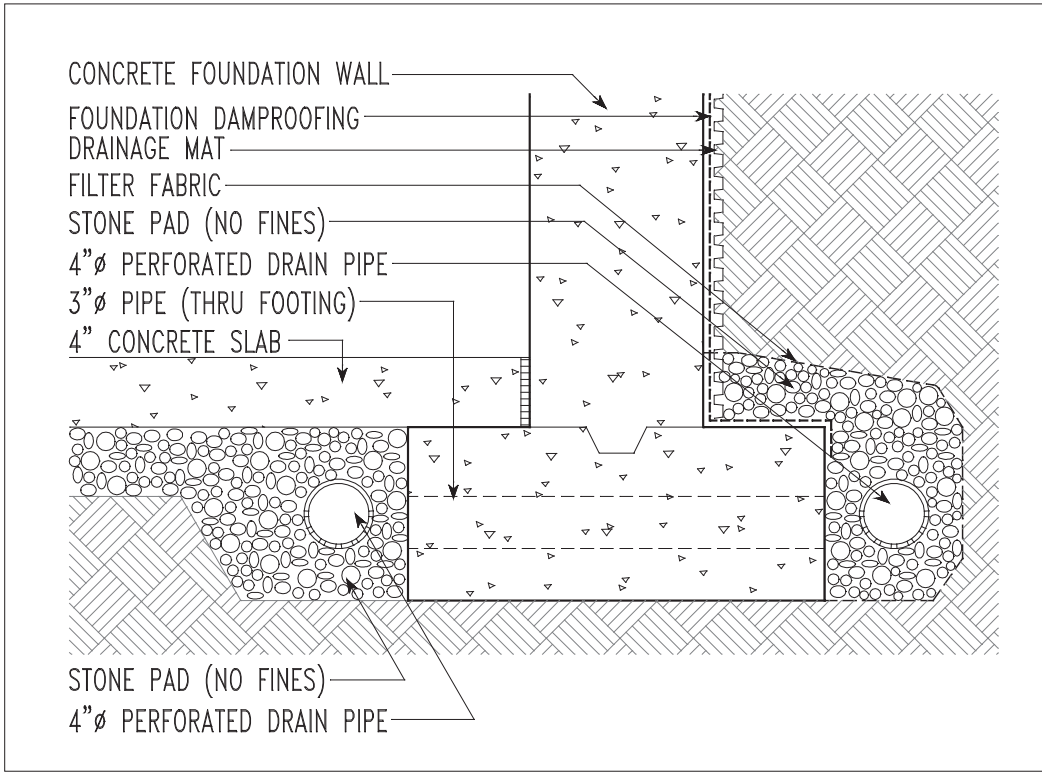


**IDP20 Foundation Water Management: Inside Perimeter Drainage - Retrofit**

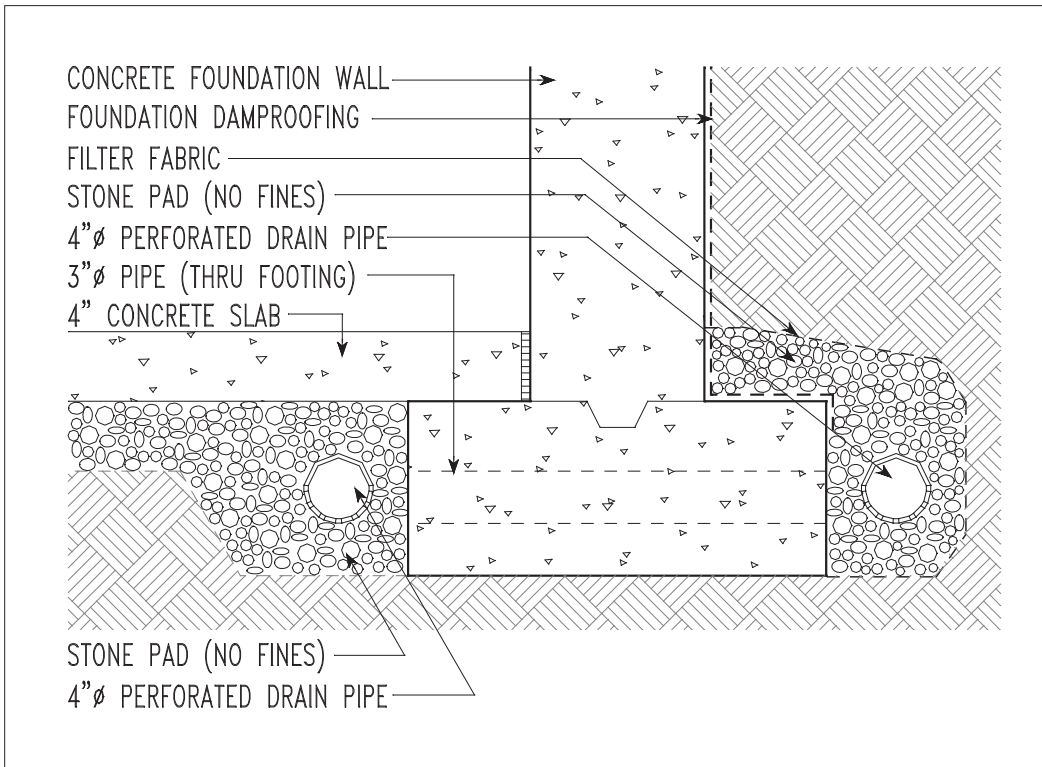




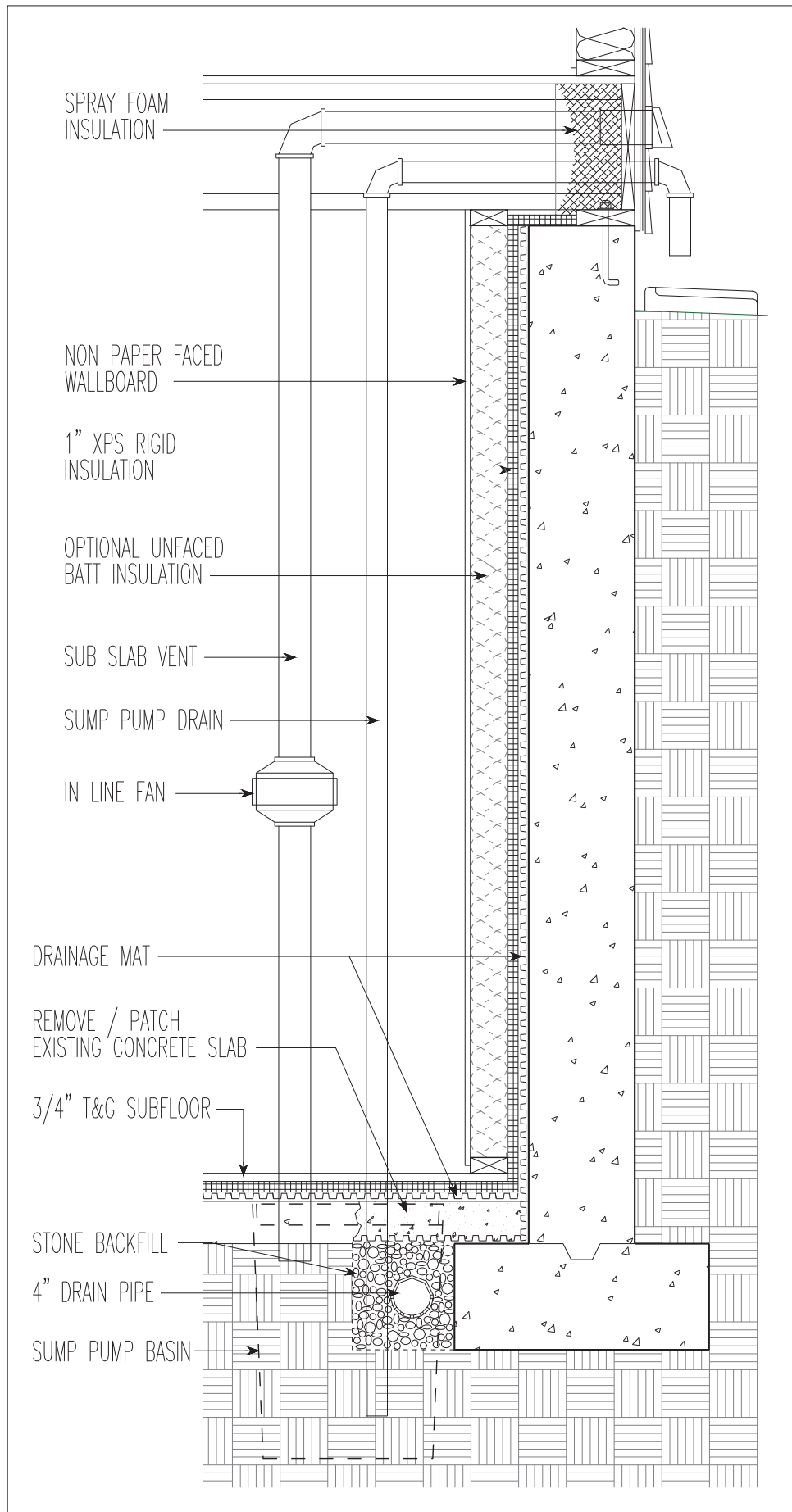
**DP20 Foundation Water Management: Inside/Outside Perimeter Drain with Drainage Mat**



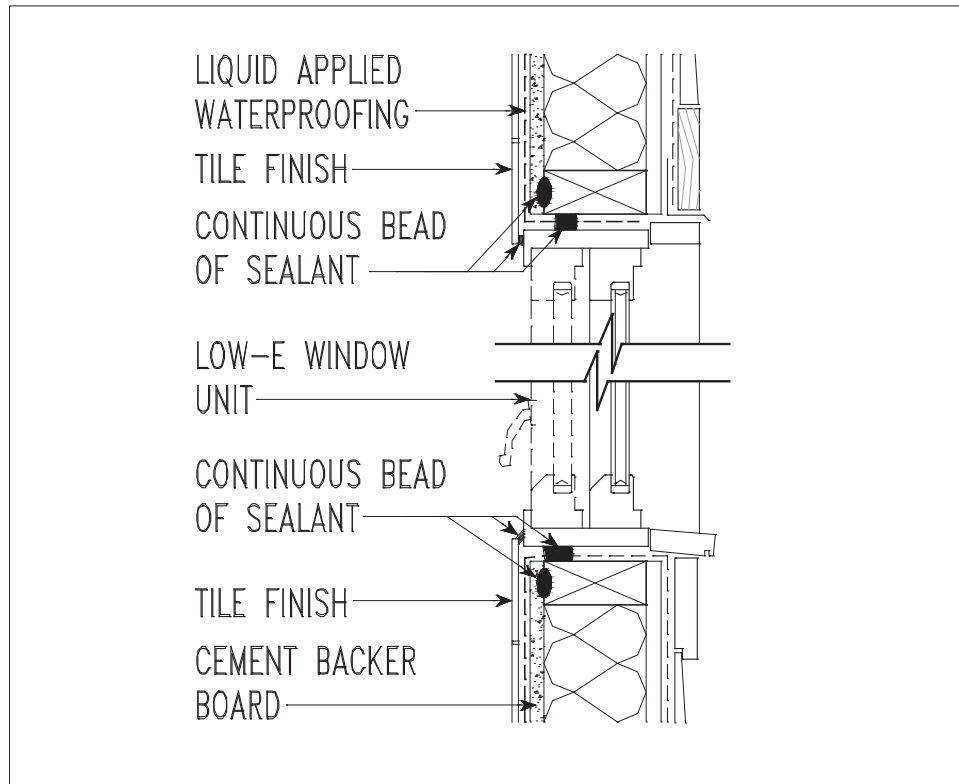
**IDP20 Foundation Water Management: Inside/Outside Perimeter Drainage**



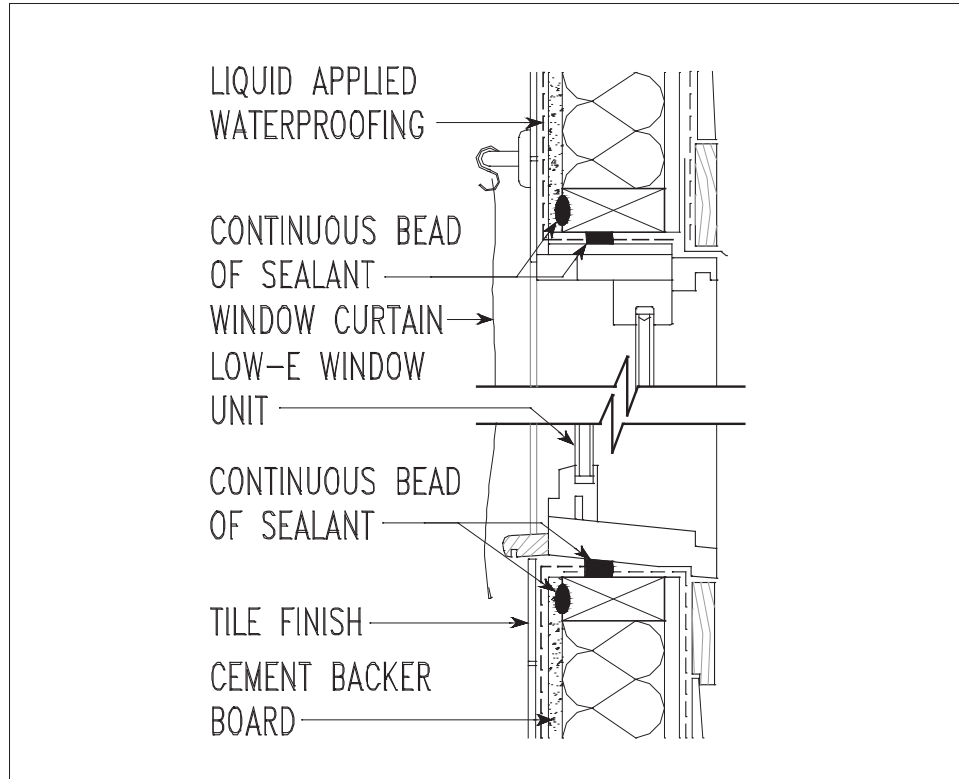
IIDP21, IDP22 and EA47 Basement Moisture and Energy Management



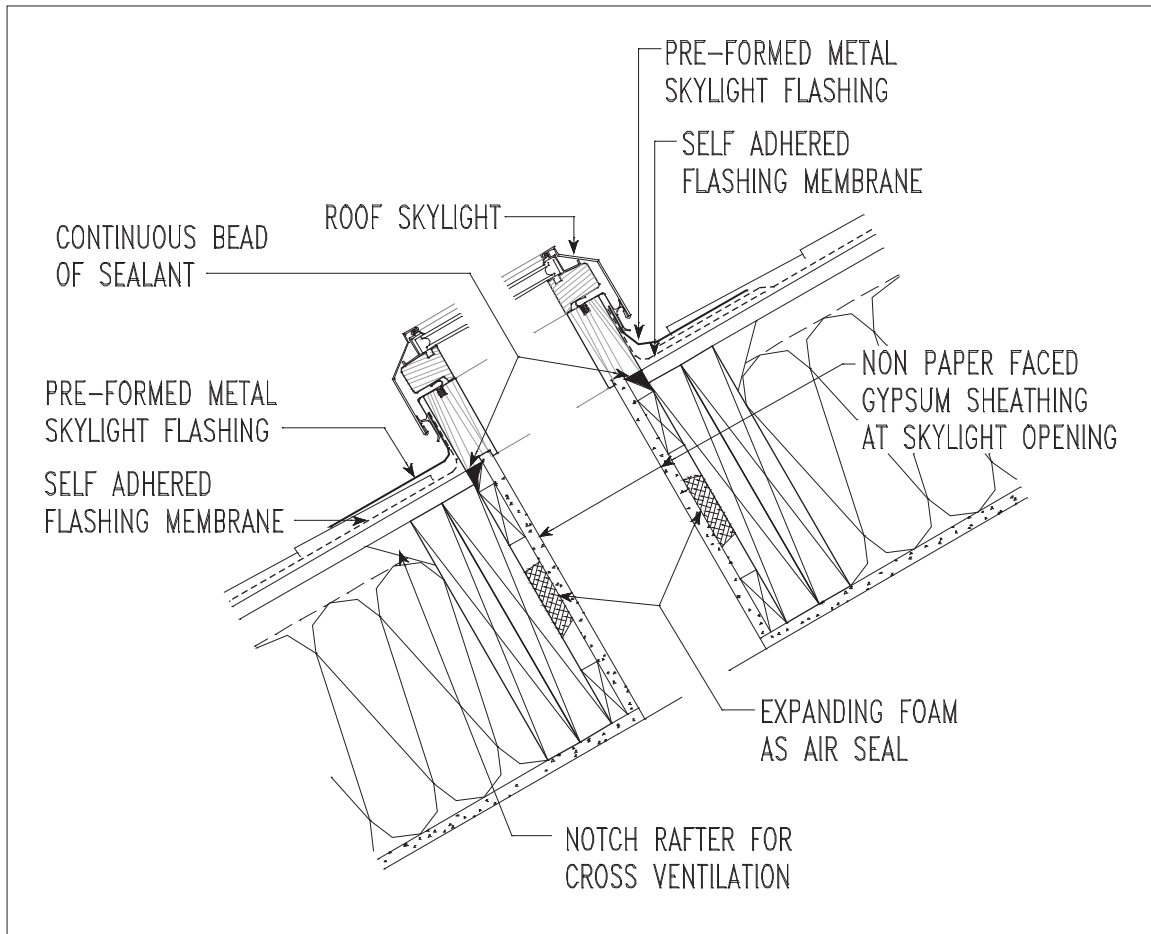
**IDP26 "Wet Room" Window: High Sill Shower Window**



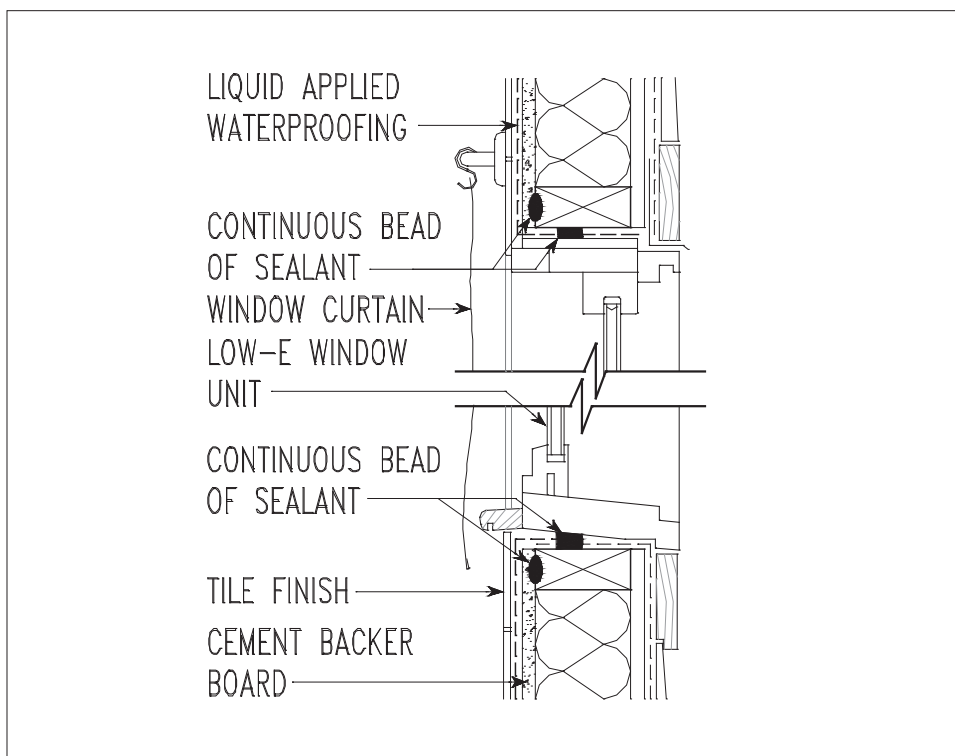
**IDP27 "Wet Room" Window: Low Sill Shower Window**



**IDP27 Air Sealing at Skylight Head and Sill**

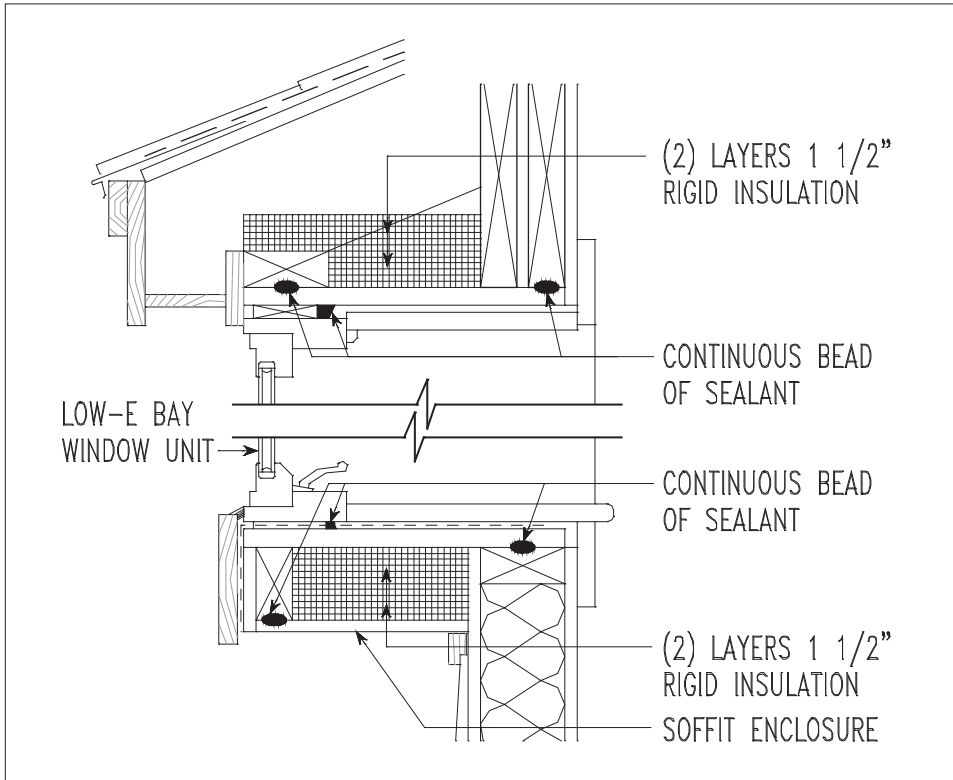


**IDP27 Air Sealing at Skylight Jamb**

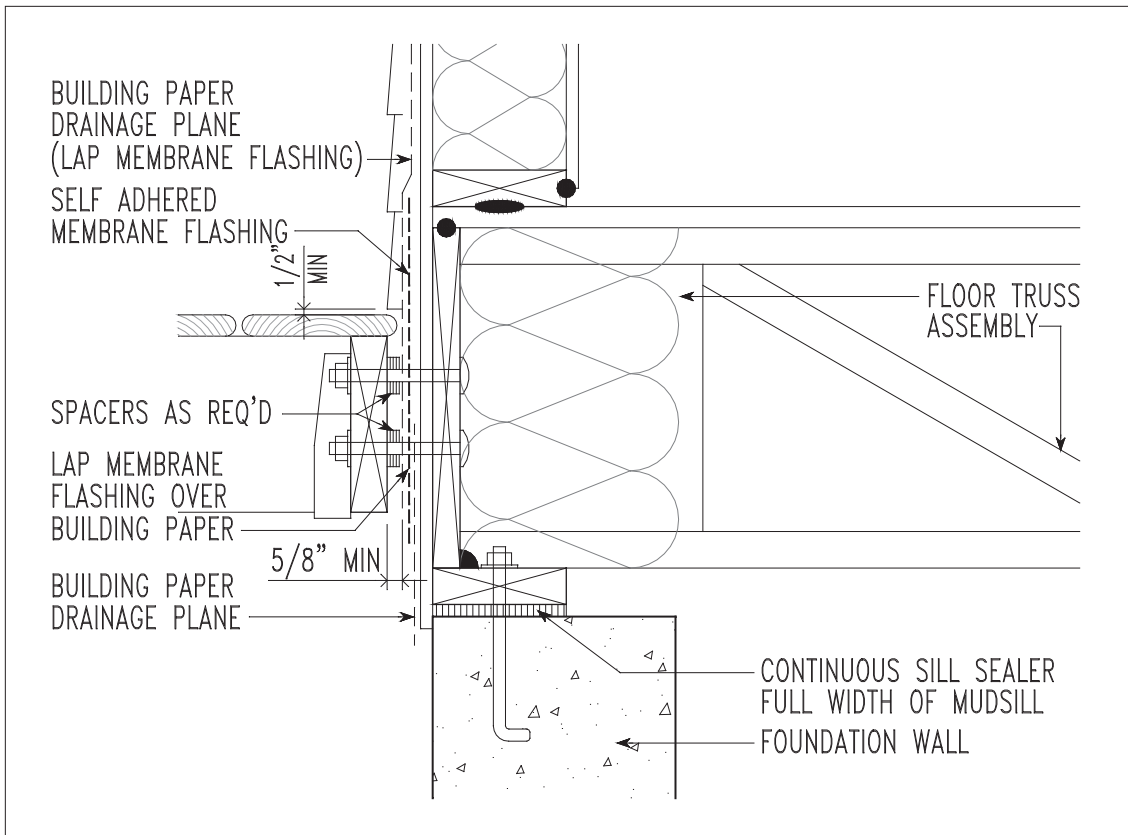




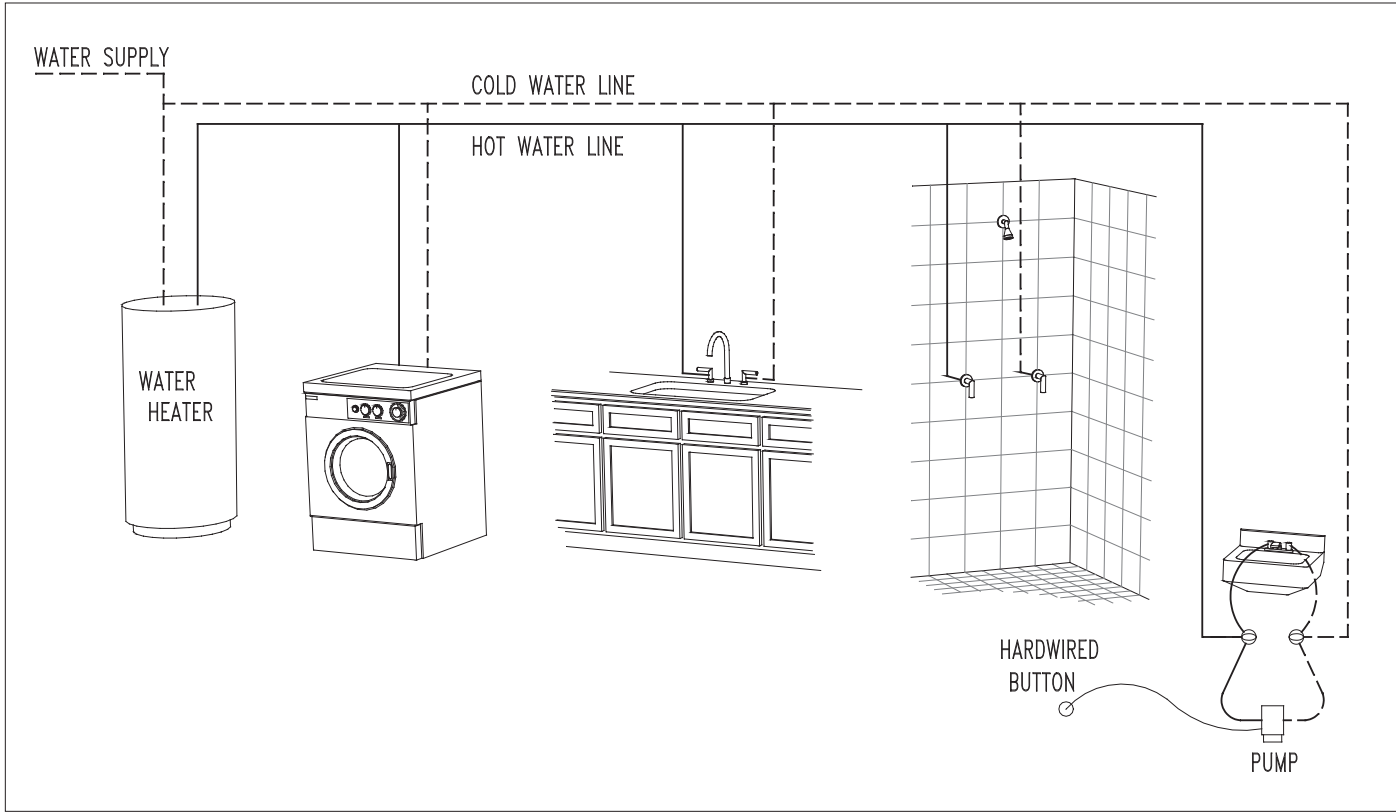
**IDP27 Air Sealing at Bay Window**



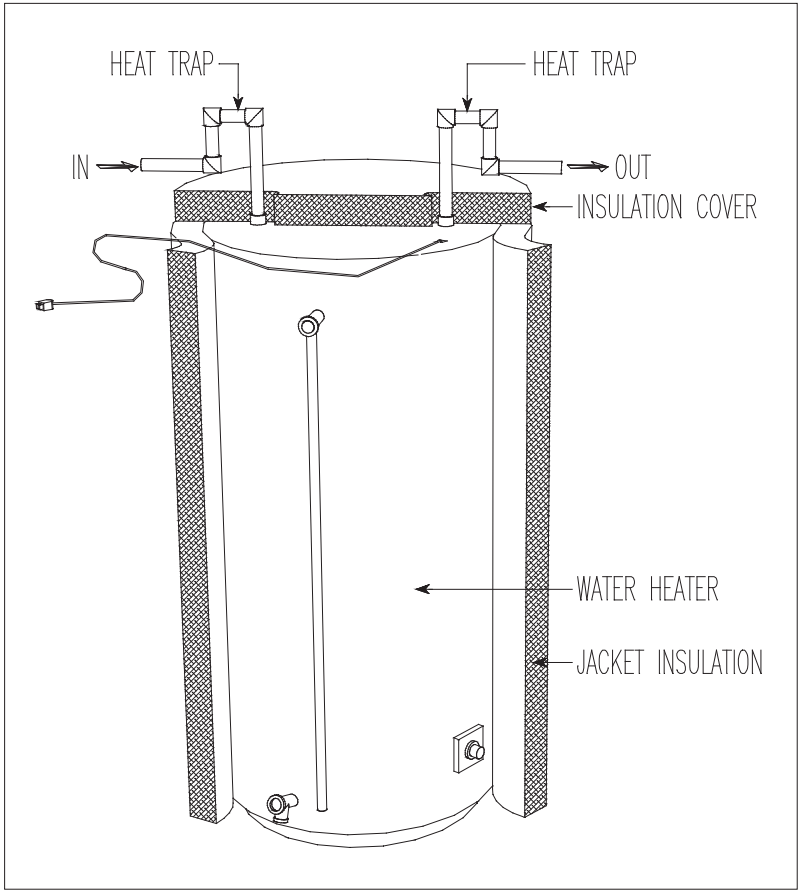
**IDP28 Deck Attachment at Band Joist**



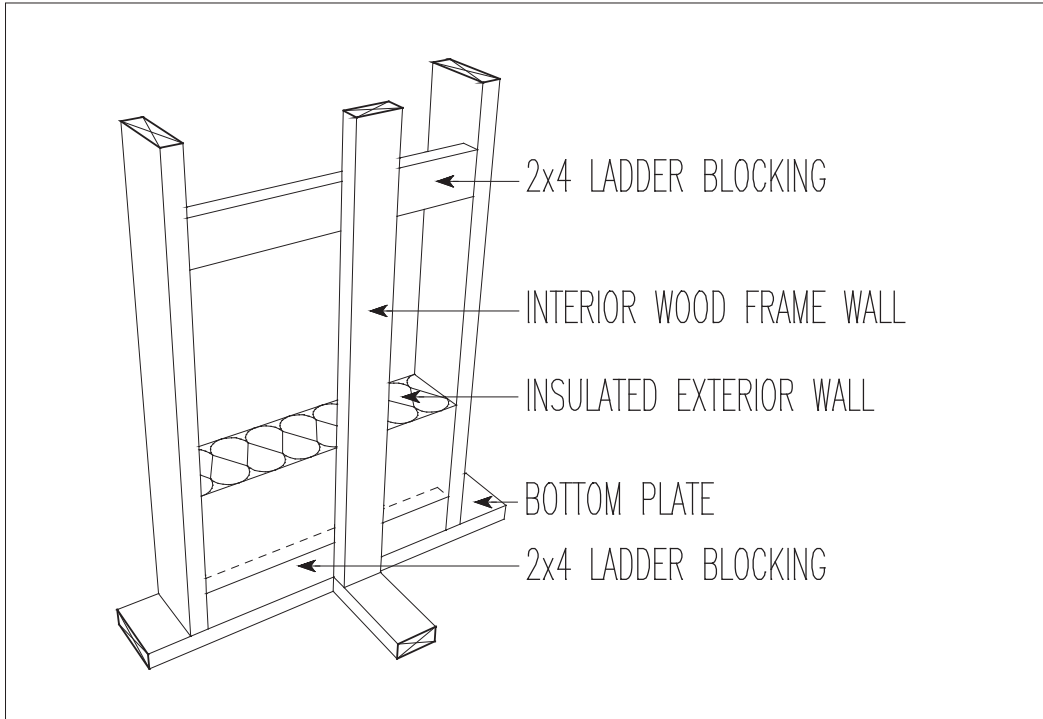
**EA78 Typical On-Demand Recirculation System for Retrofit**



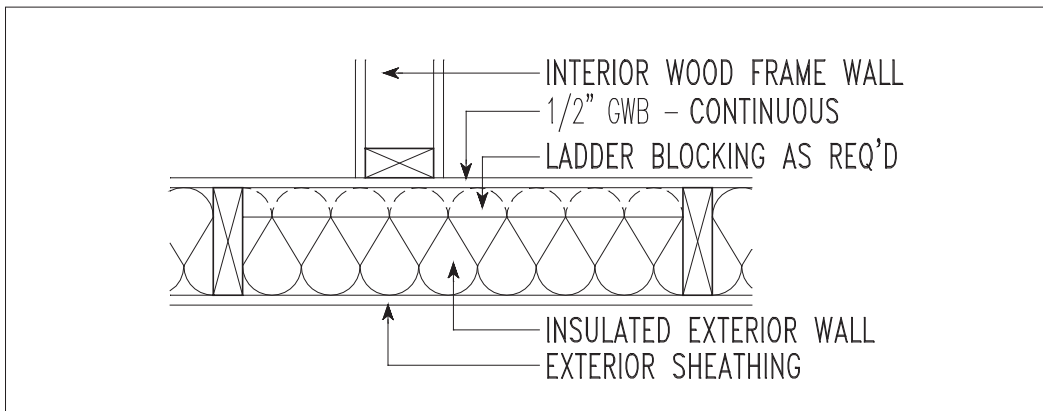
**EA80 Detail for Improving Efficiency of Existing Water Heater**



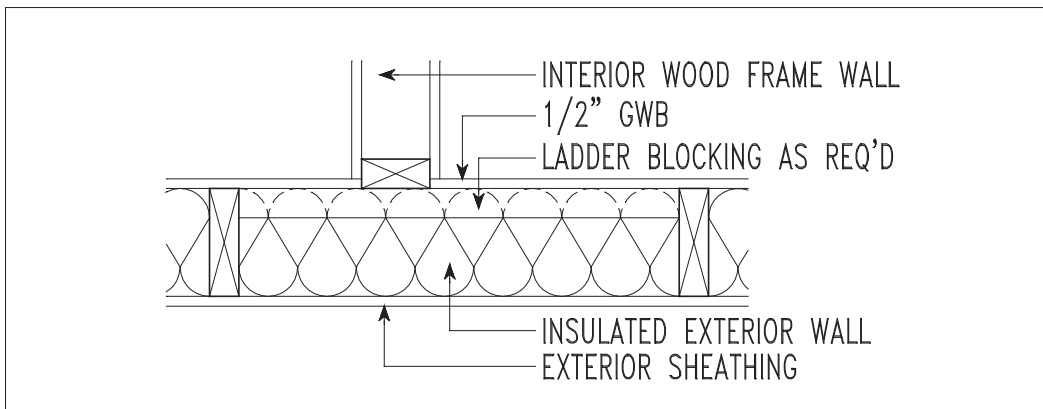
**MR116 Advanced Framing: Ladder Blocking**



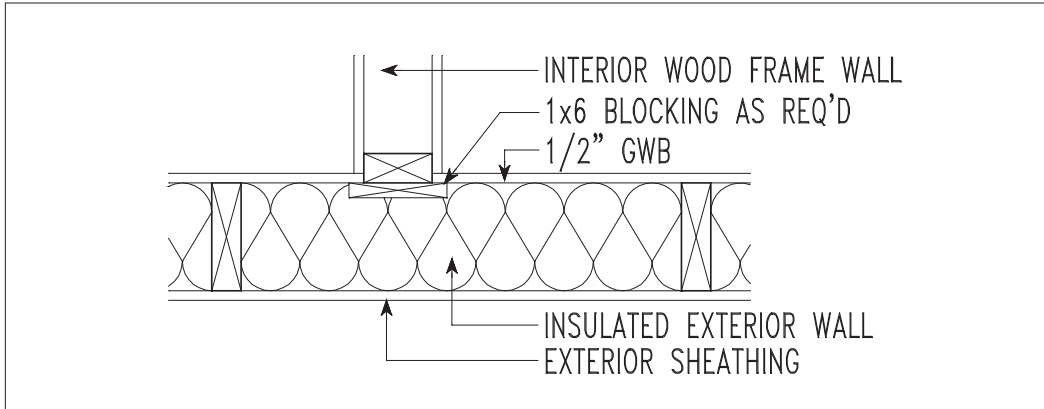
**MR116 Advanced Framing: Intersecting Wall - Ladder with Continuous Gypsum Wallboard**



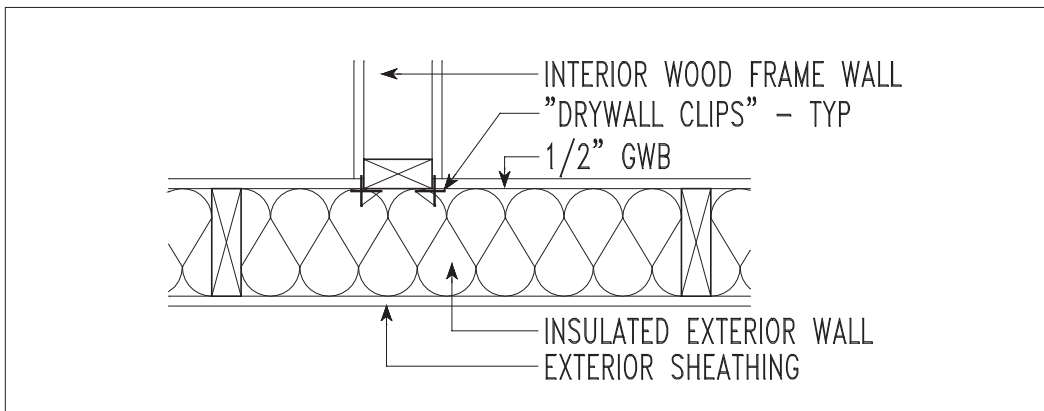
**MR116 Advanced Framing: Ladder Blocking**



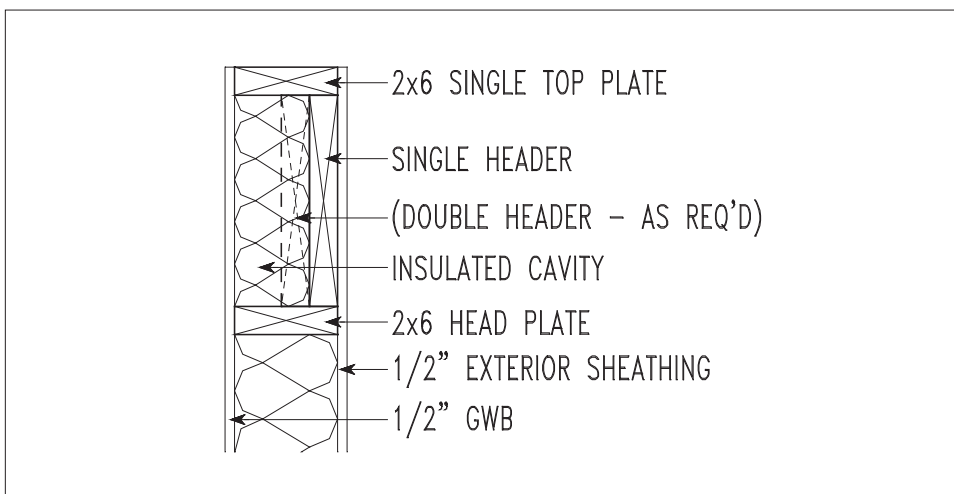
**MR116 Advanced Framing: Intersecting Wall - 1x6**



**MR116 Advanced Framing: Intersecting Wall - Drywall Clips**

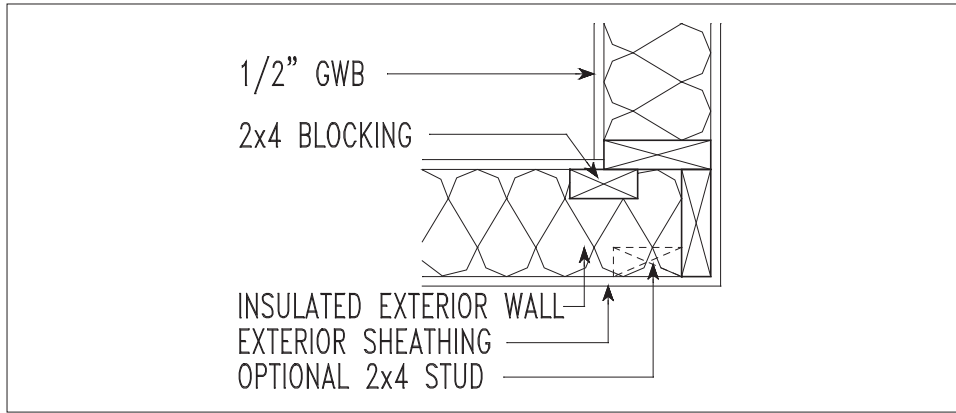


**MR116 Advanced Framing: Corner - Recessed Insulated Header**

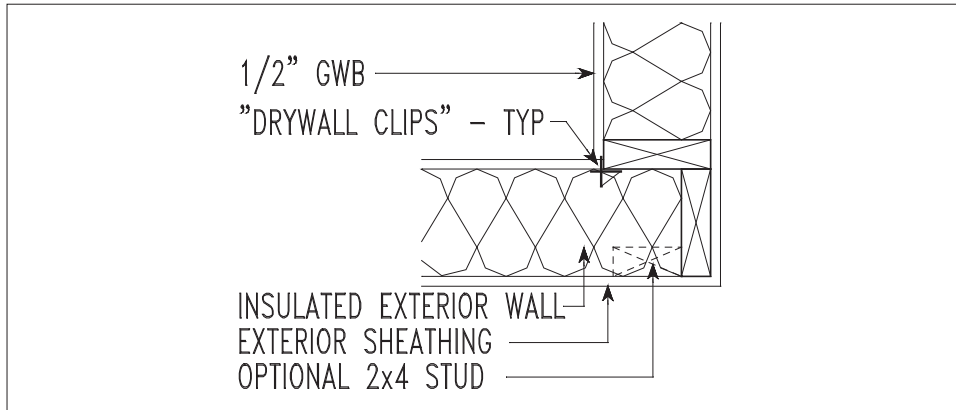




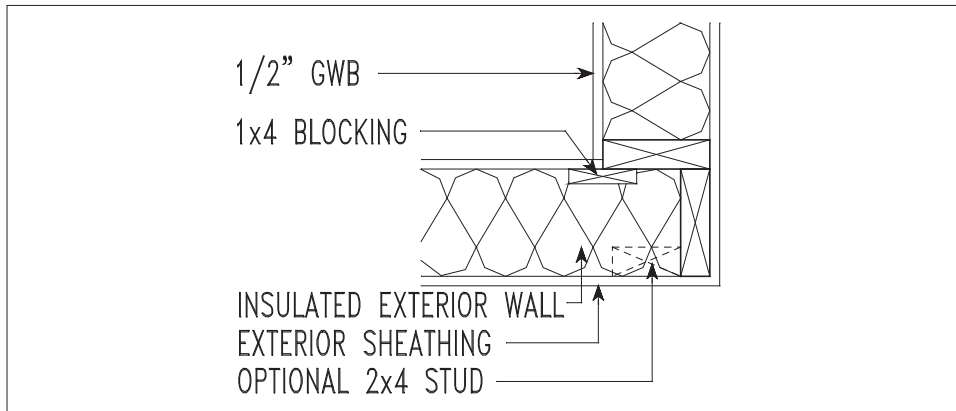
**MR116 Advanced Framing: Corner - 2x4**



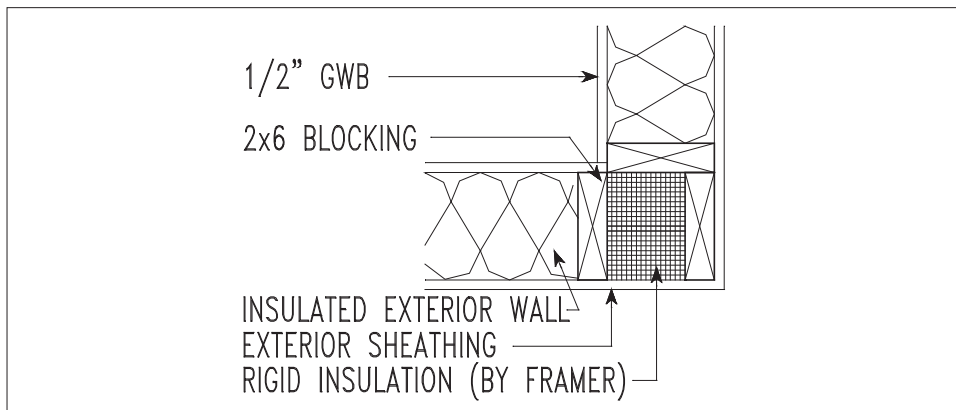
**MR116 Advanced Framing: Corner - Drywall Clips**



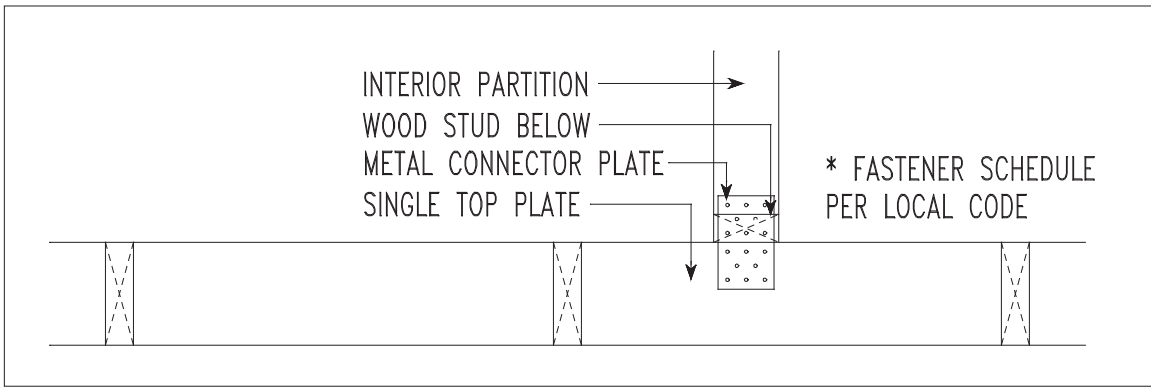
**MR116 Advanced Framing: Corner - 1x4**



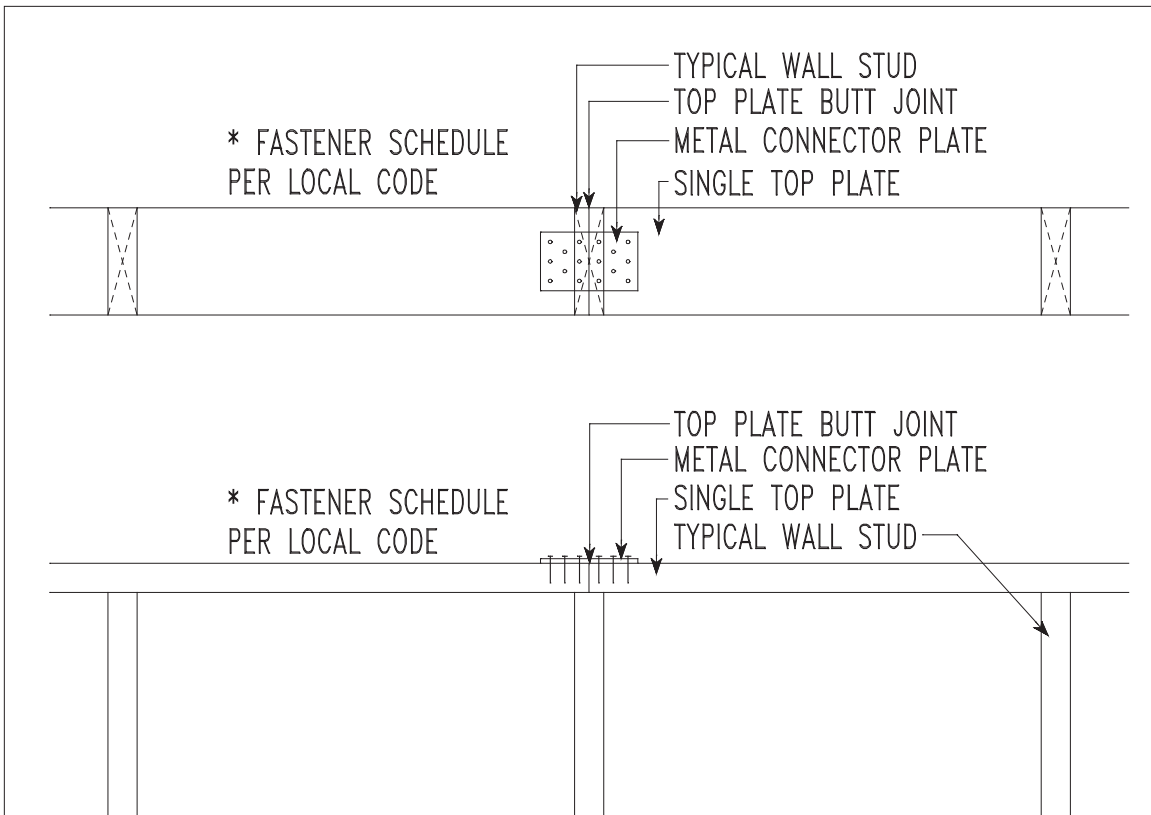
**MR116 Advanced Framing: Corner - Rigid Insulation**



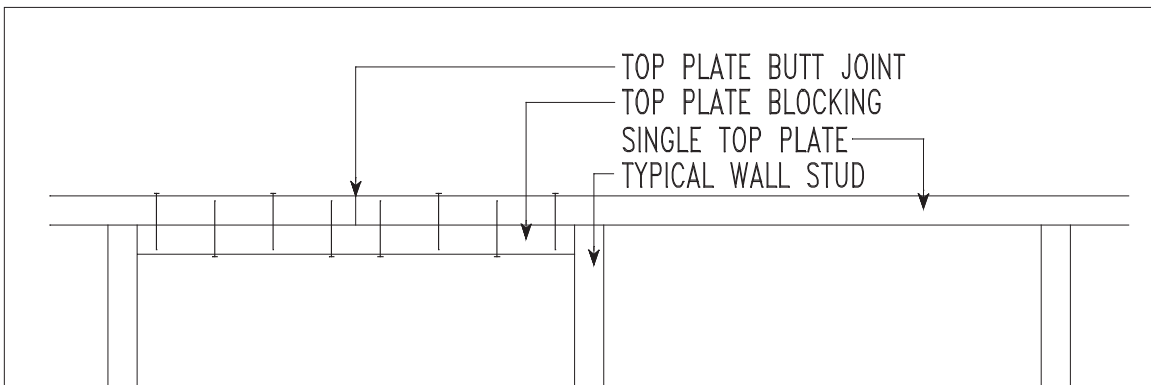
**MR116 Advanced Framing: Corner - Plate at Intersecting Wall**



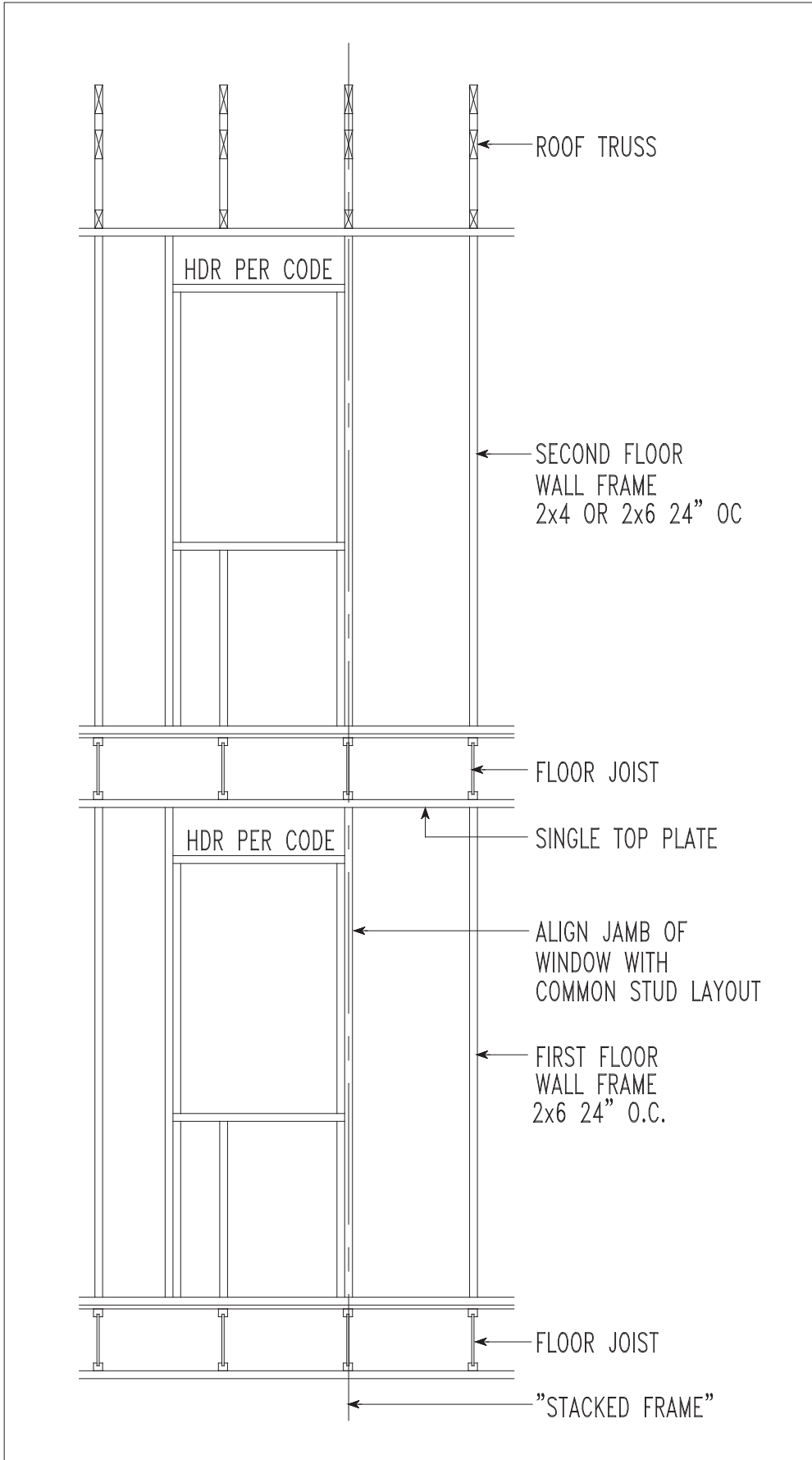
**MR116 Advanced Framing: Corner - Plate at Single Top Plate**



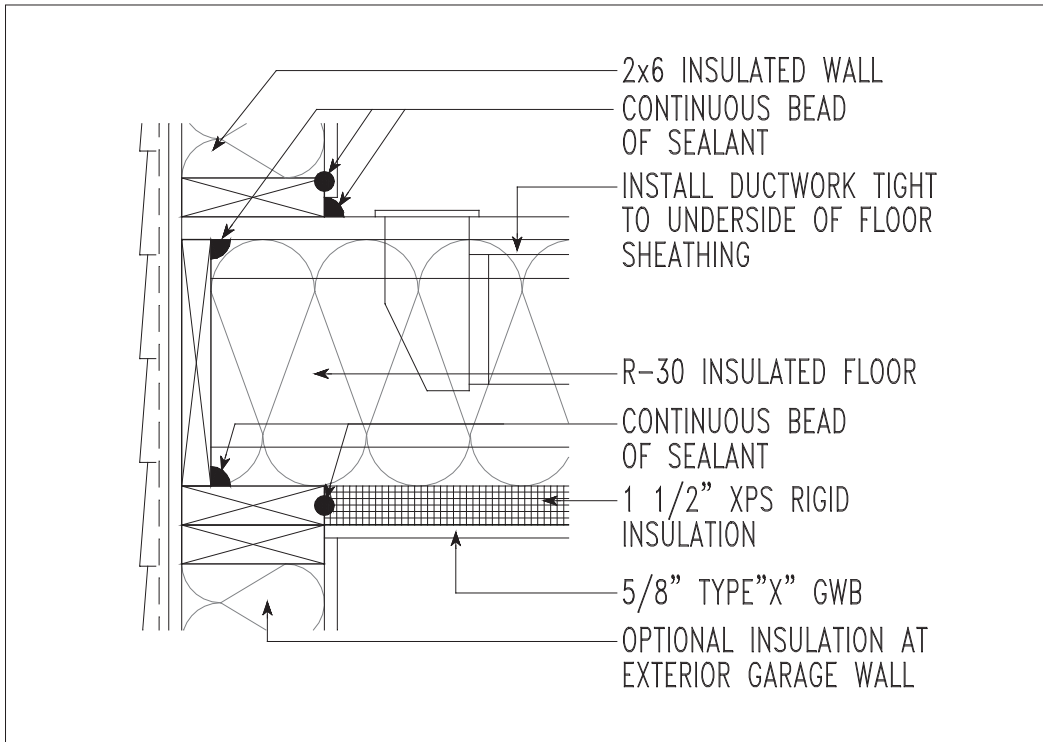
**MR116 Advanced Framing: Corner - Blocking at Single Top Plate**



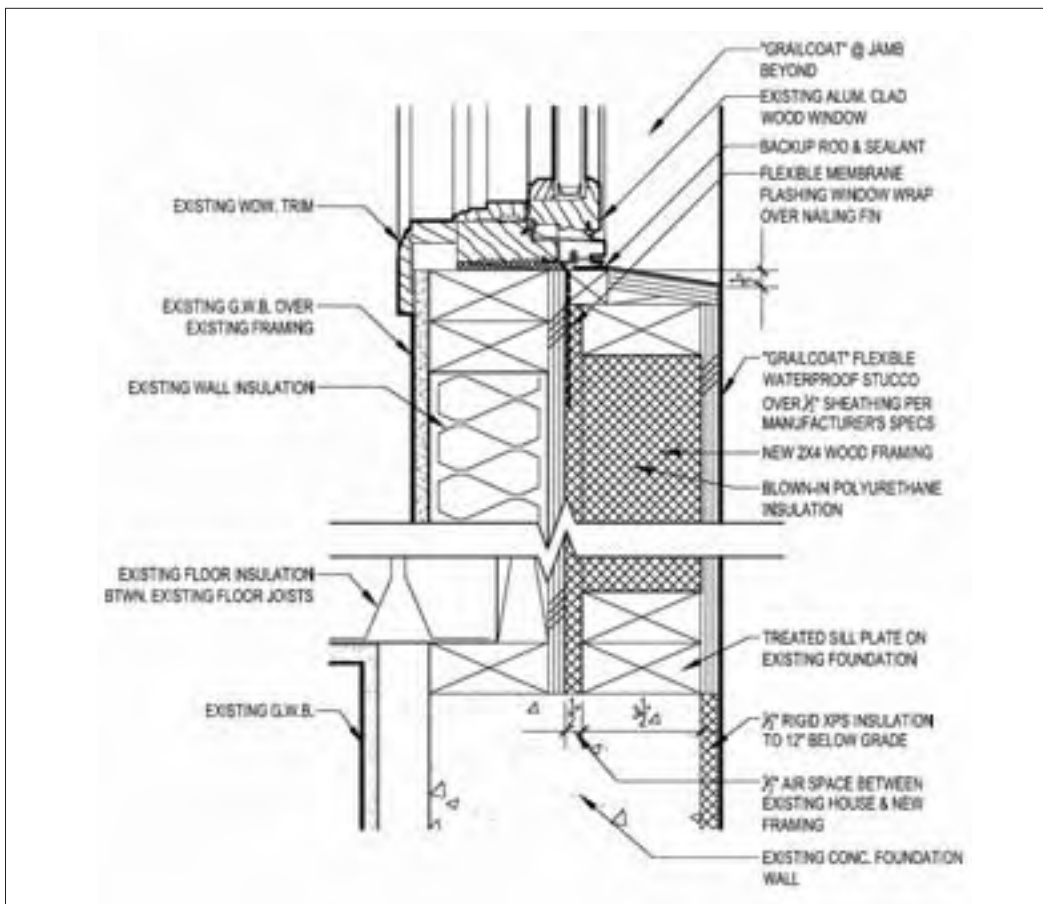
MR116 Advanced Framing: Stacked Frame Elevation



### IEQ165 Air Sealing in Garage Ceiling



### Wall Section Detail - Deep Energy Retrofit





# REGREEN Guidelines Glossary

**Active closed-loop solar water heater:** Solar water heater in which an electric pump circulates a freeze-protected heat-transfer fluid through the collector and heat exchanger within a storage tank.

**Active drainback solar water heater:** Solar water heater in which water or another heat-transfer fluid is pumped through the collector and drains back to a tank in the house when the pump turns off.

**Advanced framing:** House-framing techniques in which lumber use is optimized, saving material and improving the energy performance of the building envelope.

**Air barrier:** Building assembly components that work as a system to restrict air flow through the building envelope. Air barriers may or may not act as a vapor barrier. The air barrier can be on the exterior, the interior of the assembly, or both.

**Air handler:** Fan that a furnace, whole-house (central) air conditioner, or heat pump uses to distribute heated or cooled air throughout the house.

**Air-source heat pump:** Heat pump that relies on outside air as the heat source and heat sink; not as effective in cold climates as ground-source heat pumps.

**Airtight drywall:** Use of drywall with carefully sealed edges and joints to serve as an interior air barrier in building assemblies.

**Albedo:** Percentage of light reflected off a surface; a material with high albedo is very reflective.

**Ammonium Sulfate:** One of the flame retardants commonly used in cellulose insulation. Borates are also used.

**Annual Fuel Utilization Efficiency (AFUE):** Energy efficiency of a heating system that accounts for start-up, cool-down, and other operating losses that occur during real-life operation; AFUE is always lower than combustion efficiency.

**Asbestos:** Mineral fiber once commonly used in building materials, including insulation, fireproof siding, and resilient flooring; a known human carcinogen (causing lung cancer), asbestos is no longer used in the U.S.

**Autoclaved aerated concrete (AAC):** Masonry building material used throughout much of the world for more than 70 years; made of portland cement, sand, and

water; an autoclaving process (heating under pressure) during the setting results in the production of air pockets in the material, making it less dense and better insulating.

**Backdrafting:** Indoor air quality problem in which potentially dangerous combustion gases escape into the house instead of going up the chimney.

**Balanced ventilation:** Mechanical ventilation system in which fans exhaust stale indoor air and bring in fresh outdoor air in equal amounts; often includes heat recovery or heat and moisture recovery (see also heat-recovery ventilator and energy-recovery ventilator).

**Batch solar water heater:** A simple solar water heater in which potable water is heated where it is stored. Also called an integral collector storage (ICS) solar water heater.

**Binder:** Glue used in manufacturing wood products, such as medium-density fiberboard (MDF), particleboard, and engineered lumber. Most binders are made with formaldehyde. See urea-formaldehyde binder and methyl diisocyanate (MDI) binder.

**Biobased material:** Material made from living matter, such as agricultural crops. Biobased materials are usually biodegradable.

**Biophilia:** Theory developed by biologist Edward O. Wilson suggesting that humans have an innate affinity for nature.

**Blower door test:** Test used to determine a home's airtightness: a powerful fan is mounted in an exterior door opening and used to pressurize or depressurize the house. By measuring the force needed to maintain a certain pressure difference, a measure of the home's airtightness can be determined. Operating the blower door also exaggerates air leakage and permits a weatherization contractor to find and seal those leakage areas.

**Blowing agent:** Compound used in producing foam insulation; mixed as a liquid with the foam ingredients under pressure, the blowing agent evaporates, creating gas bubbles that provide the insulation. Until recently, most blowing agents (HCFCs and CFCs) depleted the Earth's protective ozone layer; except for extruded polystyrene, the industry has now switched to ozone-safe blowing agents.

**Boiler:** System used to heat water for hydronic heating. Most boilers are gas-fired or oil-fired, although some are electric or wood-fired; a boiler can also heat water for domestic uses through a tankless coil or an indirect water heater.

**Borate:** Chemical containing the element boron that provides fire resistance to materials such as cellulose insulation and decay resistance to wood products.

**Brominated flame retardant (BFR):** Chemicals added to various plastics and foam materials to provide fire resistance; there is growing concern these are harmful to humans.

**Btu:** British thermal unit, the amount of heat required to raise one pound of water (about a pint) one degree Fahrenheit in temperature, about the heat content of one wooden kitchen match. One Btu is equivalent to 0.293 watt-hours or 1,055 joules.

**Building envelope:** Exterior components of a house that provide protection from colder (and warmer) outdoor temperatures and precipitation; includes the house foundation, framed exterior walls, roof or ceiling, and insulation and air sealing materials.

**Capillary forces:** Forces that lift water or pull it through porous materials, such as concrete.

**Carbon-neutral:** House that, on an annual basis, does not result in a net release of carbon dioxide (a greenhouse gas that contributes to global warming) into the atmosphere.

**Cavity-fill insulation:** Insulation installed in the space created by wall, ceiling, roof, or floor framing; most commonly fiberglass-batt, spray-applied or dense-pack cellulose, or spray polyurethane.

**Chromated copper arsenate (CCA):** Type of wood preservative that has now been largely eliminated from residential wood products due to concerns about leaching and toxicity; huge quantities of CCA-treated wood remain in use, especially in residential decks.

**Cistern:** Vessel for storing water, such as that collected with a rainwater harvesting system.

**Cladding:** Materials used to enclose a house, providing protection against weather.

**Combustion efficiency:** Efficiency at which a fuel is burned in a combustion appliance when operating at its rated output; the combustion efficiency is always higher than the annual fuel utilization efficiency (AFUE).

**Commissioning:** Process of testing a home after a construction or renovation project to ensure that all of the home's systems are operating correctly and at maximum efficiency.

**Compact fluorescent lamp (CFL):** Fluorescent light bulb in which the tube is folded or twisted into a spiral to concentrate the light output; CFLs are typically three to four times as efficient as incandescent light bulbs, and last eight to ten times as long.

**Composite lumber:** Lumber, typically decking, made from plastic (often high-density polyethylene) and wood fiber or other agricultural byproducts. Composite lumber often contains recycled content.

**Composting system:** Outdoor bin or group of bins for converting vegetable scraps, weeds from the garden, and other plant matter into a rich, high-organic-content soil amendment. An alternative for indoor use is a worm bin.

**Concrete masonry unit (CMU):** Block made of concrete used for wall construction; hollow cores can be filled with concrete to reinforce walls.

**Conduction:** Movement of heat through a material as kinetic energy is transferred from molecule to molecule; the handle of an iron skillet on the stove gets hot due to heat conduction. R-value is a measure of resistance to conductive heat flow.

**Convection:** Movement of heat from one place to another by physically transferring heated fluid molecules, usually air or water. Natural convection is the movement of that heat naturally; forced convection relies on fans or pumps.

**Cripple studs:** Studs in a wall system that support headers above (and below) windows or doors; indiscriminately placed, these additional studs can result in extra heat loss because they do not insulate as well as the insulation in the wall cavity.

**Cross-linked polyethylene (PEX):** Specialized type of polyethylene plastic that is strengthened by cross-linking (chemical bonds formed in addition to the usual bonds in the polymerization process). PEX is used primarily as tubing for hot- and cold-water distribution and radiant-floor heating.

**Current loop:** In electrical wiring, a situation in which separation of hot and neutral leads results in higher-than-normal electromagnetic fields (EMFs).

**Curtain truss:** Known also as a Larson truss, a non-structural truss that extends out from a structural wall system solely for the purpose of holding cavity-fill insulation. Often used on timber-frame houses and in superinsulation retrofits, curtain trusses may be as much as 12 inches deep, providing an insulating value greater than R-40. Since they aren't structural, curtain trusses are often constructed from 2'x2's with plywood reinforcement flanges to minimize wood use.

**Daylighting:** The use of sunlight for daytime lighting needs.

**Degree day:** Measure of heating or cooling requirements based on the average outdoor temperature. To calculate the number of heating degree days of a given day, find the average of the maximum and minimum outdoor temperatures and subtract that from 65°F. The annual number of heating degree days is a measure of the severity of the climate and is used to determine expected fuel use for heating. Cooling degree days, which measure air conditioning requirements, are calculated much the same way, but subtracting the average outdoor temperature from an indoor base temperature, usually 75°F.

**Demand water heater (also called “tankless”):** Water heater that heats water only as needed; there is no storage tank and, thus, no standby heat loss.

**Double wall:** Construction system in which two layers of studs are used to provide a thicker-than-normal wall system so that a lot of insulation can be installed; the two walls are often separated by several inches to reduce thermal bridging through the studs and to provide additional space for insulation.

**Dual-flush toilet:** Toilet that provides two flush levels: a full-volume flush for use with solid wastes and a reduced-volume flush (often half the volume) when only liquid waste and paper need to be flushed.

**Duct blaster:** Calibrated air-flow measurement system developed to test the airtightness of forced-air duct systems. All outlets for the duct system, except for the one attached to the duct blaster, are sealed off and the system is either pressurized or depressurized; the work needed by the fan to maintain a given pressure difference provides a measure of duct leakage.

**Electric-resistance heat:** Heat provided by electricity in which high-resistance wires convert electric current directly into heat. See also heat pump.

**Electromagnetic field (EMF):** Field given off by electric current flow. Some health experts are concerned that the magnetic field component of EMFs may be harmful or even cancer-causing. Magnetic fields are stronger near current in which there is separation between the positive and neutral leads.

**Embodied energy:** Energy that goes into making a product; typically includes energy for transporting both the raw materials and the finished product.

**Endocrine disruptor:** Chemical that mimics natural hormones, such as estrogen, and may interfere with reproductive development or alter behavior in offspring. Includes such commonly used chemicals

as phthalate plasticizers used in PVC plastic and bisphenol-A used in epoxies and polycarbonate plastic.

**Energy efficiency rating (EER):** As most commonly used, EER is the operating efficiency of a room air conditioner, measured in Btus of cooling output, divided by the power consumption in watt-hours; the higher the number, the greater the efficiency.

**Energy factor:** Efficiency measure for rating the energy performance of dishwashers, clothes washers, water heaters, and certain other appliances; the higher the number, the greater the efficiency. A “modified energy factor” accounts for certain adjustments, according to accepted test procedures.

**Energy Star:** Labeling system sponsored by the U.S. Environmental Protection Agency and the U.S. Department of Energy for labeling the most energy-efficient products on the market; applies to a wide range of products, from computers and office equipment to refrigerators and air conditioners.

**Energy-efficient mortgage (EEM):** Special type of mortgage in which the lending institution raises the allowable mortgage amount for a given earnings level, since energy-saving features in the house will reduce the monthly operating costs, thus leaving more money available to pay the mortgage.

**EnergyGuide:** Label from the Federal Trade Commission that lists the expected energy consumption of an appliance, heating system, or cooling system, and how that consumption compares with other products in that category; the energy performance is based on specified operating conditions and average energy costs—actual performance may vary.

**Energy-recovery ventilator (ERV):** Type of heat-recovery ventilator (HRV) that captures water vapor as well as heat from the outgoing airstream in a balanced ventilation system. In winter months, this can reduce the drying that occurs when outdoor air is brought indoors and warmed.

**Engineered lumber:** Lumber made by gluing together veneers or strands of wood to create very strong framing members; stronger and less prone to warping than standard framing lumber and can be made from smaller-diameter trees, saving old-growth forests.

**Evaporative cooler:** Energy-efficient cooling system in which a fine mist of water is evaporated, lowering the air temperature; most appropriate in dry climates, as they add humidity to a house. Also known as a swamp cooler.

**Exhaust-only ventilation:** Mechanical ventilation system in which one or more fans are used to exhaust air from a house, with make-up air supplied passively. See also balanced ventilation.

**Expanded polystyrene (EPS):** Type of rigid foam insulation; unlike extruded polystyrene (XPS), EPS does not contain ozone-depleting HCFCs.

**Extruded polystyrene (XPS):** Type of rigid foam insulation that is widely used below-grade, such as underneath concrete floor slabs; in North America XPS is currently made with ozone-depleting HCFC-142b.

**Fan-coil:** Electric or hydronic heating or cooling element installed in a duct; In a highly energy-efficient home, fan coils in ventilation ducting can be used for heating or cooling the living space.

**Fiber-cement siding:** Siding material made from wood fiber and portland cement that is highly durable, moisture-resistant, and fire-proof; developed in New Zealand, the materials is becoming common as a siding material in North America.

**First cost:** Initial cost of buying or building something, as distinguished from the operating cost.

**Flashing:** Material, usually sheet metal, rubber, or plastic, installed to keep rain from entering a building; when properly installed in a wall or roof assembly, flashing sheds rain to the exterior.

**Fluorescent lighting:** Type of energy-efficient lighting introduced in the 1930s in which electric discharge within a sealed glass tube energizes mercury vapor, producing ultraviolet (UV) light; this UV light is absorbed by a phosphor coating on the inside surface of the glass tube, which in turn fluoresces, generating visible light. See also compact fluorescent lamp.

**Forced-air heating:** Heat distribution system in which heat is delivered by forcing warm air through a network of ducts. A furnace or heat pump typically generates the warm air.

**Forest Stewardship Council (FSC):** Nonprofit organization that promotes forestry practices that are sustainable from environmental and social standpoints; FSC certification on a wood product is an indicator that the wood came from a well-managed forest.

**Formaldehyde:** Chemical found in many building products; most binders used for manufactured wood products are formaldehyde compounds. Reclassified by the United Nations International Agency for Research on Cancer (IARC) in 2004 as a “known human carcinogen.” See also phenol-formaldehyde binder and urea-formaldehyde binder.

**Friable:** Ability of a solid material to break down or disintegrate. A friable insulation material may lose its effectiveness; some friable materials release hazardous dust into a house.

**Fuel cell:** Electrochemical device similar to a battery in which electricity is generated by chemically reacting hydrogen with oxygen; electricity, water vapor, and heat are the only products.

**Furnace:** System used to heat air for a forced-air heating system. Furnaces can be gas-fired, oil-fired, wood-fired, or electric.

**Glazing:** When referring to windows or doors, the transparent or translucent layer that transmits light; high-performance glazings may include multiple layers of glass or plastic, low-emissivity (low-e) coatings, and low-conductivity gas fill.

**Global warming potential:** Measure of how a given mass of greenhouse gas is estimated to contribute to global warming compared to carbon dioxide, which is given a value of 1.0 on this relative scale.

**Gravity-flush toilet:** Toilet whose flush is powered solely by the force of falling water. See also pressure-assist toilet.

**Graywater:** Wastewater from a building that does not include flush-water from toilets and (as most commonly defined) water from kitchen sinks or dishwashers. In some places, graywater can be collected and used for subsurface irrigation.

**Green building:** Design and construction of buildings that minimize impacts on the environment while helping to keep occupants healthy.

**Green electricity:** Electricity generated from renewable energy sources, such as photovoltaics (solar power), wind power, biomass, and small-scale hydropower. (Large, conventional hydropower sources usually are not included in definitions of green electricity.)

**Grid-connected power system:** Electricity generation system, usually relying on photovoltaics or wind power, that is hooked up to the utility company’s electric grid through a net-metering arrangement so that electricity can be obtained when the locally generated power is not sufficient. See also stand-alone power system.

**Ground-source heat pump:** Heat pump that relies on the relatively constant temperatures underground as the heat source and heat sink. The energy performance of ground-source heat pumps is usually better than that of air-source heat pumps.

**Gut rehab:** Building renovation in which the walls are gutted (reduced to the wall framing and sometimes sheathing) then insulated, sheathed, and finished.



**Heat exchanger:** Device that allows for transfer of heat from one material to another. An air-to-air heat exchanger, or heat-recovery ventilator, transfers heat from an outgoing airstream to an incoming airstream. A copper-pipe heat exchanger in a solar water heater tank transfers heat from the heat-transfer fluid circulating through a solar collector into the potable water in the storage tank.

**Heat pump:** Heating and cooling system in which specialized refrigerant fluid in a sealed system is alternately evaporated and condensed, changing its state from liquid to vapor by altering its pressure; this phase change allows heat to be transferred into or out of the house. See air-source heat pump and ground-source heat pump.

**Heat distribution:** System for delivering heat throughout a house. See forced-air heating and hydronic heating.

**Heat-recovery ventilator (HRV):** Balanced ventilation system in which most of the heat from outgoing exhaust air is transferred to incoming fresh air via an air-to-air heat exchanger. See also energy-recovery ventilator.

**High-efficiency toilet (HET):** Toilet that provides at least 20% water savings over the federal standard of 1.6 gallons per flush and still meets the most rigorous standards for flush performance.

**Home Performance Audit:** An energy audit that also includes inspections and testing assessing moisture flow, combustion safety, thermal comfort, indoor air quality, and durability.

**Home run plumbing system:** Water-distribution piping system in which individual plumbing lines extend from a central manifold to each plumbing fixture or water-using appliance; piping is typically cross-linked polyethylene (PEX). Because diameter of the tubing can be matched to the flow of the fixture or appliance, hot water can be delivered more quickly.

**Horizontal-axis clothes washer:** Washing machine (typically front-loading) in which the laundry drum is configured horizontally; this allows significant water savings, because the laundry is dipped into and out of the wash water as the drum rotates. See also vertical-axis clothes washer.

**Hydrochlorofluorocarbon (HCFC):** Compound commonly used as a refrigerant in compression-cycle mechanical equipment (refrigerators, air conditioners, and heat pumps) or as a blowing agent in producing foam insulation. HCFCs are damaging to the Earth's protective ozone layer.

**Hydronic heating:** Heat distribution system in which hot water produced by a boiler is circulated through pipes and baseboard radiators or tubing in a radiant floor. Also called baseboard hot-water heating.

**Impervious surface:** Surface that does not permit stormwater runoff to infiltrate the ground. See also porous paving.

**Incandescent light:** Light produced by a standard light bulb when electric current heats a tiny coiled filament to glowing; converts about 90% of the electricity into heat and only 10% into light. See also fluorescent lighting.

**Indirect water heater:** Water heater that draws heat from a boiler used for space heating; a separate zone from the boiler heats water in a separate, insulated tank via a water-to-water heat exchanger. See also tankless coil.

**Indoor air quality (IAQ):** Healthfulness of an interior environment; IAQ is affected by such factors as moisture and mold, emissions of volatile organic compounds from paints and finishes, formaldehyde emissions from cabinets, and ventilation effectiveness.

**Insulated concrete form (ICF):** Hollow insulated forms, usually made from expanded polystyrene (EPS), used for building walls (foundation and above-ground); after stacking and stabilizing the forms, the aligned cores are filled with concrete, which provides the wall structure.

**Integral collector storage (ICS) solar water heater:** A simple solar water heater in which potable water is heated where it is stored.

**Integrated design:** Building design in which different components of design, such as the building envelope, window placement and glazings, and mechanical systems are considered together. High-performance buildings and renovations can be created cost-effectively using integrated design, since higher costs one place can often be paid for through savings elsewhere—e.g. by improving the performance of the building envelope, the heating and cooling systems can be downsized, or even eliminated.

**Inverter:** Device for converting direct-current (DC) electricity into the alternating-current (AC) form required for most home uses—necessary if home-generated electricity is to be fed into the electric grid through net metering arrangements.

**Kilowatt-hour (kWh):** A measure of electricity consumption; a 100-watt light bulb burning for ten hours consumes 1 kWh.

**Leaching:** Relative to materials, this is the process by which chemicals can escape in the environment; for example, arsenic can leach out of older pressure-treated wood.

**Lead:** Toxic heavy metal often found in paints made or applied before 1978. When renovating, it is important to follow proper lead-abatement procedures to avoid lead poisoning.

**LEED for Homes:** Rating system for green homes developed by the U.S. Green Building Council; the acronym stands for Leadership in Energy and Environmental Design.

**Life cycle:** Entire life of a product or material, from raw material acquisition through disposal.

**Life-cycle assessment (LCA):** Examination of environmental and health impacts of a product or material over its life cycle; provides a mechanism for comparing different products and materials for green building.

**Life-cycle cost (LCC):** Economic cost of a product or building over its expected life, including both first cost (purchase cost) and operating cost.

**Light-emitting diodes (LEDs):** Small lights that use semiconducting (solid-state) materials to turn electricity into light; different semiconductors create different colors of light. White LEDs appropriate for residential use are continuously improving in quality, efficacy, and cost-effectiveness. LEDs are very long-lasting; unlike fluorescent lamps, LEDs do not contain mercury.

**Light organic solvent preservatives (LOSPs):** Organic pesticides, biocides, and fungicides suspended in hydrocarbon (solvent-based) carrier. “Organic” in this case refers to the fact that the chemicals are carbon-based.

**Light pollution:** Nighttime lighting that escapes into the night sky. Light pollution can interfere with the day-night patterns of ecosystems, disrupt the flights of migrating birds, and interfere with sea turtle nesting in coastal areas, and interfere with astronomical observation.

**Low-conductivity gas fill:** Transparent gas installed between two or more panes of glass in a sealed, insulated window that resists the conduction of heat more effectively than air; boosts a window’s R-value and reduces its U-factor.

**Low-emissivity (Low-e) coating:** Very thin metallic coating on glass or plastic window glazing that reduces heat loss through the window; the coating emits less radiant energy (heat radiation), which makes it, in effect, reflective to that heat; boosts a window’s R-value and reduces its U-factor.

**Make-up air:** Outside air supplied to replace household air that was used in a combustion appliance or exhausted through a ventilation system.

**Manifold:** With a home-run plumbing system, the manifold is the component that distributes the water; it has one inlet and many outlets to feed different fixtures and appliances.

**Mechanical ventilation:** Ventilation system using a fan or several fans to exhaust stale indoor air from a home as a way to ensure adequate indoor air quality. See exhaust-only ventilation and balanced ventilation.

**Medium-density fiberboard (MDF):** Panel product used in cabinets and furniture; generally made from wood fiber glued together with binder; similar to particleboard, but with finer texture, offering more precise finishing. Most MDF is made with formaldehyde-emitting urea-formaldehyde binders.

**Methyl diisocyanate (MDI) binder:** Non-formaldehyde binder used in some medium-density fiberboard and particleboard products, including straw-based particleboard.

**Net metering:** Arrangement through which a homeowner who produces electricity using photovoltaics or wind power can sell excess electricity back to the utility company, running the electric meter backwards. The utility effectively buys the power at the retail price, but the amount of electricity the utility company will “buy” in a given month is limited to the amount that the homeowner buys; any excess electricity is purchased at a much lower, wholesale price. See grid-connected power system.

**Net-zero energy:** Producing as much energy on an annual basis as one consumes on site, usually with renewable energy sources such as photovoltaics or small-scale wind turbines. Calculating net-zero energy can be difficult, particularly in grid-tied renewable energy systems, because of transmission losses in power lines and other considerations.

**Offgassing:** Release of volatile chemicals from a material or product. See also volatile organic compounds.

**On-center:** As used in house construction, the distance from the center of one framing member to the center of another; in wood-frame construction, studs are typically 16 or 24 inches on-center.

**On-demand hot water circulation:** System to quickly deliver hot water to a bathroom or kitchen when needed, without wasting the water that has been sitting in the hot-water pipes, which circulates back to the water heater.

**On-site wastewater system:** Treatment and disposal of wastewater (sewage) from a house that is not connected to a municipal sewer system; most on-site systems include a septic tank and leach field.

**Operating cost:** Cost of operating a device or building; includes energy, maintenance, repairs, etc.

**Operating energy:** Energy required to operate something, such as a house.

**Oriented strand board (OSB):** Wood sheathing or subfloor panel made from strands of wood glued together in layers oriented for strength; most OSB is made using phenol-formaldehyde or methyl diisocyanate (MDI) binder.

**Ozone depletion potential:** Amount of damage to the ozone layer a given chemical can cause compared to trichlorofluoromethane (CFC-11), which is given a value of 1.0 on this relative scale.

**Particleboard:** Panel product used in cabinets and furniture; generally made from wood fiber glued together with binder. Similar to medium-density fiberboard (MDF), but with a coarser texture. Most particleboard is made with formaldehyde-emitting urea-formaldehyde binder, although some wood particleboard and all straw particleboard uses a non-formaldehyde methyl diisocyanate (MDI) or low-emitting phenol-formaldehyde binder.

**Passive solar heating:** Building design in which solar energy provides a significant portion of the heating without the use of fans or pumps; the building itself serves as the solar collector and heat storage system.

**Payback period:** Length of time it takes to pay back the cost of an investment. For example, water and energy savings from replacing an old showerhead with a new, water-saving model can often pay back the investment in a few months; the payback period for a photovoltaic power system will be much longer.

**Peak watt:** Unit of rated power output, for example from a photovoltaic (PV) module in full sunlight, as distinct from its output at any given moment, which may be lower.

**Pellet stove:** Wood stove designed to burn pellets made from compressed sawdust or wood shavings; screw-auger feeds pellets into the firebox at a metered rate; electric fan provides combustion air.

**Phenol-formaldehyde binder:** Formaldehyde-based binder used for wood products, especially those made for exterior applications; generally lower formaldehyde emissions than urea-formaldehyde binder.

**Photovoltaics (PV):** Generation of electricity directly from sunlight. A photovoltaic (PV) cell has no moving parts; electrons are energized by sunlight and result in current flow.

**Phthalate plasticizer:** Chemical added to polyvinyl chloride (PVC) and certain other plastics to make them more flexible; some phthalates are considered endocrine disruptors.

**Pier foundation:** Building foundation consisting of piers instead of continuous walls; resource-efficient because it avoids the need for continuous foundation walls.

**Plasticizer:** Chemical compound added to a material to make it more flexible or softer. See phthalate plasticizer.

**Polyisocyanurate (polyiso):** Type of rigid foam insulation used in above-grade walls and roofs; typically has a foil facing on both sides; was made with ozone-depleting HCFC-141b blowing agent, but manufacturers have switched to ozone-safe hydrocarbons.

**Polyurethane foam:** Insulation material made from polyol and isocyanate and a blowing agent that causes it to expand; typically sprayed into wall cavities or sprayed on roofs. Both open-cell and higher-density closed-cell products are used.

**Polyvinyl chloride (PVC):** Most common plastic in building construction; widely used in such applications as drainage piping, flooring, exterior siding, window construction, and electrical wire. Also known as vinyl.

**Porous paving:** A paving material that allows rainfall to percolate through and infiltrate the ground, rather than contributing to stormwater runoff; can be asphalt, concrete, or porous grid paver.

**Portland cement:** The most common building material in the world; a fine gray powder made from limestone, gypsum, and shale or clay; when mixed with water, cement binds sand and gravel into concrete. Portland cement was invented in 1824 by Joseph Aspdin, a British stone mason, who named it after a natural stone quarried on the Isle of Portland off the British coast.

**Post-consumer recycled material:** Material recovered from a waste product that has been in use by a consumer before being discarded. See also post-industrial recycled material.

**Post-industrial (pre-consumer) recycled material:** Material recovered from the waste stream of an industrial process that has not been placed in use. See also post-consumer recycled material.

**Potable water:** Water considered safe for drinking and cooking.

**Pozzolan:** Any silicon or silicon/aluminum material that when finely divided and with moisture, reacts with calcium hydroxide to form a cementitious

compound. Common examples of pozzolans include fly ash, blast furnace slag, volcanic ash, silica fume, rice hull ash, etc.

**Pressure-assist toilet:** Toilet that uses air pressure, generated as the toilet tank refills, to produce a more forceful flush; some of the highest-performance, high-efficiency toilets (HETs) rely on pressure-assist technology.

**Pressure-treated wood:** Wood that has been chemically treated to extend its life, especially when outdoors or in ground contact. The most common pressure-treated wood until a few years ago, chromated copper arsenate (CCA), has now been phased out for most applications, due to health and environmental concerns. Other pressure-treating chemicals include ACQ, copper azole, and sodium silicate.

**Prudent avoidance:** Strategy using relatively easy and low-cost tactics to avoid exposure to something that may prove to be harmful, such as electromagnetic fields (EMFs).

**R-value:** Measure of resistance to heat flow; the higher the R-value, the lower the heat loss. The inverse of U-factor.

**Radiant energy:** Energy transmitted by electromagnetic waves.

**Radiant-floor heating:** Heat distribution system in which a floor serves as a low-temperature radiator. When used with hydronic heating, hot water is usually circulated through tubing embedded in a concrete slab; alternately, the tubing can be installed on the underside of wood subflooring, although the benefit of thermal mass is lost.

**Radiation:** Movement of energy via electromagnetic waves.

**Radon:** Colorless, odorless, short-lived radioactive gas that can seep into homes and result in lung cancer risk. Radon and its decay products emit cancer-causing alpha, beta, and gamma particles.

**Rainscreen:** Construction detail appropriate for all but the driest climates to prevent moisture entry and to extend the life of siding and sheathing materials; most commonly produced by installing thin strapping to hold the siding away from the sheathing by a quarter-inch to three-quarters of an inch.

**Raised heel truss:** Pre-constructed roof truss designed to allow room at the eaves (above exterior walls) for large amounts of insulation. (With standard roof trusses, there is not enough depth for adequate insulation near the eaves.)

**Rankine-cycle compressor:** Technology used in a standard air conditioner and refrigerator to achieve cooling; a refrigerant is alternately compressed and allowed to expand, cooling air in the process.

**Reflective roofing:** Roofing material that reflects most of the sunlight striking it to help reduce cooling loads; the Energy Star Cool Roof program certifies roofing materials that meet specified standards for reflectivity.

**Refrigerant:** Compound used in refrigerators, air conditioners, and heat pumps to transfer heat from one place to another (using the Rankine cycle), thus cooling or heating a space. Most refrigerants today are hydrochlorofluorocarbons (HCFCs), which deplete the ozone layer.

**Renewable energy:** Energy produced using solar, wind, hydropower, or biomass energy sources; either thermal energy or electricity can be produced.

**Room air conditioner:** Air conditioner installed in a window or through a wall; usually used to cool a relatively small area—although with a very energy-efficient, tight house, a single room air conditioner may be able to cool the entire space. See also whole-house (central) air conditioner.

**Sealed combustion:** Combustion system for space heating or water heating in which outside combustion air is fed directly into the combustion chamber and flue gasses are exhausted directly outside.

**Seasonal energy efficiency ratio (SEER):** Energy performance rating of a whole-house (central) air conditioner or heat pump operating in the cooling mode; it is the ratio of the estimated seasonal cooling output divided by the seasonal power consumption in an average climate.

**Sheathing:** Material, usually plywood or oriented strand board (OSB), but sometimes wooden boards, installed on the exterior of wall studs, rafters, or roof trusses; siding or roofing installed on the sheathing—sometimes over strapping to create a rainscreen.

**Solar collector:** Device for capturing solar energy and transferring heat to water or air that circulates through.

**Solar gain:** Sunlight entering a building; for example, a passive solar direct-gain system.

**Solar heat gain coefficient (SHGC):** The fraction of solar gain admitted through a window, expressed as a number between 0 and 1.

**Space planning:** While tradespeople may include different things under the term 'layout,' or 'space planning,' comprehensive space planning is the process of converting the needs expressed by the client into



the drawings and supporting documentation that outline the plan for the team. For the interior designer, space planning includes the placement of all fixed and unfixed elements, from plumbed and wired appliances to furniture and the way people move around in the space. Plumbing and HVAC contractors are concerned primarily with hidden elements. With comprehensive space planning, the whole team is involved to ensure that the design is optimized across disciplines.

**Stormwater:** Runoff from rain that is either carried offsite in storm sewers or allowed to infiltrate the ground; stormwater can be reduced through the use of porous paving and other infiltration strategies.

**Structural insulated panel (SIP):** Building panel usually made of oriented strand board (OSB) skins surrounding a core of expanded polystyrene (EPS) foam insulation. SIPs can be erected very quickly with a crane to create an energy-efficient, sturdy home.

**Sump:** Reservoir or pit in the basement of a house into which water can drain, especially during flooding; a sump pump is used to pump collected water out of this reservoir.

**Suntempering:** Practice of using a modest area of south-facing windows to provide limited passive solar heating to a house.

**Superinsulate:** To insulate extremely well; a house with very efficient windows and tight construction results in very low heating and cooling costs.

**Swale:** Low area of ground used for drainage and, often, the infiltration of stormwater.

**Tankless coil:** Heat exchanger used for heating water that is integrated into a boiler. Effective in the winter months when the boiler is operating for space heating, but tankless coils waste energy in warmer months, since they require the boiler to fire up every time hot water is drawn.

**Therm:** Unit of heat equal to 100,000 British thermal units (Btus); commonly used for natural gas.

**Thermal bridging:** Heat flow that occurs across more conductive components in an otherwise well-insulated material, resulting in disproportionately significant heat loss. For example, steel studs in an insulated wall dramatically reduce the overall energy performance of the wall, because of thermal bridging through the steel.

**Thermal mass:** Heavy, high-heat-capacity material that can absorb and store a significant amount of heat; used in passive solar heating to keep the house warm at night.

**Thermosiphon solar water heater:** Solar water heater that operates passively (through natural convection), circulating water through a solar collector and into an insulated storage tank situated above the collector; pumps and controls are not required.

**Top plate:** In wood-frame construction, the framing member that forms the top of a wall. In advanced framing, a single top plate is often used in place of the more typical double top plate.

**Track-off mat:** Mat at a house entrance across which people scuff their feet to remove moisture, dirt, and other particulates; important for keeping contaminants out and reducing cleaning requirements.

**Tubular skylight:** Round skylight that transmits sunlight down through a tube with internally reflective walls, even through an attic space; it delivers daylighting through a ceiling light diffuser. Most tubular skylights are 12 to 16 inches in diameter and deliver daytime lighting comparable to several 100-watt incandescent light bulbs.

**U-factor:** Measure of the heat conducted through a given product or material—the number of British thermal units (Btus) of heat that move through a square foot of the material in one hour for every one degree Fahrenheit difference in temperature across the material (Btu/ft<sup>2</sup>°F hr). U-factor is the inverse of R-value.

**United States Green Building Council (USGBC):**

Organization devoted to promoting and certifying green buildings. USGBC created the LEED rating systems.

**Universal design:** Design that makes a building accessible to as many individuals as possible, including older people and those with physical handicaps.

**Unvented (or vent-free) gas heater:** Gas-burning space heater that is not vented to the outdoors. While unvented gas heaters burn very efficiently, indoor air quality experts strongly recommend against their use because combustion gasses, including high levels of water vapor, are released into the house.

**Urea-formaldehyde binder:** Interior-grade, formaldehyde-based binder used for particleboard, medium-density fiberboard (MDF), and hardwood plywood; generally higher formaldehyde emissions than phenol-formaldehyde binder.

**UV light treatment:** Water treatment system in which water passes through a column where it is exposed to ultraviolet light to kill any pathogens.

**Vapor diffusion:** Movement of water vapor through a material; water vapor can diffuse through even solid materials if the permeability is high enough.

**Vapor profile:** The relative individual component and total combined vapor permeability of building assemblies. The vapor profile addresses not only how the assembly protects itself from getting wet by vapor diffusion, but also how it dries if/when the assembly gets wet.

**Vapor retarder:** Layer that inhibits vapor diffusion through a building envelope; examples include polyethylene sheeting, foil facing, kraft paperfacing on batt insulation, and low-permeability paints. Most building codes define a vapor retarder as 1 perm or less, with many common vapor retarders being significantly less than 1 perm. Note that many building scientists prefer a focus on the vapor profile of a building assembly rather than just the individual vapor permeability of the designated vapor retarder.

**Variable Air Volume (VAV) air handler:** System for controlling an HVAC system in which the volume of air provided to conditioned space is varied to control comfort.

**Ventilation:** Replacement of stale indoor air with fresh outdoor air — usually with fans, but sometimes naturally through building design elements. See also heat recovery ventilator.

**Vertical-axis clothes washer:** Top-loading washing machine with a tub that rotates back and forth and spins on a vertical axis, i.e., the center of rotation is a line extending up from the center of the tub. See also horizontal-axis clothes washer.

**Vinyl:** Common term for polyvinyl chloride (PVC). In chemistry, vinyl refers to a carbon-and-hydrogen group ( $H_2C=CH-$ ) that attaches to another functional group, such as chlorine (vinyl chloride) or acetate (vinyl acetate).

**Volatile organic compound (VOC):** An organic compound that evaporates readily into the atmosphere; as defined by the U.S. Environmental Protection Agency, VOCs are organic compounds that volatilize and then become involved in photochemical smog production.

**Waste management plan:** Plan that addresses the collection and disposal of waste generated during construction or renovation, usually including the collection and storage of recyclable materials.

**Wastewater:** Used water from toilets, showers, sinks, dishwashers, clothes washers, and other sources in the home, including all contaminants; can either flow into a municipal sewer system or be treated with an onsite wastewater disposal system. See also graywater—a specialized category of wastewater.

**WaterSense:** Program developed and administered by the U.S. Environmental Protection Agency to promote and label water-efficient plumbing fixtures.

**Weatherization:** The Department of Energy defines weatherization as cost-effective energy efficiency measures for existing residential and multifamily housing with low-income residents. When weatherization includes the house as a system, it is often called whole-house weatherization.

**Whole-house (central) air conditioner:** Air conditioning system that serves an entire house; cooled air is delivered through a system of ducts. See also room air conditioner.

**Whole-wall R-value:** Average R-value of a wall, taking into account the thermal bridging through wall studs.

**Xeriscaping:** Type of landscaping that requires little if any irrigation; suited to dry and drought-prone climates; generally relies on regionally adapted native plants.

## Building Profile Worksheet

Client: \_\_\_\_\_ Date: \_\_\_\_\_  
E-mail: \_\_\_\_\_ Phone: \_\_\_\_\_  
Mobile: \_\_\_\_\_ Fax: \_\_\_\_\_  
Client Address: \_\_\_\_\_ Building Address: \_\_\_\_\_  
\_\_\_\_\_  
\_\_\_\_\_  
\_\_\_\_\_

### Contact Notes:

\_\_\_\_\_  
\_\_\_\_\_

### Context Details (complete only info with bearing on the specific project):

Ave. Annual Rainfall: \_\_\_\_\_ Seasonal Distribution: \_\_\_\_\_  
HDD: \_\_\_\_\_ CDH: \_\_\_\_\_ HDD Distribution: \_\_\_\_\_  
CDH Distribution: \_\_\_\_\_  
Heating Design Temperature: \_\_\_\_\_ Cooling Design Temperature: \_\_\_\_\_  
Ave. Monthly Dewpoints: \_\_\_\_\_  
  J  F  M  A  M  J  J  A  S  O  N  D  
Prevailing Wind Direction (if any): \_\_\_\_\_ Prevailing Wind Speed (if any): \_\_\_\_\_  
Top Wind Speed: \_\_\_\_\_ Relevant Recent Weather Events: \_\_\_\_\_  
Building Perimeter Soil Characteristics: \_\_\_\_\_  
Site Soil Characteristics: \_\_\_\_\_  
Soil Surface Conditions: \_\_\_\_\_  
Prevailing Slope of Site: \_\_\_\_\_  
Building Perimeter Grade: \_\_\_\_\_  
Water Table Depth: \_\_\_\_\_ Irrigation System Check: \_\_\_\_\_  
Relevant Neighboring Site Conditions: \_\_\_\_\_  
\_\_\_\_\_

### Building Characteristics:

Age of Building: \_\_\_\_\_ Rehab/Renovation Dates: \_\_\_\_\_  
R/R Details: \_\_\_\_\_  
\_\_\_\_\_  
Hazardous Materials Assessment (lead, asbestos, radon, etc): \_\_\_\_\_  
\_\_\_\_\_  
Original Plans/Documents Available? \_\_\_\_\_ R/R Plans/Documents Available? \_\_\_\_\_  
Lot Size: \_\_\_\_\_ Building Footprint: \_\_\_\_\_ Building Total Sq. Ft.: \_\_\_\_\_  
# Floors Above-Grade: \_\_\_\_\_ # Floors Below-Grade: \_\_\_\_\_  
Building Orientation (front entrance): \_\_\_\_\_  
Below-Grade Assemblies: \_\_\_\_\_  
Above-Grade Assemblies: \_\_\_\_\_  
Roof assemblies: \_\_\_\_\_  
Glazing (as % of floor area): \_\_\_\_\_ Glazing Properties: \_\_\_\_\_  
\_\_\_\_\_

**Building Science Details:**

Site Run-Off Management: \_\_\_\_\_

Windbreaks? \_\_\_\_\_ Shading? \_\_\_\_\_

Building Run-Off Management: \_\_\_\_\_

Surface Details (hardscape, variegation, etc.) \_\_\_\_\_

Foundation Perimeter Drainage Details: \_\_\_\_\_

Footer/Foundation Wall Junction Details:

Drainage Plane - \_\_\_\_\_

Capillary Break - \_\_\_\_\_

Below-Grade Wall Details:

Capillary Break - \_\_\_\_\_

Thermal Barrier - \_\_\_\_\_

Air Barrier - \_\_\_\_\_

Vapor Profile - \_\_\_\_\_

Drainage Plane - \_\_\_\_\_

Below-Grade Floor Details:

Capillary Breaks - \_\_\_\_\_

Thermal Barrier - \_\_\_\_\_

Air Barrier - \_\_\_\_\_

Vapor Profile - \_\_\_\_\_

Above-Grade Wall Details:

Capillary Breaks - \_\_\_\_\_

Thermal Barrier - \_\_\_\_\_

Air Barrier - \_\_\_\_\_

Vapor Profile - \_\_\_\_\_

Drainage Plane - \_\_\_\_\_

Roof Assembly Details:

Thermal Barrier - \_\_\_\_\_

Air Barrier - \_\_\_\_\_

Vapor Profile - \_\_\_\_\_

Drainage Plane - \_\_\_\_\_

Pest Management Details:

Insects - \_\_\_\_\_

Other - \_\_\_\_\_

Drainage Plane Design Details:

Overhangs - \_\_\_\_\_

Sheltered Entryways - \_\_\_\_\_

Wall Penetrations - \_\_\_\_\_

Roof Penetrations - \_\_\_\_\_

Window Flashing - \_\_\_\_\_

Deck Attachment Details - \_\_\_\_\_

Other Flashing - \_\_\_\_\_

Air Barrier Design Details:

Soffits Extending to Conditioned Space Boundary (CSB) - \_\_\_\_\_

Vertical Chases Extending to CSB - \_\_\_\_\_

CSB penetrations - \_\_\_\_\_

HVAC/Water Heating Details:

Combustion Sources - \_\_\_\_\_

Heating Details - \_\_\_\_\_

Cooling Details - \_\_\_\_\_



DEH/Humidifier Details – \_\_\_\_\_  
Ducting Details - \_\_\_\_\_  
Ventilation Details - \_\_\_\_\_  
Spot Exhaust Details - \_\_\_\_\_  
Water Heating – \_\_\_\_\_

**Fail-safe plumbing details:**

Leak Sensors – \_\_\_\_\_ Easy-Throw/Single-Throw Shut-offs - \_\_\_\_\_  
Drained Pans - \_\_\_\_\_ Concealed Drainage Plane in Wet Walls - \_\_\_\_\_

**Maintenance/Commissioning Details:**

\_\_\_\_\_  
\_\_\_\_\_  
\_\_\_\_\_

**Wildfire Management Details:**

\_\_\_\_\_  
\_\_\_\_\_  
\_\_\_\_\_

**Building Performance/Conditions Metrics:**

Whole Building Air Tightness (Blower Door) - \_\_\_\_\_  
HVAC Duct Tightness (Duct Blaster) - \_\_\_\_\_  
Room-to-Room Pressure Measurements - \_\_\_\_\_  
Low-e Window Testing - \_\_\_\_\_  
Infrared Imaging/Thermometer Readings - \_\_\_\_\_  
Humidity (air moisture) Readings - \_\_\_\_\_  
Moisture Content (material moisture) Readings - \_\_\_\_\_  
HVAC Flow (air velocity) Measurements - \_\_\_\_\_

**Overall Comments:**

\_\_\_\_\_  
\_\_\_\_\_  
\_\_\_\_\_  
\_\_\_\_\_  
\_\_\_\_\_  
\_\_\_\_\_

**Recommendations:**

\_\_\_\_\_  
\_\_\_\_\_  
\_\_\_\_\_  
\_\_\_\_\_  
\_\_\_\_\_  
\_\_\_\_\_  
\_\_\_\_\_

**Follow-Up:**

\_\_\_\_\_  
\_\_\_\_\_  
\_\_\_\_\_  
\_\_\_\_\_

## Credits for Photography and Illustration

### Cover photo

Photograph by Charles Miller, *Fine Homebuilding Magazine* © 2006, The Taunton Press, Inc.

### Table of Contents

Top Photograph by Justin Fink, *Fine Homebuilding Magazine* © 2006, The Taunton Press, Inc.

Middle Photograph: Steve Kuzma Photography and Studio Z Architecture

Bottom photograph: Grace Riggan

### Introduction/Green From the Start, pages viii–xv

Technical Illustrations: Steve Baczek, AIA

### Kitchen, pages 1–6

Photography: Jonathan Leys, WoodMaster  
Illustration: Julia Jandrisits

### Bathroom, pages 7–12

Photography: Debra Lynn Dadd

Illustration: Julia Jandrisits

Technical Illustrations: Steve Baczek

### Bedroom, pages 13–18

Page 13: Photograph by Steve Kuzma Photography and Studio Z Architecture

Page 16, Before photograph: Gina Smith

Page 16 and 17, Photography: Mary Cordaro

Illustration: Julia Jandrisits

### Living & Working, pages 19–24

Page 20: Photograph by Sean Groom,  
*Fine Homebuilding Magazine* © 2006,  
The Taunton Press, Inc.

Page 22 and 23, Photography: Pam Sowerby

Illustration: Julia Jandrisits

### Finished Basement, pages 25–30

Photography by Jimmy Carrion, Photographer and Architect for Hoots Group

Illustration: Julia Jandrisits

Technical Illustration: Steve Baczek

### Home Performance, pages 31–36

Page 31: Photograph by Mark Piepkorn,  
BuildingGreen, LLC

Page 35 and 36, Photography: Matt Golden,  
Sustainable Spaces Inc.

Illustration: Julia Jandrisits

Technical Illustrations: Steve Baczek

### Major Addition, pages 37–42

Photography by Steve Kuzma Photography and Studio Z Architecture

Page 41: Before photograph: Dawn Zuber,  
Studio Z Architecture

Illustration: Julia Jandrisits

Technical Illustration: Steve Baczek

### Gut Rehab, pages 43–48

Page 43: Photograph by Mark Piepkorn,  
BuildingGreen, LLC

Pages 46 and 47, Photography: Robert Politzer  
Illustration: Julia Jandrisits

### Deep Energy Retrofit, pages 49–54

Page 49: Photograph by Charles Miller,  
*Fine Homebuilding Magazine* © 2006,  
The Taunton Press, Inc.

Pages 53 and 54, Photography: Eric Doub,  
Ecofutures Building Inc.

Page 51: Technical Illustration: Steve Baczek

Page 52: Technical Illustration: Eric Doub,  
Ecofutures Building Inc.

### Outdoor Living, pages 55–60

Photography: Grace Riggan

Illustration: Julia Jandrisits

### Strategy Library and Image Appendix, pages 61–152

Technical Illustrations: Steve Baczek

Photography: Matt Golden, Carl Seville,

Peter Yost, Mark Piepkorn as well as

Kelly Bentham, Renovator's Resource, Inc.

### Building Profile Worksheet, page 163

3-D Building Solutions, LLC

The American Society of Interior Designers' Foundation and the U.S. Green Building Council have partnered on the development of best practice guidelines and targeted educational resources for sustainable residential improvement projects. This program will increase understanding of sustainable renovation project practices and benefits among homeowners, residents, design professionals, product suppliers and service providers to build both demand and industry capacity.

This program will complement the release of LEED for Homes, but is not itself a LEED-branded rating system with certification thresholds and recognition levels. It is a guideline with educational resources for setting and achieving performance-based objectives for sustainable residential improvement projects.

A technical committee comprised of both ASID and USGBC members and invited experts has developed these guidelines. The guidelines focus on the key practice areas and define performance-based objectives for sustainable residential renovation projects. The accompanying manual will outline detailed strategies for applying the guidelines and include illustrative case studies and resource references.

[www.regreenprogram.org](http://www.regreenprogram.org)

